

QUICKSCREEN, XPRESS PLUS & ALUMAWOOD slat screening systems

What you'll find inside

Quickscreen side frame systems

Xpress Plus post & side frame systems

Vertical slat systems

Alumawood side frame, pedestrian & sliding gate systems

Pedestrian & sliding gate systems

Gate hinges, latches & accessories

Posts, accessories & letterboxes

The essentials.

PAGE **4**

Quickscreen

PAGE **23**

Xpress Plus

PAGE **36**

Slat caps & topper

PAGE **41**

Alumawall

PAGE **42**

Xpress Plus Premium

PAGE **56**

Pedestrian gates

PAGE **72**

Gate hinges

PAGE **77**

Gate latches

PAGE **86**

Sliding gates

PAGE **100**

Alumawood

PAGE **152**

Equipment enclosure

PAGE **156**

Letterboxes

PAGE **164**

POSTA characters

Side frame systems 3 ranges available

QUICKSCREEN

Suits 65x16.5mm or 90x16.5mm slat
Horizontal or vertical slat installation
Screw fix off each slat
Snap on cover hides fixings
Allows variable slat spacing

XPRESS PLUS

Suits 65x16.5mm or 90x16.5mm slat
Horizontal slat installation
Patented non-weld friction fit
Allows variable slat spacing

XPRESS PLUS PREMIUM

Suits 65x16.5mm slat
Horizontal slat installation
Patented non-weld friction fit
9 or 20mm spacing
Aluminium punched insert provides premium finish

**ALL SYSTEMS AVAILABLE IN LONG LENGTH SUPPLY
OR CUSTOM CUT TO SIZE & FLAT PACKED**

QUICKSCREEN

EXTRUDED & POWDER COATED IN AUSTRALIA
HIGHEST QUALITY FINISHES —

Our range of genuine Interpon D1000 series powder coat finishes has been carefully selected to include the most sought after colours on offer.

All components are suitably pre-treated prior to powder coating and are applied by fully accredited coating facilities.



Note: Colours displayed are a guide only



The Quickscreen system is extremely cost effective. Each slat is screwed off once in position. The system allows for variable slat spacing so any gap is achievable. Once slats are screwed off, a snap on cover hides the fixings to provide a seamless finish.

For horizontal slat screening, generally the side frame is screwed directly to a post or wall without need of another U channel or angle.

In 'void' situations where slats cannot be fed in from top down, an F section is available. The F section can also be used where it is preferred to pre-make complete panels in a factory and simply install onsite.

For raking panels/angles, slats can be cut at an angle and screwed off making Quickscreen an ideal solution for difficult installations.

Available in long length supply or custom cut to size ready for assembly.

SYSTEM ADVANTAGES

Concealed fixing: screws are hidden – clean finish!



Low maintenance – unlike timber screening



Cost effective solution



Hinged & sliding gates also available









Adjustable slat spacing



QUICKSCREEN HORIZONTAL SLAT SYSTEM

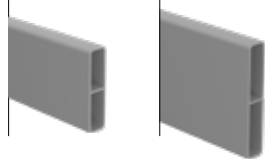

- 1 **Concealed fixing cover**
 QS-5800-CFC
 Refer page 8
 
- 2 **Side frame**
 QS-5800-SF
 Refer page 8
 
- 3 **Spacers & screws**
 QS-KIT
 Refer page 10
 
- 4 **Side frame top cap**
 QS-SFC-B
 Refer page 11
 
- 5 **65x16.5mm or 90x16mm slat**
 65mm: 6100mm or 6500mm long
 90mm: 6100mm long
 Refer page 7
 
- 6 **F section**
 QS-5800-F
 Refer page 8
 



POSTS & ACCESSORIES —

- 1 50x50mm post
- 4 Dress rings
- 2 65x65mm heavy duty post
- 5 Domical covers
- 3 Top caps
- 6 Base plates

For full range of posts & accessories, see pages 20 & 21

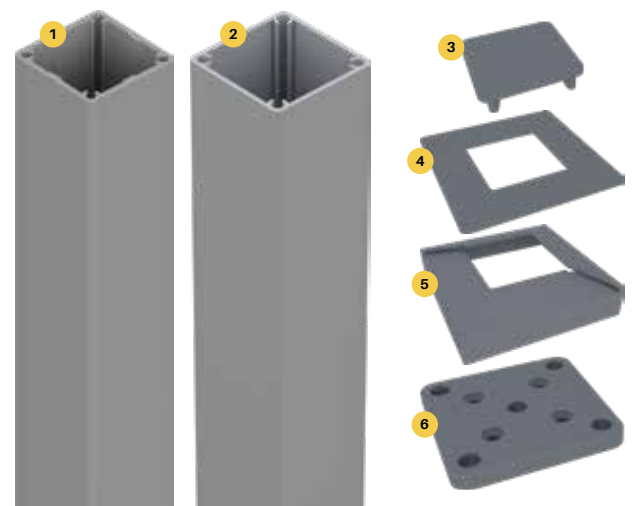

Fencing solution featuring
Quickscreen side frames,
50x50mm posts & horizontal slat



SLAT OPTIONS

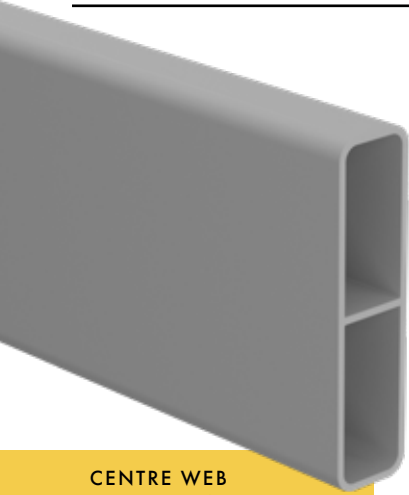

CENTRE WEB
ADDS STRENGTH &
RIGIDITY TO SLAT

65mm x 16.5mm slat with centre web

6100MM LONG

Order Code: XP-6100-S65

SOLD AS SINGLE LENGTHS,
BUNDLES OR PACK LOTS

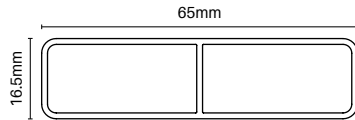

Finishes

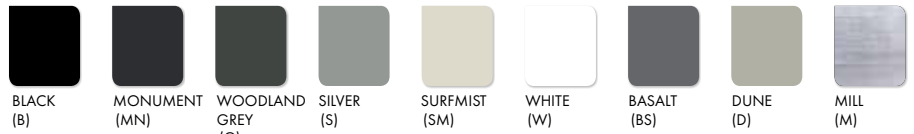

Primrose & Paperbark also available from Brisbane, Adelaide & Perth depots

TECH SPECS

- PP 157 / AP 157
- Alloy 6063-T6
- 6100mm long
- 1.2mm wall thickness with centre web
- 3.5mm radius corners
- Genuine Australian Interpon powder coat
- lxx = 9.60 x 10E3 mmE4
- lyy = 83.09 x 10E3 mmE4

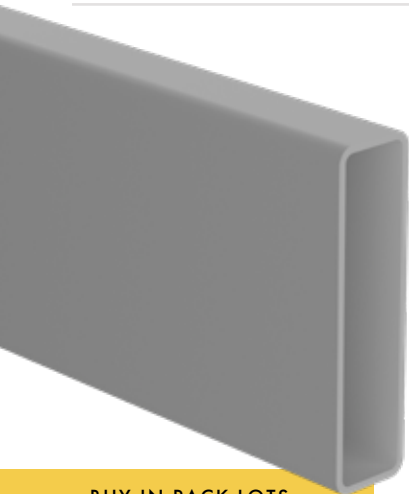
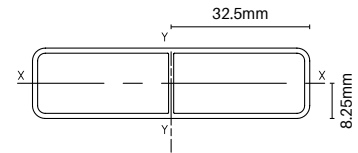

BUY IN PACK LOTS
FOR BEST PRICING!

65mm x 16.5mm slat

6500MM LONG

Order Code: XP-6500-E65

SOLD IN PACKS OF 96 ONLY
Not sold as single lengths

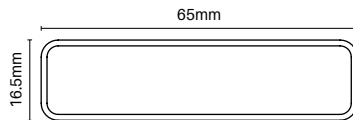

Finishes



TECH SPECS

- PP 157 / AP 157
- Alloy 6063-T6
- 6500mm long
- 1.2mm wall thickness
- 3.5mm radius corners
- Genuine Australian Interpon powder coat
- lxx = 9.31 x 10E3 mmE4
- lyy = 83.09 x 10E3 mmE4

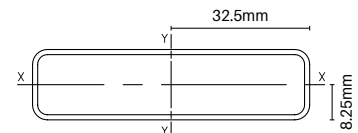

CENTRE WEB
ADDS STRENGTH &
RIGIDITY TO SLAT

90mm x 16.5mm slat with centre web

6100MM LONG

Order Code: QS-6100-S90

SOLD AS SINGLE LENGTHS,
BUNDLES OR PACK LOTS

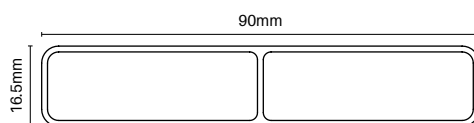

Finishes

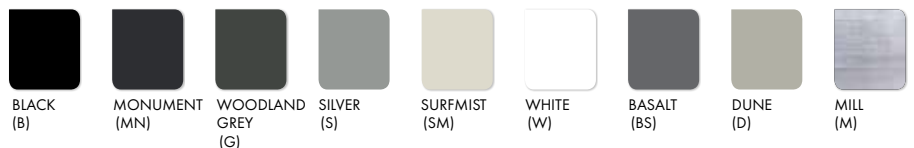

TECH SPECS

- PP 208 / AP 208
- Alloy 6063-T6
- 6100mm long
- 1.2mm wall thickness with centre web
- 3mm radius corners
- Genuine Australian Interpon powder coat
- lxx = 13.28 x 10E3 mmE4
- lyy = 202.57 x 10E3 mmE4

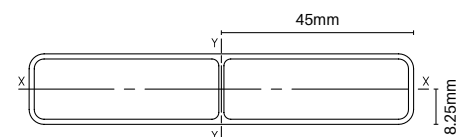

EXTRUSIONS



Side frame

5800MM LONG

Order Code: **QS-5800-SF**

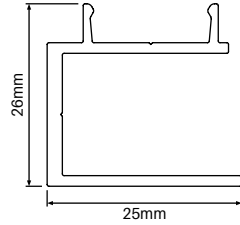

TECH SPECS

- PP 104 / AP 156
- Alloy 6063-T6 / 5800mm long
- Each slat must be screw fixed to side frame
- Affix side frame directly to post or wall or use with F-section
- Screw fixings are hidden when panel is assembled
- lxx = 9.58 x 10E3 mmE4
- lyy = 8.38 x 10E3 mmE4

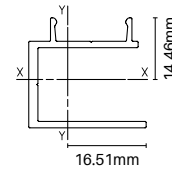

Finishes



Primrose & Paperbark also available from Brisbane, Adelaide & Perth depots

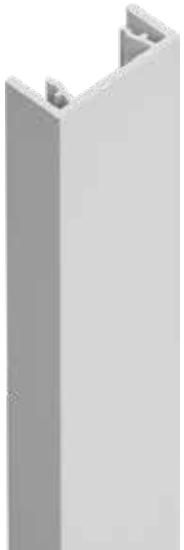

Concealed fixing cover

5800MM LONG

Order Code: **QS-5800-CFC**

MATES WITH QS-5800-SF

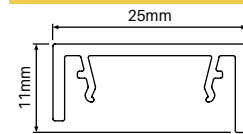

TECH SPECS

- PP 100 / AP 116
- Alloy 6060-T5 / 5800mm long
- Snap-on cover for side frame
- Hides screws used to affix slats to side frame
- lxx = 0.71 x 10E3 mmE4
- lyy = 6.58 x 10E3 mmE4

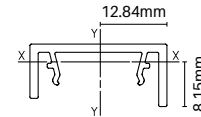

Finishes

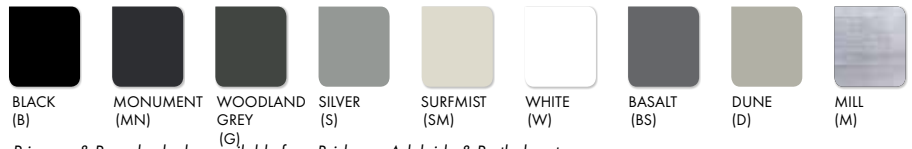

Primrose & Paperbark also available from Brisbane, Adelaide & Perth depots



F section

5800MM LONG

Order Code: **QS-5800-F**

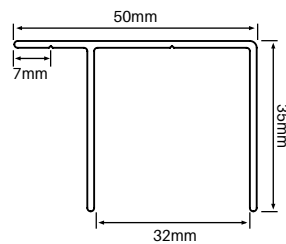

TECH SPECS

- PP 170 / AP 234
- Alloy 6063-T6
- 5800mm long
- Fix off to wall or post through 15mm offset leg
- Use in a void situation or if panels pre-assembled in factory for installation onsite
- 1.4mm wall thickness
- lxx = 20.76 x 10E3 mmE4
- lyy = 42.29 x 10E3 mmE4

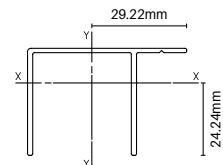

Finishes



Primrose & Paperbark also available from Brisbane, Adelaide & Perth depots

QUICKSCREEN 135 ANGLE ADAPTER

135 degree adapter

6000MM LONG
Order Code: XP-6000-135

TECH SPECS

- PP 109 / AP 163
- Alloy 6060 - T5
- Simple 2 step process:
 - (1) Adapter fixes to post/wall.
 - (2) Quickscreen side frame then attaches to adapter into which slats insert
- Ideal for when screens to run at 135 degree angle from post or wall
- lxx = 5.76 x 10E3 mmE4
- lyy = 25.92 x 10E3 mmE4

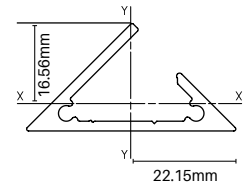
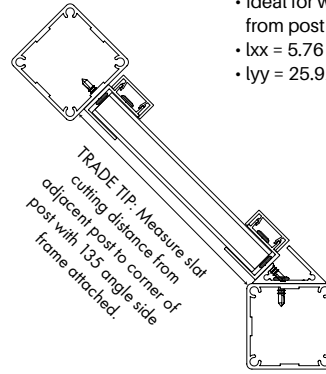
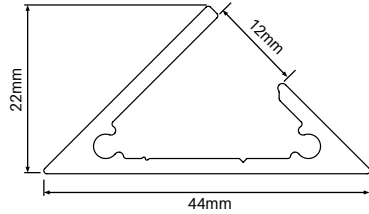

Finishes



Primrose & Paperbark also available from Brisbane, Adelaide & Perth depots

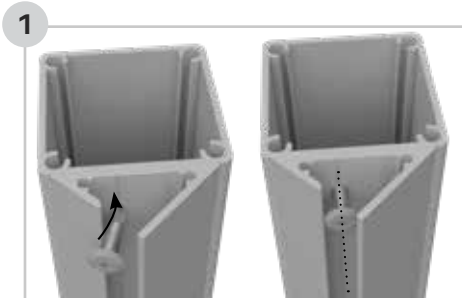

Place 135 adapter against post/wall. Insert screw into void opening. Screw fix adapter using V groove as a guide to fixing location.
TIP: pilot hole drill before screw fixing; max screw head size is 10mm.

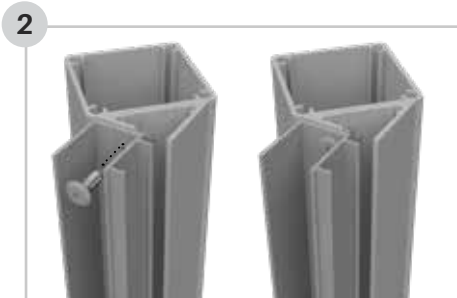

Screw fix Quickscreen Side Frame to 135 adapter fixing through adapter short leg.

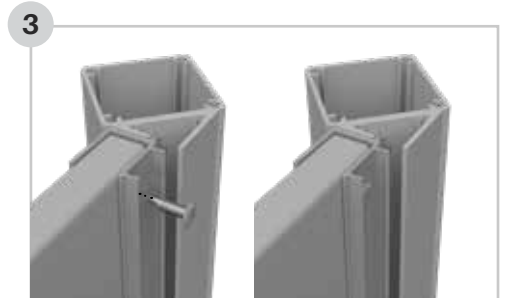

Insert slats into Quickscreen side frame and fix off slats.

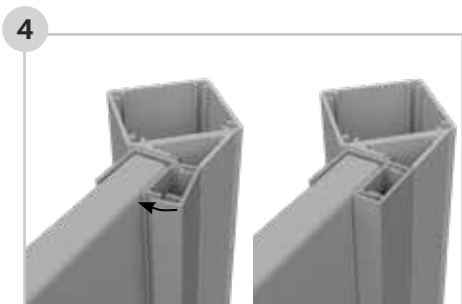

Snap on concealed fixing cover. Lever into place with short leg going on first then levering on long leg to snap into position.

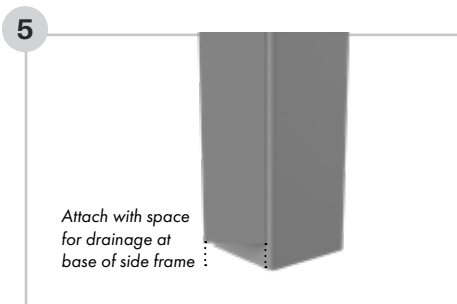

135 adapter should be cut so that it is elevated from floor and at the same length as Quickscreen Side Frame.

EXTRAS

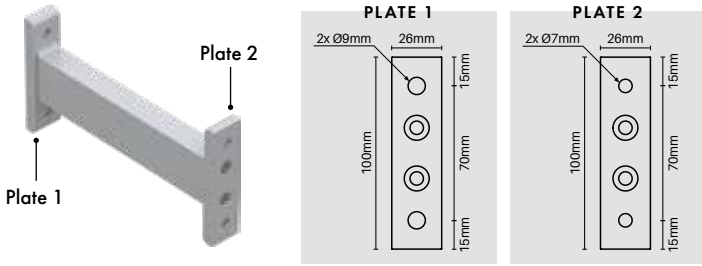

Side frame mounting arm

200MM or 400MM WIDE

Black / Monument / Woodland Grey

Silver / Surfmist / Mill finish

Order Code: XP-ARMSF (200mm W)

XP-ARMSF-400-M (400mm W – Mill finish)

- 2x welded fixing plates – 100mm L x 26mm W x 10mm D
- 2x Ø9mm fixing holes (plate 1) & 2x 7mm fixing holes (plate 2)

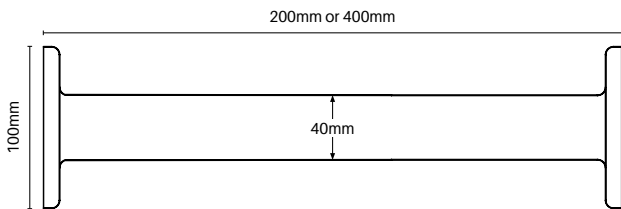

Louvre brackets

1x LEFT & 1x RIGHT

Black / Monument / Woodland Grey / Silver / Surfmist / White Basalt / Dune / Mill finish

Order Code: QS-LB

- 1x left and 1x right bracket per pack
- Die cast aluminium
- Suits 65x16.5mm slat – Press brackets onto end of slat then insert bracket into side frame
- Space brackets at nil, 5, 9, 20mm or any spacing desired
- Cost effective and fast way to achieve a fixed louvre finish

40° FINAL SLAT ANGLE

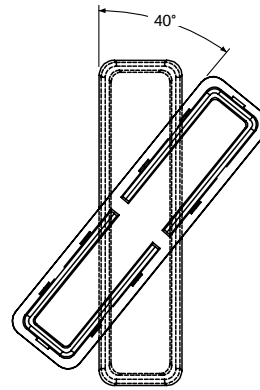

Self drilling wafer screws

10Gx16mm – BAG OF 100

Black / Monument / Woodland Grey /

Silver / Surfmist / White Basalt /

Dune / Mill finish

Order Code: XP-SCREWS

- Bags of 100 – 10G x 16mm self drilling wafer head zinc plated
- Powder coated heads for neat finish
- Ideal for fixing of side frames to U channel or F section



Touch up paint

150g SPRAY CAN

Black / Monument / Woodland Grey / Silver / Surfmist / White

Basalt / Dune

Order Code:

PAINT-B/G/MN/S/SM/W/BS/D

- Colour match touch up paint
- Simply spray on for minor touch ups



Screw & spacer kit

SCREWS & SPACER BLOCKS

Order Code: QS-KIT

- 50 screws: 10G x 18mm long
- 10x spacer blocks
- Spacers enable 9mm, 15mm or 20mm spacing between slats
- Use screws to fix off slats
- Once screws fixed off, spacers may be removed

EXTRUSIONS



Centre support rail

5800MM LONG

Order Code: **XP-5800-CSR**

OPTIONAL EXTRA

Commonly used for screens 2000mm or wider to provide strength & rigidity to panel

Snap-on cover hides fixings – provides slimline sturdy support rail with no visible fixings

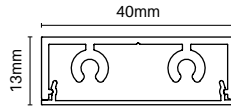

TECH SPECS

- PP 126 / AP 188
- Alloy 6063-T5
- 5800mm long
- Screw fix off to each slat to provide support/rigidity
- Support rail is installed vertically to brace horizontal slats
- Includes 2x screw flutes for cap insertion
- lxx = 1.73 x 10E3 mmE4
- lyy = 26.34 x 10E3 mmE4

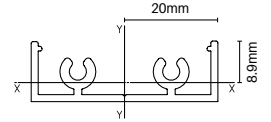

Finishes



Primrose & Paperbark also available from Brisbane, Adelaide & Perth depots

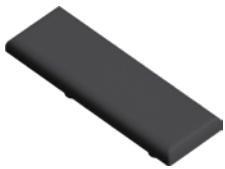

Centre support rail cap

40mm x 13mm

3 MM THICK

Order Code: **XP-CSRC-B**

- Black nylon cap
- Simply press into screw flutes in centre support rail
- Easy and fast fitting of cap

MATES WITH **QS-5800-CSR**

Finishes



Centre support rail top/bottom plate

Order Code: **XP-BTP-TR**

- Optional extra to install as part of centre support rail
- Aluminium with countersunk hole machining
- 2x CSK screws included for fixing to CSR
- Use to brace top and/or bottom of centre support rail to structure above or below if desired
- Bracing centre support rail provides extra rigidity to panels - recommended for wide screens

MATES WITH **XP-5800-CSR**



Screw top/bottom plate to centre support rail



Screw through central hole to substrate at top or bottom

Finishes



Primrose & Paperbark also available from Brisbane, Adelaide & Perth depots



Side frame top cap

30mm x 26mm

3 MM THICK

Order Code: **QS-SFC-B**

- Black nylon cap
- Simply press into side frame
- Easy and fast fitting of cap

MATES WITH **QS-5800-SF**
+
QS-5800-CFC

Finishes



BLACK (B)



QUICKSCREEN SYSTEM

Slat Qty	Slat spacing	Height	Slat Qty	Slat spacing	Height
5	Nil	328mm	23	Nil	1498mm
	5mm	348mm		5mm	1608mm
	9mm	364mm		9mm	1696mm
	20mm	408mm		20mm	1938mm
6	Nil	393mm	24	Nil	1563mm
	5mm	418mm		5mm	1678mm
	9mm	438mm		9mm	1770mm
	20mm	493mm		20mm	2023mm
7	Nil	458mm	25	Nil	1628mm
	5mm	488mm		5mm	1748mm
	9mm	512mm		9mm	1844mm
	20mm	578mm		20mm	2108mm
8	Nil	523mm	26	Nil	1693mm
	5mm	558mm		5mm	1818mm
	9mm	586mm		9mm	1918mm
	20mm	663mm		20mm	2193mm
9	Nil	588mm	27	Nil	1758mm
	5mm	628mm		5mm	1888mm
	9mm	660mm		9mm	1992mm
	20mm	748mm		20mm	2278mm
10	Nil	653mm	28	Nil	1823mm
	5mm	698mm		5mm	1958mm
	9mm	734mm		9mm	2066mm
	20mm	833mm		20mm	2363mm
11	Nil	718mm	29	Nil	1888mm
	5mm	768mm		5mm	2028mm
	9mm	808mm		9mm	2140mm
	20mm	918mm		20mm	2448mm
12	Nil	783mm	30	Nil	1953mm
	5mm	838mm		5mm	2098mm
	9mm	882mm		9mm	2214mm
	20mm	1003mm		20mm	2533mm
13	Nil	848mm	31	Nil	2018mm
	5mm	908mm		5mm	2168mm
	9mm	956mm		9mm	2288mm
	20mm	1088mm		20mm	2618mm
14	Nil	913mm	32	Nil	2083mm
	5mm	978mm		5mm	2238mm
	9mm	1030mm		9mm	2362mm
	20mm	1173mm		20mm	2703mm
15	Nil	978mm	33	Nil	2148mm
	5mm	1048mm		5mm	2308mm
	9mm	1104mm		9mm	2436mm
	20mm	1258mm		20mm	2788mm
16	Nil	1043mm	34	Nil	2213mm
	5mm	1118mm		5mm	2378mm
	9mm	1178mm		9mm	2510mm
	20mm	1343mm		20mm	2873mm
17	Nil	1108mm	35	Nil	2278mm
	5mm	1188mm		5mm	2448mm
	9mm	1252mm		9mm	2584mm
	20mm	1428mm		20mm	2958mm
18	Nil	1173mm	36	Nil	2343mm
	5mm	1258mm		5mm	2518mm
	9mm	1326mm		9mm	2658mm
	20mm	1513mm		20mm	3043mm
19	Nil	1238mm	37	Nil	2408mm
	5mm	1328mm		5mm	2588mm
	9mm	1400mm		9mm	2732mm
	20mm	1598mm		20mm	3128mm
20	Nil	1303mm	38	Nil	2473mm
	5mm	1398mm		5mm	2658mm
	9mm	1474mm		9mm	2806mm
	20mm	1683mm		20mm	3213mm
21	Nil	1368mm	39	Nil	2538mm
	5mm	1468mm		5mm	2728mm
	9mm	1548mm		9mm	2880mm
	20mm	1768mm		20mm	3298mm
22	Nil	1433mm	40	Nil	2603mm
	5mm	1538mm		5mm	2798mm
	9mm	1622mm		9mm	2954mm
	20mm	1853mm		20mm	3383mm

65mm slat spacing table

HORIZONTAL SLAT SYSTEM

Slat Qty

Total number of slats required for height shown in corresponding rows

Slat spacing

Height of gap between each slat

Height

The Quickscreen side frames allow for variable gap spacing as each slat is fixed off at desired position. Any gap is achievable. Shown are specifications for the popular spacings of nil, 5mm, 9mm & 20mm spacing.

The formula to calculate variable gap screen height is:
 $((65\text{mm (slat height)} + \text{desired gap}) \times \text{number of slats}) - \text{desired gap} + 3\text{mm}$
 (for top cap).

For example, a 30mm desired gap with 14 slats: $(65 + 30) \times 14 - 30 + 3 = 1303\text{mm}$ high

QUICKSCREEN SYSTEM



90mm slat spacing table

HORIZONTAL SLAT SYSTEM

Slat Qty

Total number of slats required for height shown in corresponding rows

Slat spacing

Height of gap between each slat

Height

The Quickscreen side frames allow for variable gap spacing as each slat is fixed off at desired position. Any gap is achievable. Shown are specifications for the popular spacings of nil, 5mm, 9mm & 20mm spacing.

The formula to calculate variable gap screen height is:

$((90\text{mm (slat height)} + \text{desired gap}) \times \text{number of slats}) - \text{desired gap} + 3\text{mm}$ (for top cap).

For example, a 30mm desired gap with 14 slats: $(90 + 30) \times 14 - 30 + 3 = 1653\text{mm}$ high

Slat Qty	Slat spacing	Height
5	Nil	453
	5mm	473
	9mm	489
	20mm	533
6	Nil	543
	5mm	568
	9mm	588
	20mm	643
7	Nil	633
	5mm	663
	9mm	687
	20mm	753
8	Nil	723
	5mm	758
	9mm	786
	20mm	863
9	Nil	813
	5mm	853
	9mm	885
	20mm	973
10	Nil	903
	5mm	948
	9mm	984
	20mm	1083
11	Nil	993
	5mm	1043
	9mm	1083
	20mm	1193
12	Nil	1083
	5mm	1138
	9mm	1182
	20mm	1303
13	Nil	1173
	5mm	1233
	9mm	1281
	20mm	1413
14	Nil	1263
	5mm	1328
	9mm	1380
	20mm	1523
15	Nil	1353
	5mm	1423
	9mm	1479
	20mm	1633
16	Nil	1443
	5mm	1518
	9mm	1578
	20mm	1743
17	Nil	1533
	5mm	1613
	9mm	1677
	20mm	1853
18	Nil	1623
	5mm	1708
	9mm	1776
	20mm	1963
19	Nil	1713
	5mm	1803
	9mm	1875
	20mm	2073
20	Nil	1803
	5mm	1898
	9mm	1974
	20mm	2183
21	Nil	1893
	5mm	1993
	9mm	2073
	20mm	2293
22	Nil	1983
	5mm	2088
	9mm	2172
	20mm	2403

Slat Qty	Slat spacing	Height
23	Nil	2073
	5mm	2183
	9mm	2271
	20mm	2513
24	Nil	2163
	5mm	2278
	9mm	2370
	20mm	2623
25	Nil	2253
	5mm	2373
	9mm	2469
	20mm	2733
26	Nil	2343
	5mm	2468
	9mm	2568
	20mm	2843
27	Nil	2433
	5mm	2563
	9mm	2667
	20mm	2953
28	Nil	2523
	5mm	2658
	9mm	2766
	20mm	3063
29	Nil	2613
	5mm	2753
	9mm	2865
	20mm	3173
30	Nil	2703
	5mm	2848
	9mm	2964
	20mm	3283
31	Nil	2793
	5mm	2943
	9mm	3063
	20mm	3393
32	Nil	2883
	5mm	3038
	9mm	3162
	20mm	3503
33	Nil	2973
	5mm	3133
	9mm	3261
	20mm	3613
34	Nil	3063
	5mm	3228
	9mm	3360
	20mm	3723
35	Nil	3153
	5mm	3323
	9mm	3459
	20mm	3833
36	Nil	3243
	5mm	3418
	9mm	3558
	20mm	3943
37	Nil	3333
	5mm	3513
	9mm	3657
	20mm	4053
38	Nil	3423
	5mm	3608
	9mm	3756
	20mm	4163
39	Nil	3513
	5mm	3703
	9mm	3855
	20mm	4273
40	Nil	3603
	5mm	3798
	9mm	3954
	20mm	4383

HORIZONTAL SLAT INSTALL GUIDE

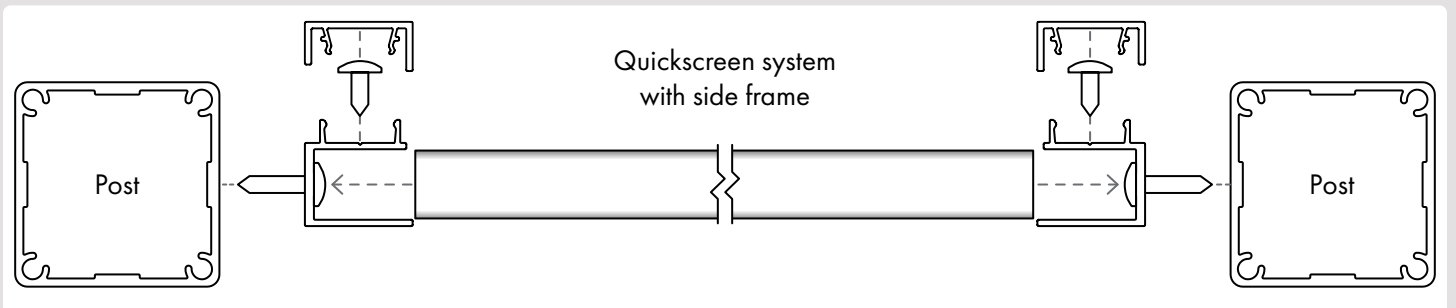
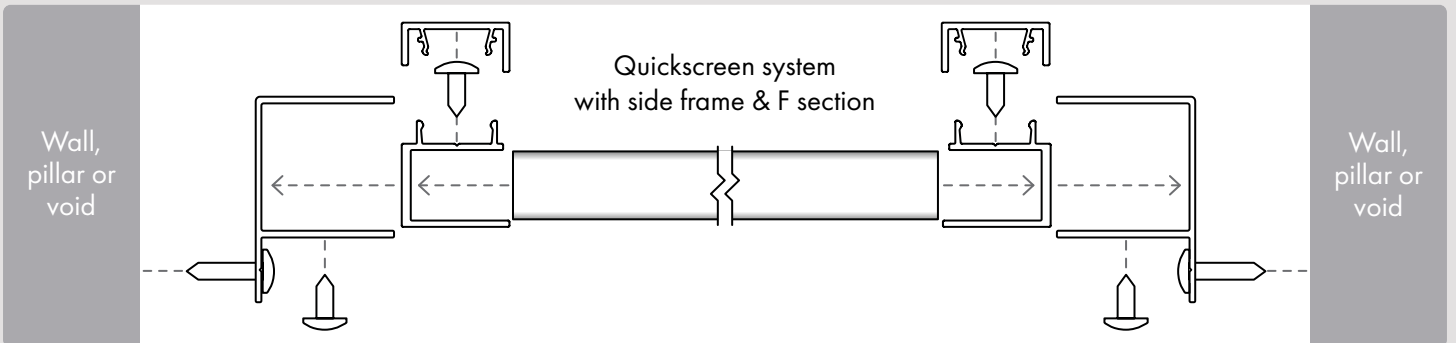
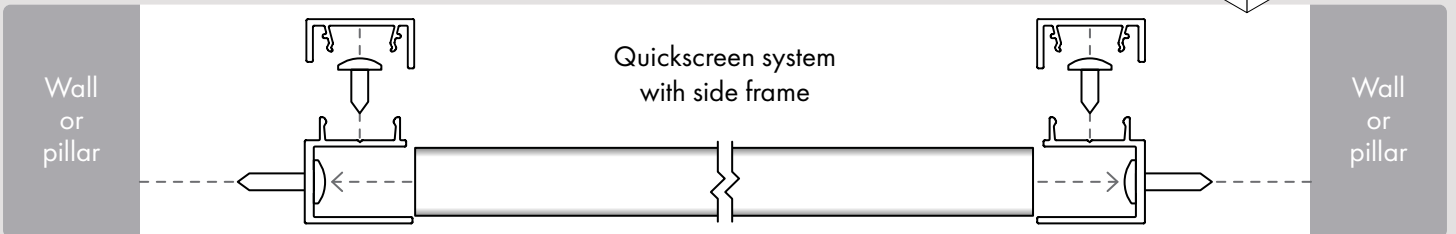
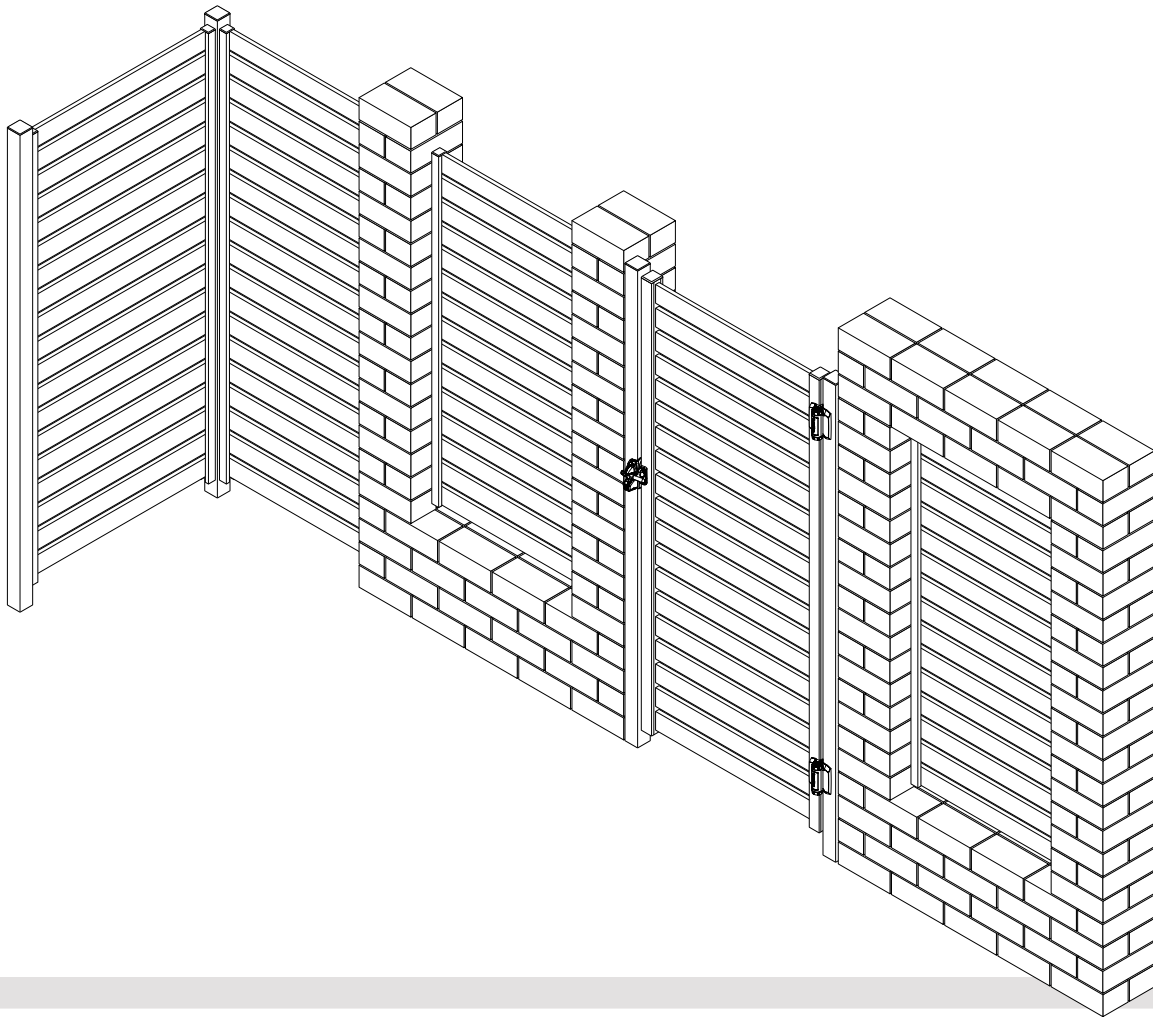

HORIZONTAL SLAT INSTALL GUIDE

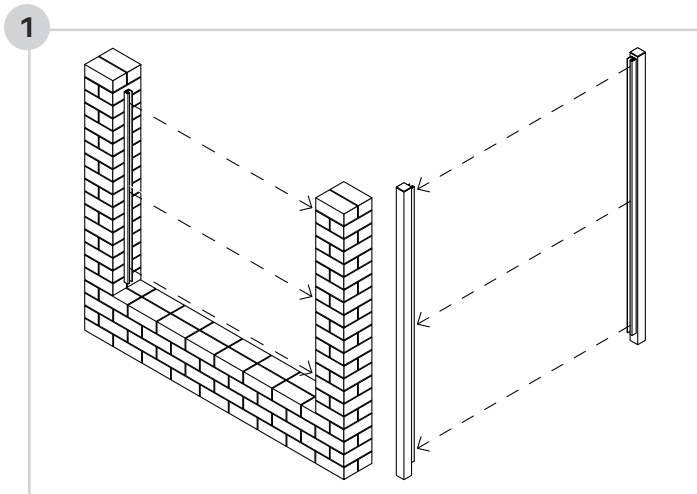

1 Take measurement between walls or posts at 3 points: top, middle and bottom (Take note of the smallest measurement)

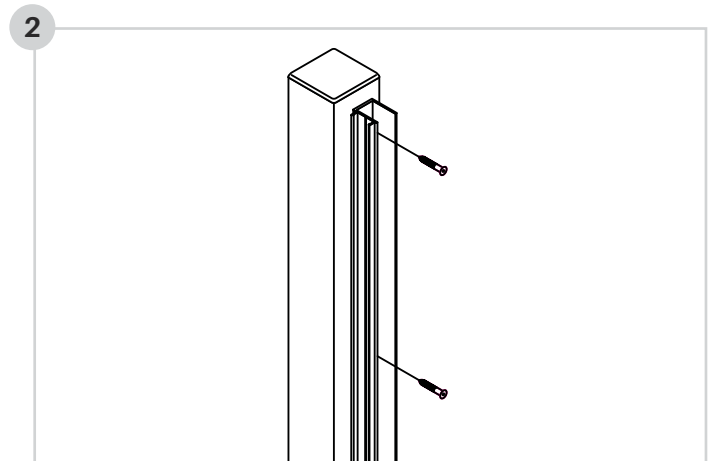

2 Cut side frames 3mm less than desired height (3mm allows for the top cap)
Affix side frames to wall or post with appropriate fixings

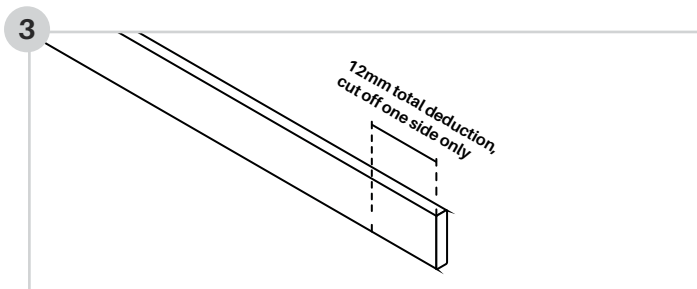

3 Cut aluminium slats 12mm less than total width of opening (Refer to measurement in step 1)

The 12mm deduction takes into account thickness of side frame on both sides of the screen and head of fixings.

Ensure fixings holding side frame do not obstruct slats when dropping in. If so, you may need to trim slats further.

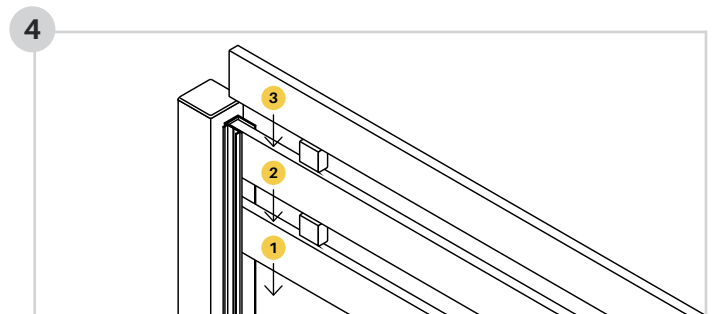

4 Drop in aluminium slats

Tip: Ensure bottom slat is level and screw off at both sides

Optional spacer blocks can be rotated to achieve a 9, 15 or 20mm slat gap. Any gap can be achieved by leaving a desired space. Consider using timber block spacers to achieve other gaps.

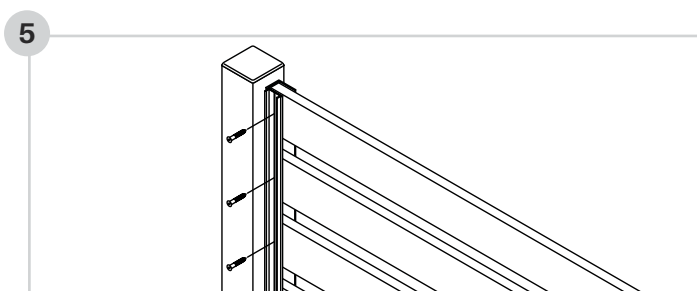

5 Screw off each slat as it is dropped in (ensuring each slat is level)
If spacer blocks used, remove after each level is installed.

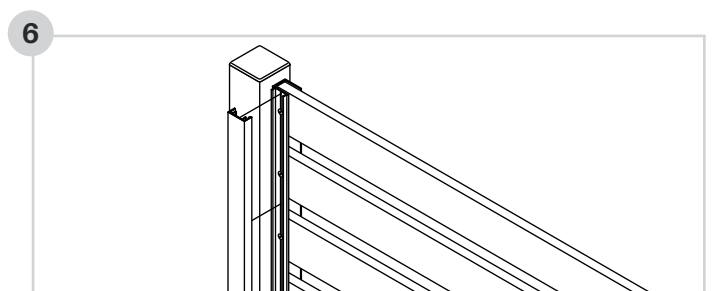

6 Cut snap on fixing cover to appropriate height

Attach snap on fixing cover to hide screws

Tip: If screen is wider than 1800mm, it is recommended to attach the centre support rail vertically at the centre of the screen. Cut centre support rail to appropriate height of screen and screw off to each slat at back side of screen

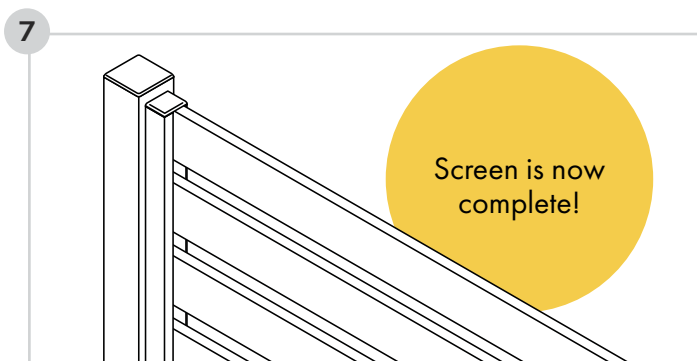

Snap on fixing cover install tip

Engage shorter leg of snap-on cover first.

At this point, the snap-on cover will be sitting off the side frame on an angle.

The longer leg must be at open side of side frame.

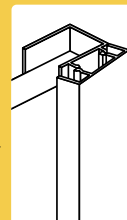

Starting from the top and working your way down, use a wood block and a hammer/mallet to tap the longer leg into place.

A short, sharp tap may be required to engage the long leg.

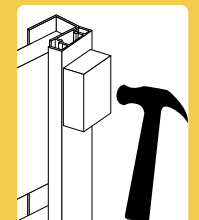

VERTICAL SLAT SYSTEM

Vertical slat is a stylish screening solution that continues to increase in popularity. The Quickscreen System allows 65x16.5mm or 90x16.5mm slats to be installed using a cost effective top/bottom rail system. Each slat requires screwing off at top and bottom. Screws are hidden by a heavy duty "U" section at top and bottom. An "F" section is installed vertically on both sides which allows easy installation between posts or pillars. A complete system is available – panels, pedestrian gates and sliding gates.

Ideal for installations between pillars and existing posts!

Available long length supply or custom made to size & flat packed.

ASSEMBLE ON-SITE OR IN YOUR WORKSHOP –

Panels fit into F section on both sides for easy installation. Problems with out of square pillars or posts can be easily overcome with F section fitting.



- 1 F section
- 2 U channel top/bottom rail
- 3 Quickscreen frame
- 4 65mm x 16.5mm slats (90mm x 16.5mm slats also available)

SLAT OPTIONS –

For full slat specification, see page 7

- 1 65x16.5mm slat with centre web
- 2 65x16.5mm econo slat
- 3 90x16.5mm slat with centre web

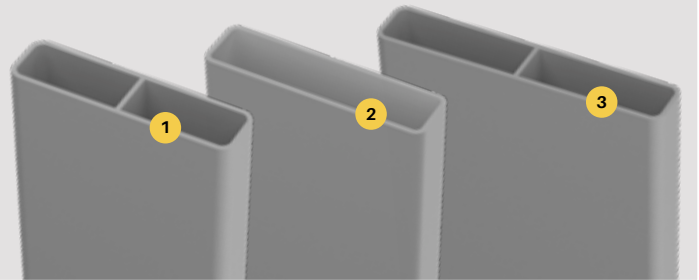

POSTS & ACCESSORIES –

- 1 50x50mm post
- 2 65x65mm heavy duty post
- 3 Top caps
- 4 Dress rings
- 5 Domical covers
- 6 Base plates

For full range of posts & accessories, see pages 20 & 21

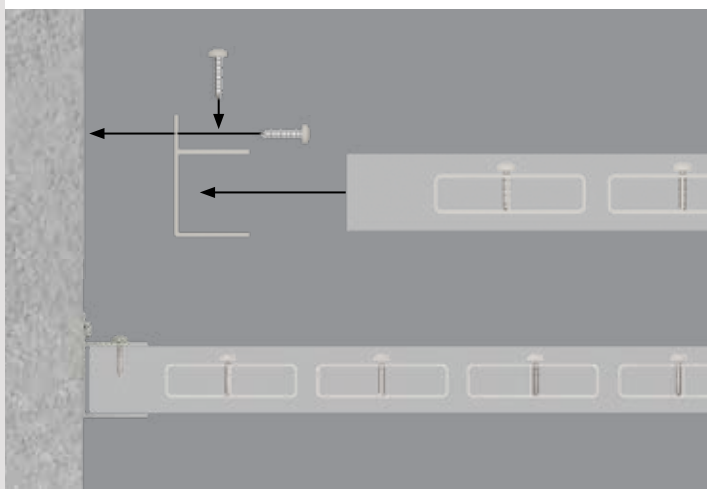
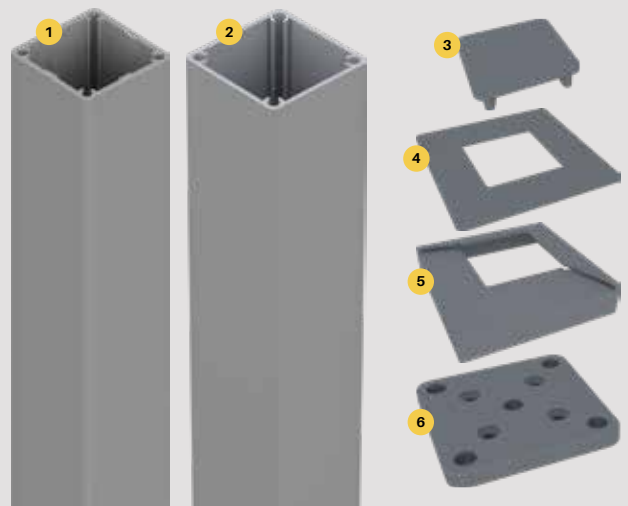

Quick and easy cut to size quoting & ordering process

Get instant pricing with our easy to use excel order form
2 ways to purchase – choose between cut to size or long length supply



VERTICAL SLAT COMPONENTS



Quickscreen frame

5800MM LONG

Order Code: QS-5800-SF

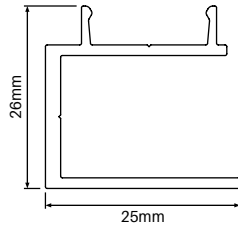

TECH SPECS

- PP 104 / AP 156
- Alloy 6063-T6 / 5800mm long
- Used as horizontal top & bottom rail
- Each slat must be screw fixed to frame
- Screw fixings are hidden when panel is assembled
- lxx = 9.58 x 10E3 mmE4
- lyy = 8.38 x 10E3 mmE4

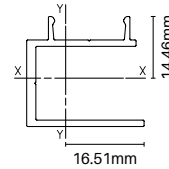

Finishes

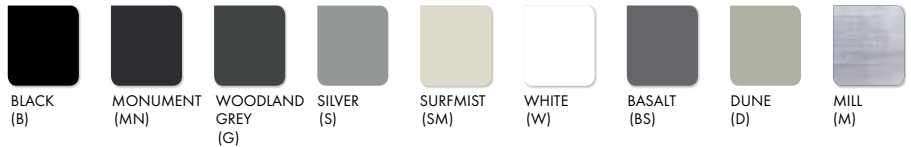

Heavy duty U channel top/bottom frame

5000MM LONG

Order Code: QS-5000-HORIZ

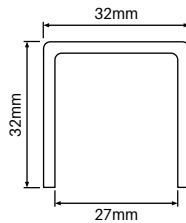

TECH SPECS

- PP 184 / AP 184
- Alloy 6060-T5
- Quickscreen frame fits neatly inside heavy duty U channel
- 5000mm long
- 2.5mm wall thickness
- lxx = 23.97 x 10E3 mmE4
- lyy = 38.92 x 10E3 mmE4

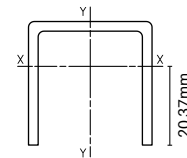

Finishes



Quickscreen F section

5800MM LONG

Order Code: QS-5800-F

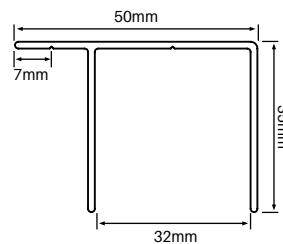

TECH SPECS

- PP 170 / AP 234
- Alloy 6063-T6
- 5800mm long
- Installed vertically at each side of screen into which heavy duty U channel placed horizontally
- 1.4mm wall thickness
- lxx = 20.76 x 10E3 mmE4
- lyy = 42.29 x 10E3 mmE4

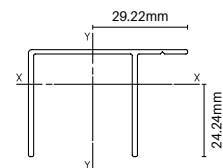

Finishes



ACCESSORIES



100mm support foot

HEIGHT ADJUSTABLE
SS316 / POLISH FINISH

Order Code: XP-FOOT-ADJ

- Height adjustable support foot for wider or larger screens
- Screw fix to midpoint of underside of bottom rail U channel
- Easily height adjustable (from 25mm up to 100mm) - stainless steel stem can be cut down and bottom flange reattached with grub screw

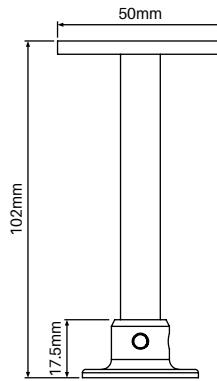

Remove stem from base plate and cut to required length



Quickscreen kit

SCREWS & SPACER BLOCKS

Order Code: QS-KIT

- 50x 10G x 18mm screws
- 10 x spacer blocks
- Spacers enable 9mm, 15mm or 20mm spacing between slats
- Remove spacer blocks once slats screwed off



Self drilling wafer screws

10Gx16mm – BAG OF 100

Black / Monument / Woodland Grey
Silver / Surfmist / White / Basalt

Dune / Mill finish

Order Code: XP-SCREWS

- Bags of 100 - 10G x 16mm self drilling wafer head zinc plated
- Powder coated heads for neat finish
- Ideal for fixing top/bottom frame to F section
- Can also be used for fixing slats to top/bottom frame



Touch up paint

150g SPRAY CAN

Black / Monument / Woodland Grey
Silver / Surfmist / White / Basalt / Dune

Order Code:

PAINT-B/G/MN/S/SM/W/BS/D

- Colour match touch up paint
- Simply spray on for minor touch ups



VERTICAL SLAT INSTALL GUIDE

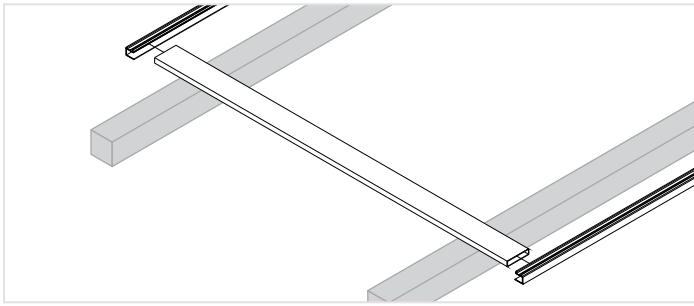

- 1 Place first slat on padded bearers, then place the top and bottom frames onto the slat.

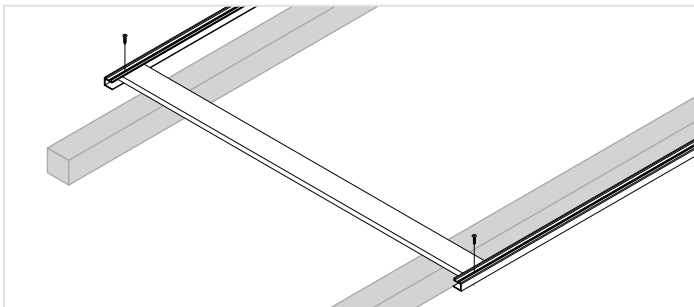

- 2 Position front edge of slat required distance from the edge of the top and bottom frame and screw through frame to affix at both end of the slat with 1x screw per end.

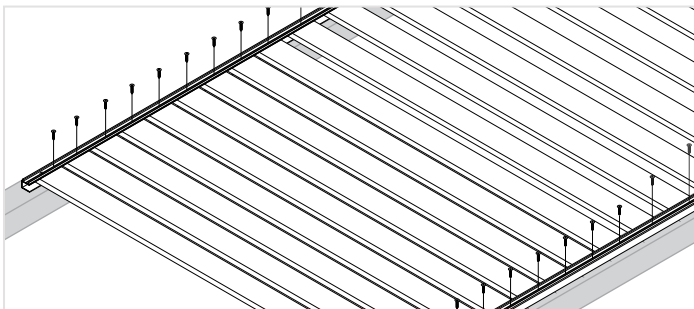

- 3 Slide remaining slats into the top and bottom frame and attach with single screw through top and bottom frames to affix, then check measure diagonals. Double screw fix first and last slats. **Keep slat spacing in mind!**

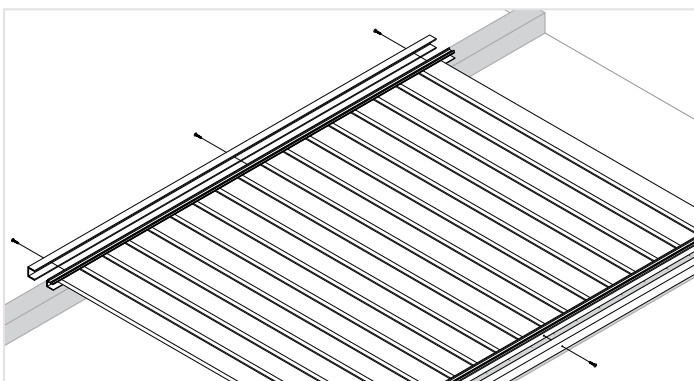

- 4 Place U channel over top and bottom frame, pre-drill 3mm holes and screw off in three points on top and bottom of the U channel – Measure in 50mm from the left and right edges, then one in the centre. **Ensure sufficient pilot holes are drilled before affixing, making sure they won't hit other screws.**



For panels over 1800mm wide, we suggest using a height adjustable foot underneath screen to prevent sagging of panel. Pre-drill 3mm holes and affix with screws. If using the height adjustable foot there is no need for a screw in the middle of the bottom rail.

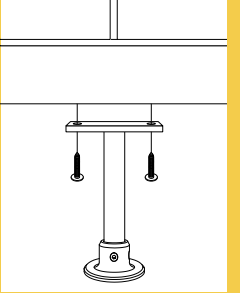

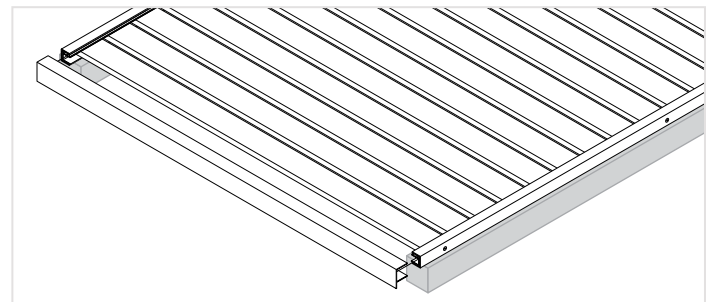

- 5 Place F section over each side of panel – F section will stay in place without screws until the last step.

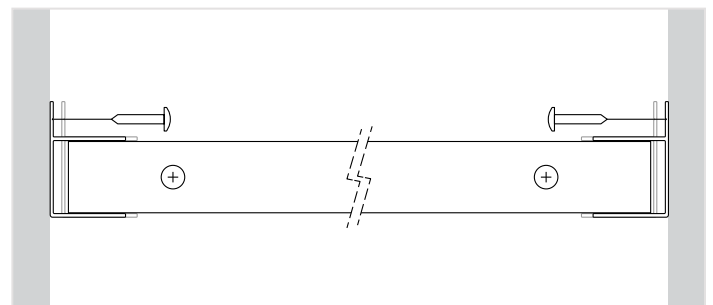

- 6 Lift panel into opening and push F section out to sit flush to wall then affix F section to wall (fixings not included). **Ensure sufficient pilot holes are drilled before affixing.**

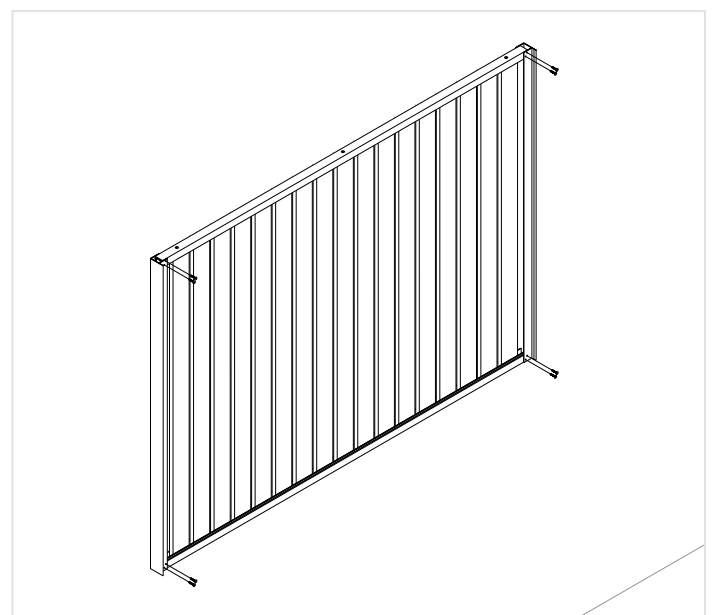

- 6 Affix panel to F section by pre-drilling 3mm holes and screwing through F section in corner positions – we suggest using 2 screws in each corner

POSTS & ACCESSORIES

APPLICABLE TO XPRESS PLUS, QUICKSCREEN SIDE FRAME & VERTICAL SLAT SYSTEMS



50x50mm full post

2400MM or 6000MM LONG

Order Code: XP-2400/6000-FP

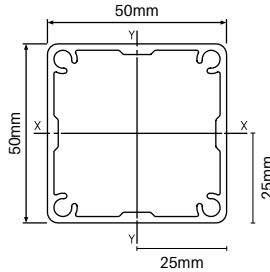

Finishes



TECH SPECS

- Alloy 6063 - T6
- 1.8mm wall thickness with 3mm ribs
- Screw flutes to screw on base plate if required
- Aluminium powder coated press-in top plate included with 2400mm posts
- lxx = 170.44 x 10E3 mmE4
- lyy = 170.44 x 10E3 mmE4

4x screw flutes in post allow tight fit of press in flat aluminium top plate.

Optional base plate can be attached using screw flutes for base plated post installations.



65x65mm heavy duty post

2400MM or 6000MM LONG

Order Code: XP-2400/6000-65HD

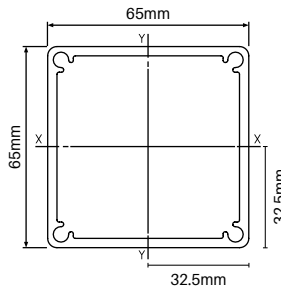

Finishes



TECH SPECS

- 65x65mm larger profile, heavy duty post
- Alloy 6063 - T6
- 3mm wall thickness
- Screw flutes to screw on base plate if required
- Aluminium powder coated press-in top plate included with 2400mm posts
- lxx = 464.62 x 10E3 mmE4
- lyy = 464.62 x 10E3 mmE4

4x screw flutes in post allow tight fit of press in flat aluminium top plate.

Optional base plate can be attached using screw flutes for base plated post installations.



50x50mm post flat top plate

POWDER COATED ALUMINIUM

Black / Monument / Woodland Grey / Silver
Surfmist White / Basalt / Dune / Mill finish

Order Code: XP-TP

- Alloy ADC12 aluminium plate
- Press into post screw flutes for secure fixing
- 2400mm posts come with free top plate included - only purchase if extra top plates are required
- Top plates required for 6000mm posts - sold separately



65x65mm post flat top plate

POWDER COATED ALUMINIUM

Black / Monument / Woodland Grey / Silver
Surfmist White / Basalt / Dune / Mill finish

Order Code: XP-65TP

- Alloy ADC12 aluminium plate
- Press into post screw flutes for secure fixing
- 2400mm posts come with free top plate included - only purchase if extra top plates are required
- Top plates required for 6000mm posts - sold separately

POSTS & ACCESSORIES

APPLICABLE TO XPRESS PLUS, QUICKSCREEN SIDE FRAME & VERTICAL SLAT SYSTEMS

SUITS 50x50MM POSTS

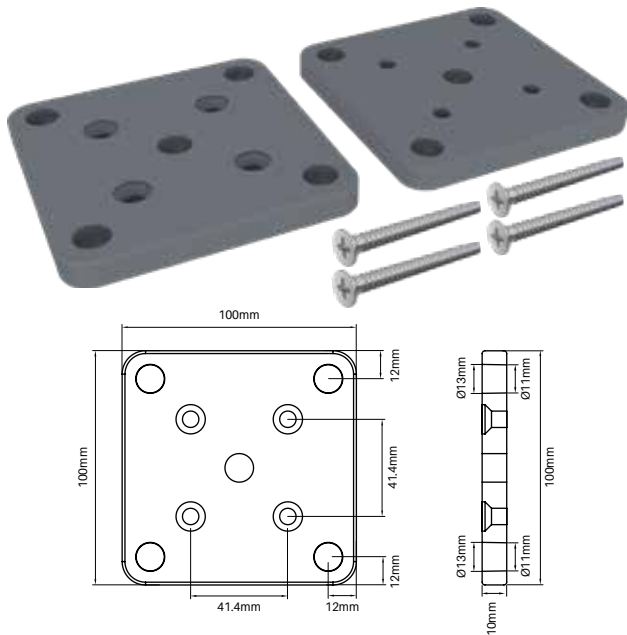

50x50mm post base plate set

POWDER COATED ALUMINIUM
Black / Monument / Woodland Grey
Silver / Surfmist / White / Basalt
Dune / Mill finish

Order Code: XP-BP-SET

- Simply screw base plate onto core drill post
- 4x 12G x 50mm long CSK screws included in set

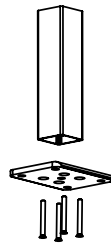

Powder coat colours



SUITS 65x65MM POSTS

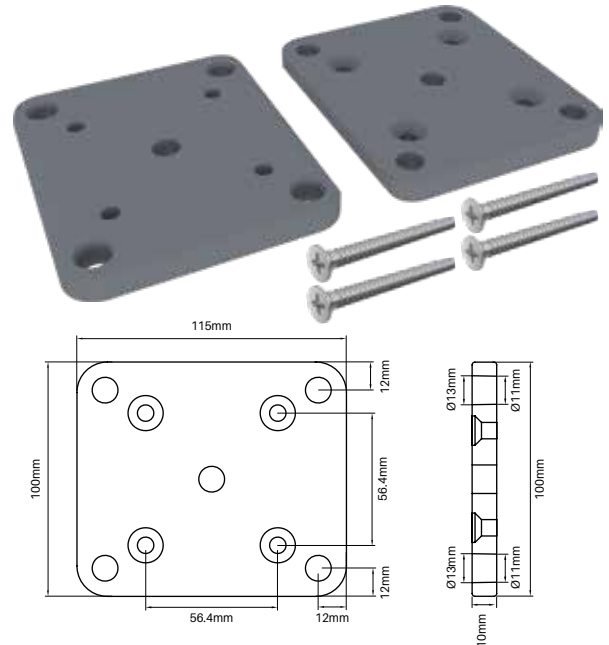

65x65mm post base plate set

POWDER COATED ALUMINIUM
Black / Monument / Woodland Grey
Silver / Surfmist / White / Basalt
Dune / Mill finish

Order Code: XP-65BP-SET

- Simply screw base plate onto core drill post
- 4x 12G x 50mm long CSK screws included in set

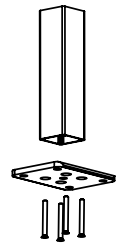

Powder coat colours

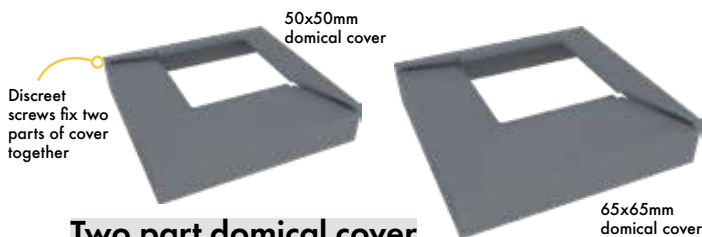

Two part domical cover

POWDER COATED ALUMINIUM
Black / Monument / Woodland Grey / Silver
Surfmist / White / Basalt / Dune / Mill finish

Order Code: XP-DC-2P (suits 50mm post)

XP-65DC-2P (suits 65mm post)

50mm domical cover:

- Suits 50x50mm post with screw fixed base plate
- 106x106mm outer - 52x52mm inner - Alloy ADC12
- Cover can be fitted to posts after fence is installed

65mm domical cover:

- Suits 65x65mm post with screw fixed base plate
- 122x106mm outer - 67x67mm inner - Alloy ADC12
- Cover can be fitted to posts after fence is installed

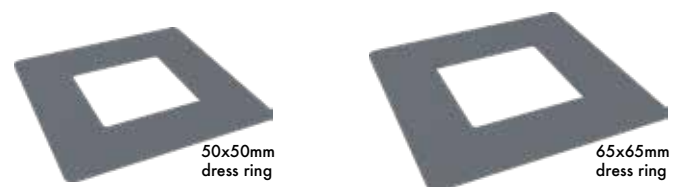

Post dress rings

POWDER COATED ALUMINIUM
Black / Monument / Woodland Grey / Silver
Surfmist / White / Basalt / Dune / Mill finish

Order Code: XP-DR (suits 50mm post)

XP-65DR (suits 65mm post)

50mm dress rings:

- Suits 50x50mm core drill posts
- 100mm x 100mm outer - 52mm x 52mm inner

65mm dress rings:

- Suits 65x65mm heavy duty post
- 115mm x 115mm outer - 67mm x 67mm inner





xpress plus

SIDE FRAME SYSTEM OVERVIEW

**Australia's leading
slat screen system**

**Designed & patented
Exclusive to GO & AO**

**Save time
& money**

Xpress Plus side frames feature patented internal legs designed to hold slats firmly in place. This innovative design feature allows assembly of pre-powder coated aluminium and does not require welding, screwing or riveting off each slat.

Ideal for installations between pillars and existing posts!

Horizontal slat screening system

TWO ASSEMBLY METHODS —

1. Build as you go: Affix side frames to post or wall and install slats working from the bottom to the top. No U channel or F section required.

2. Pre-assemble: Assemble panel in workshop or onsite. Install assembled panel using U channel or F section.

HIGHEST QUALITY WITH 10 YEAR WARRANTY —

Industry leading trade quality system. Extruded and powder coated in Australia. Genuine Interpon powder with 10 year Warranty. Large range of pre-powder coated stock available.

QUICK & EASY INSTALLATION —

Enjoy the benefits of our patented system allowing for assembly without need of welding, screwing or riveting off each slat.

COMPLETE SYSTEM —

Xpress Plus is a complete system consisting of slats, side frames, caps, posts, pedestrian gates and sliding gates. Highest quality product at the best trade prices.

VARIABLE SLAT SPACING —

Achieve any slat spacing desired. Slats are separated with slimline spacers that snap into the side frame. Stocked spacers are 5mm, 9mm and 20mm. 100mm lengths also available for cutting to required gap.

A premium aluminium insert with 9mm or 20mm spacing is also available to suit 65mm x 16.5mm slat.

THREE SLAT OPTIONS —

Choose from our range of 65mm x 16.5mm slats with or without centre web or 90mm x 16.5mm slats in stock to suit side frames.

EXTRUDED & POWDER COATED IN AUSTRALIA HIGHEST QUALITY FINISHES —

Our range of genuine Interpon D1000 series powder coat finishes has been carefully selected to include the most sought after colours on offer.

All components are suitably pre-treated prior to powder coating and are applied by fully accredited coating facilities.

B Black SATIN GN150A	MN Monument MATT GL229A	G Woodland Grey MATT GL205A
S Palladium Silver PEARL GY184C	SM Surfmist MATT GA236A	W Pearl White GLOSS GA078A
BS Basalt SATIN GP108A	D Dune SATIN GP152A	M Mill

SIDE FRAME INSTALLATION OPTIONS

Enjoy the flexibility of installing Xpress Plus patented side frames via two convenient methods

METHOD 1

BUILD AS YOU GO —

Pre-powder coated Xpress Plus side frames are affixed to a wall or pillar. Slats are then inserted from the bottom working upwards to completion. Slats are separated by snap in spacers. No U channel or F section required.

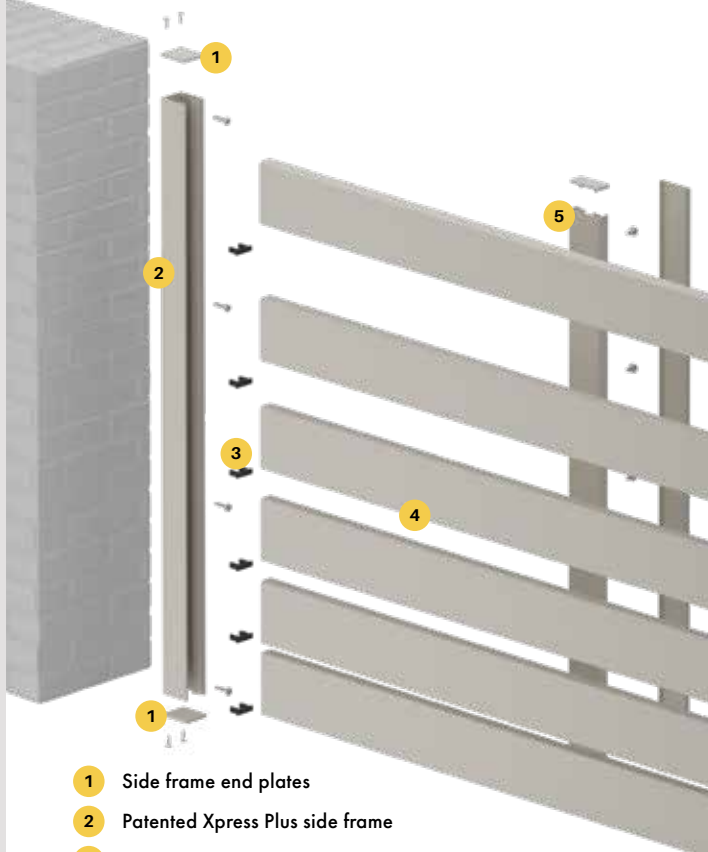

- 1 Side frame end plates
- 2 Patented Xpress Plus side frame
- 3 Snap-in spacers
- 4 65mm x 16.5mm slats (90mm x 16.5mm slats also available)
- 5 Centre support rail (Recommended for use on screens over 2000mm wide)

BENEFITS & FEATURES —

- Assemble on-site with pre-powder coated material – quick and easy!
- No welding, riveting or screwing off slats required
- No need for U channel or F section – Side frames affix directly to wall or post
- Patented side frames overcome out of square wall/posts: Friction fitting of slats into side frame allows slats to laterally adjust if needed
- Side frame suits 65mm x 16.5mm or 90mm x 16.5mm slats
- Variable slat spacing: Spacers for 5mm, 9mm or 20mm are available or easily achieve unique spacing by cutting to size from 100mm spacer blocks. For privacy/nil spacing, simply stack slats on top of each other

METHOD 2

PRE-ASSEMBLE PANELS —

Screen panels are assembled at a workshop or onsite. Slats are separated by snap in spacers OR via premium aluminium insert. Fully assembled panel is installed to wall/post with U channel or F section.

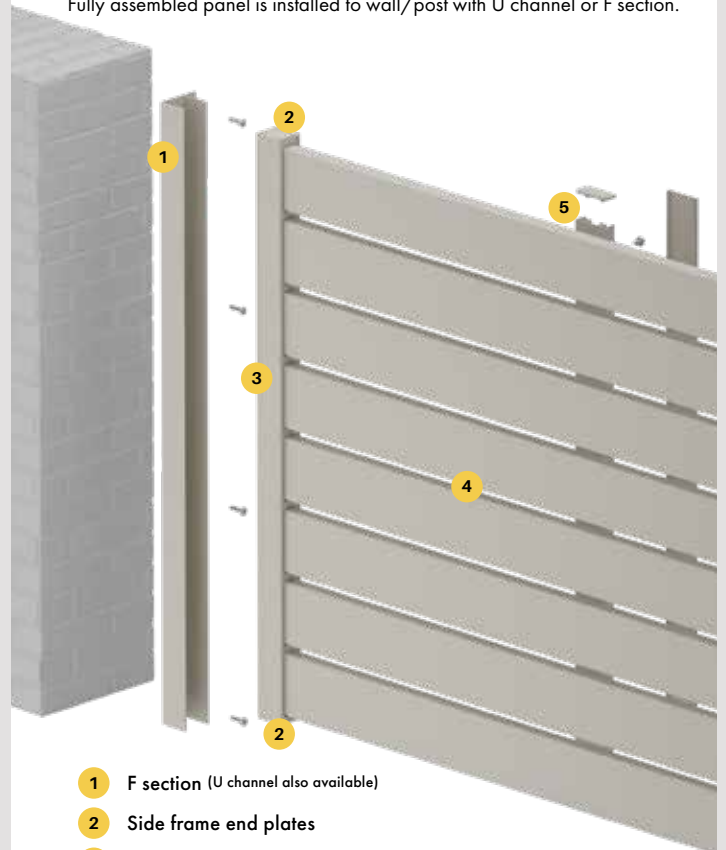

- 1 F section (U channel also available)
- 2 Side frame end plates
- 3 Xpress Plus side frame with premium aluminium spacer insert
- 4 65mm x 16.5mm slats (90mm x 16.5mm slats also available)
- 5 Centre support rail (Recommended for use on screens over 2000mm wide)

BENEFITS & FEATURES —

- Pre-assemble panels in workshop or onsite prior to actual install
- Install with U channel or F section – Overcome out of square walls/posts with forgiveness in U channel or F section cavity
- No welding, riveting or screwing off slats required
- Create gaps between slats using snap in spacers OR premium aluminium insert
- Premium insert suits 65x16.5mm slat only with 9 or 20mm slat pacing
- Snap in spacers of 5mm, 9mm or 20mm available or create your own unique spacer
- For privacy/nil spacing, simply stack slats on top of each other
- Use of premium aluminium insert spacer enables assembly of mill finish panels which may be powder coated as a completed unit
- Side frame suits 65mm x 16.5mm or 90mm x 16.5mm slats

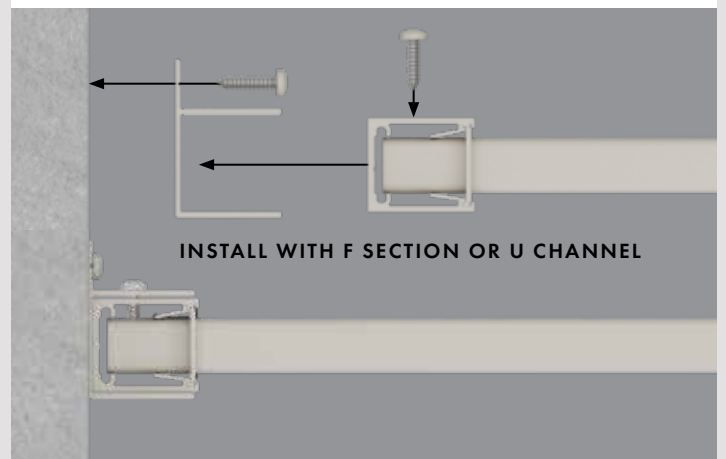
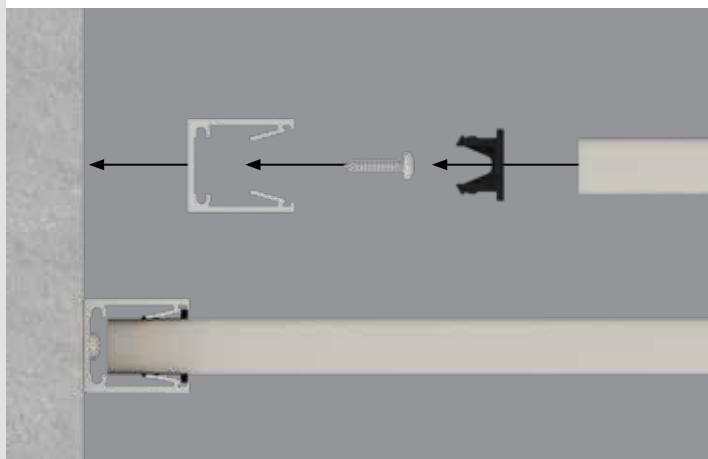

INSTALL WITH F SECTION OR U CHANNEL

SLAT OPTIONS

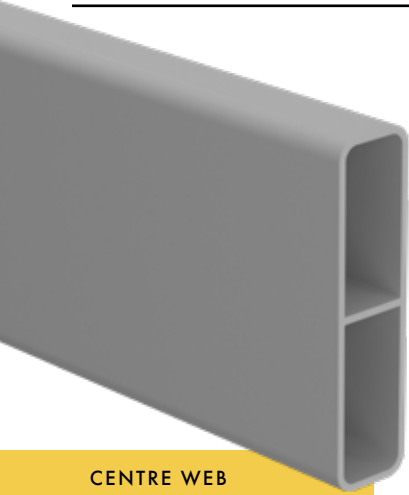

CENTRE WEB
ADDS STRENGTH &
RIGIDITY TO SLAT

65mm x 16.5mm slat with centre web

6100MM LONG

Order Code: XP-6100-S65

SOLD AS SINGLE LENGTHS,
BUNDLES OR PACK LOTS

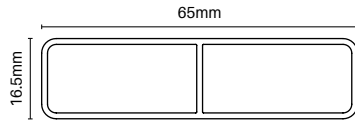

TECH SPECS

- PP 157 / AP 157
- Alloy 6063-T6
- 6100mm long
- 1.2mm wall thickness with centre web
- 3.5mm radius corners
- Genuine Australian Interpon powder coat
- lxx = 9.60 x 10E3 mmE4
- lyy = 83.09 x 10E3 mmE4

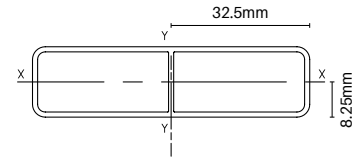

Finishes



Primrose & Paperbark also available from Brisbane, Adelaide & Perth depots

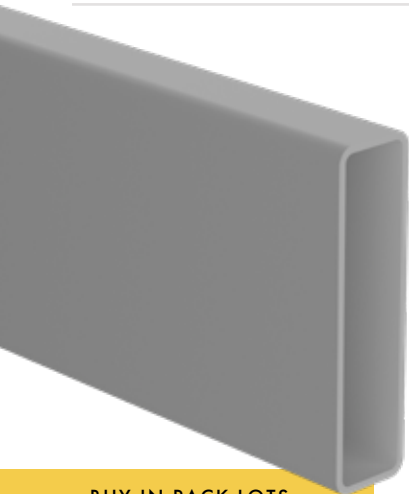

BUY IN PACK LOTS
FOR BEST PRICING!

65mm x 16.5mm slat

6500MM LONG

Order Code: XP-6500-E65

SOLD IN PACKS OF 96 ONLY
Not sold as single lengths

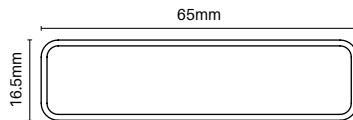

TECH SPECS

- PP 157 / AP 157
- Alloy 6063-T6
- 6500mm long
- 1.2mm wall thickness
- 3.5mm radius corners
- Genuine Australian Interpon powder coat
- lxx = 9.31 x 10E3 mmE4
- lyy = 83.09 x 10E3 mmE4

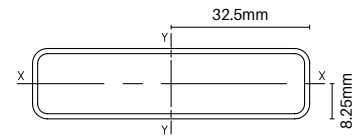

Finishes



CENTRE WEB
ADDS STRENGTH &
RIGIDITY TO SLAT

90mm x 16.5mm slat with centre web

6100MM LONG

Order Code: QS-6100-S90

SOLD AS SINGLE LENGTHS,
BUNDLES OR PACK LOTS

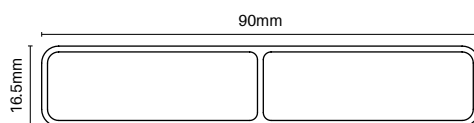

TECH SPECS

- PP 208 / AP 208
- Alloy 6063-T6
- 6100mm long
- 1.2mm wall thickness with centre web
- 3mm radius corners
- Genuine Australian Interpon powder coat
- lxx = 13.28 x 10E3 mmE4
- lyy = 202.57 x 10E3 mmE4

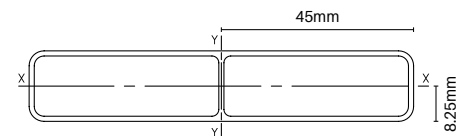

Finishes



XPRESS PLUS EXTRUSIONS



Side frame

28mm x 32mm

6000MM LONG

Order Code: **XPL-6000-SF**

PATENTED FRICTION FIT SYSTEM

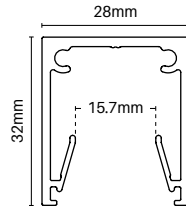

Finishes



Primrose & Paperbark also available from Brisbane, Adelaide & Perth depots

TECH SPECS

- PP 120 / AP 246
- Alloy 6060-T5
- 6000mm long
- 2x screw flutes in extrusion used for mechanical fixing of end plates
- Slats are firmly held by patented friction legs - no screwing, riveting or welding required
- lxx = 21.49 x 10E3 mmE4
- lyy = 25.27 x 10E3 mmE4

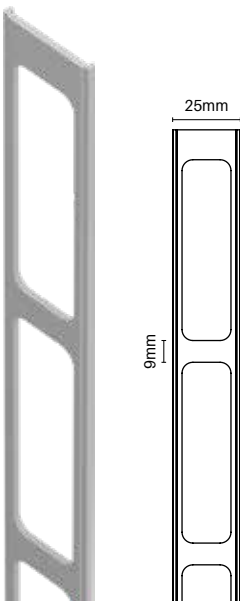
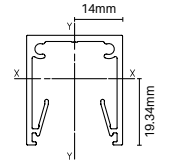

9MM SPACING

Aluminium insert

2100MM LONG

Order Code: **XPL-2100-INS09**

OPTIONAL EXTRA

Slide into Xpress Plus side frame for premium 9mm spacing finish

How to use:

1. Screw fix 1x end plate to bottom of side frame
2. Slide aluminium insert into side frame
3. Screw fix 1x end plate to top of side frame
4. Install slats into aluminium insert

Finishes



TECH SPECS

- PP 55 / AP 55
- Alloy 6063-T6
- 2100mm long
- Specially machined with 9mm spacing to suit 65x16.5mm slat
- lxx = 0.014 x 10E3 mmE4
- lyy = 2.267 x 10E3 mmE4

Important: To ensure correct function of insert

Before sliding in insert, trim cut side frame both ends to remove any excess build up of powder coat in slide channels

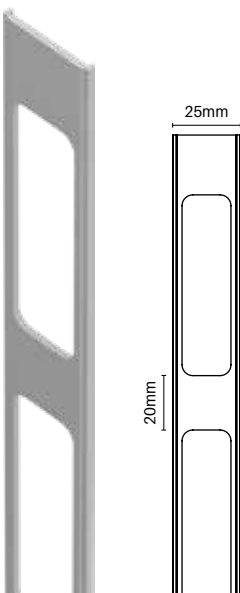
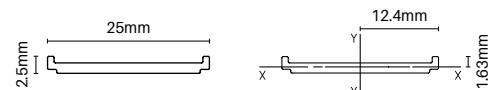

20MM SPACING

Aluminium insert

2100MM LONG

Order Code: **XPL-2100-INS20**

OPTIONAL EXTRA

Slide into Xpress Plus side frame for premium 20mm spacing finish

How to use:

1. Screw fix 1x end plate to bottom of side frame
2. Slide aluminium insert into side frame
3. Screw fix 1x end plate to top of side frame
4. Install slats into aluminium insert

Finishes



TECH SPECS

- PP 55 / AP 55
- Alloy 6063-T6
- 2100mm long
- Specially machined with 20mm spacing to suit 65x16.5mm slat
- lxx = 0.014 x 10E3 mmE4
- lyy = 2.267 x 10E3 mmE4

Important: To ensure correct function of insert

Before sliding in insert, trim cut side frame both ends to remove any excess build up of powder coat in slide channels

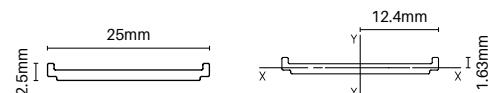

XPRESS PLUS EXTRUSIONS

U channel

6000MM LONG

Order Code: **XPL-6000-U**

OPTIONAL EXTRA

See page 18 – only required for 'method 2' assembly

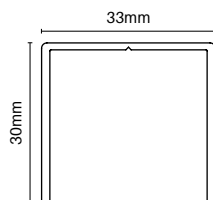

TECH SPECS

- PP 181 / AP 181
- Alloy 6063-T5
- 6000mm long
- 1.55mm side wall thickness; 1.3mm rear wall thickness
- $I_{xx} = 12.46 \times 10E3 \text{ mmE4}$
- $I_{yy} = 25.09 \times 10E3 \text{ mmE4}$

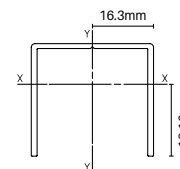

Finishes



BLACK
(B)



MONUMENT
(MN)



WOODLAND
GREY
(G)



SILVER
(S)



SURFMIST
(SM)



WHITE
(W)



BASALT
(BS)



DUNE
(D)



MILL
(M)

F section

6000MM LONG

Order Code: **XPL-6000-F**

OPTIONAL EXTRA

See page 18 – only required for 'method 2'

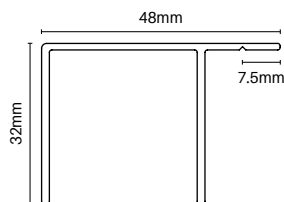

TECH SPECS

- PP 146 / AP 219
- Alloy 6060-T5
- 6000mm long
- 1.55mm side wall thickness; 1.3mm rear wall thickness
- Useful when installing in void situations
- $I_{xx} = 16.97 \times 10E3 \text{ mmE4}$
- $I_{yy} = 36.45 \times 10E3 \text{ mmE4}$

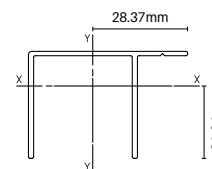

Finishes



BLACK
(B)



MONUMENT
(MN)



WOODLAND
GREY
(G)



SILVER
(S)



SURFMIST
(SM)



WHITE
(W)



BASALT
(BS)



DUNE
(D)



MILL
(M)

Centre support rail

5800MM LONG

Order Code: **XP-5800-CSR**

OPTIONAL EXTRA

Commonly used for screens 2000mm or wider to provide strength & rigidity to panel

Snap-on cover hides fixings – provides slimline sturdy support rail with no visible fixings

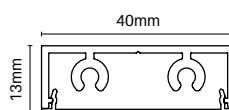

TECH SPECS

- PP 126 / AP 188
- Alloy 6063-T5
- 5800mm long
- Includes 2x screw flutes for cap insertion
- $I_{xx} = 1.73 \times 10E3 \text{ mmE4}$
- $I_{yy} = 26.34 \times 10E3 \text{ mmE4}$

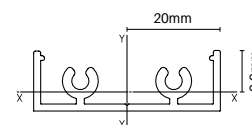

Finishes



BLACK
(B)



MONUMENT
(MN)



WOODLAND
GREY
(G)



SILVER
(S)



SURFMIST
(SM)



WHITE
(W)



BASALT
(BS)



DUNE
(D)



MILL
(M)

Primrose & Paperbark also available from Brisbane, Adelaide & Perth depots



XPRESS PLUS 135 ADAPTER

135 degree adapter

6000MM LONG

Order Code: XP-6000-135

TECH SPECS

- PP 109 / AP 163
- Alloy 6060 - T5
- Simple 2 step process:
 - (1) Adapter fixes to post/wall.
 - (2) Xpress Plus side frame then attached to adapter into which slats insert
- Ideal for when screens to run at 135 degree angle from post or wall
- lxx = 5.76 x 10E3 mmE4
- lyy = 25.92 x 10E3 mmE4

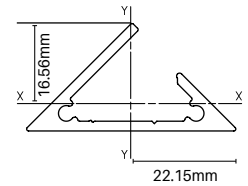
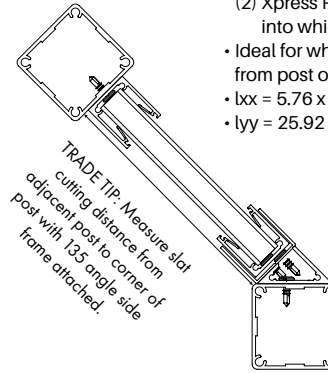
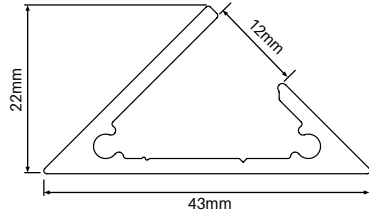

Finishes

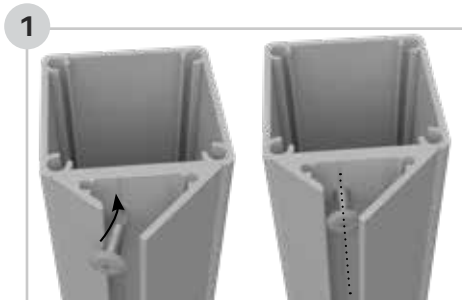

Place 135 adapter against post/wall. Insert screw into void opening. Screw fix adapter using V groove as a guide to fixing location.
TIP: pilot hole drill before screw fixing; max screw head size is 10mm.

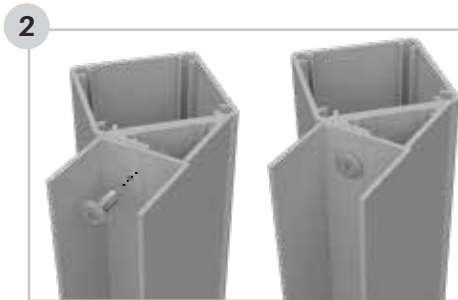

Xpress Plus Options: Attach U Channel to 135 adapter fixing through short leg of adapter.

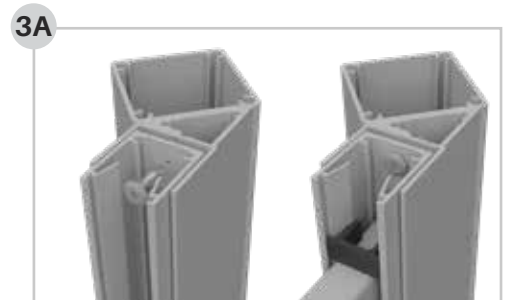

Xpress Plus BAYG: Install side frame into U channel screwing off side frame through the centre. Construct panel by installing slats and spacers one by one, starting from bottom.



Xpress Plus Premium: Construct panel using side frame, premium insert and slats. Then drop entire panel into U channel and screw off to fix into position.

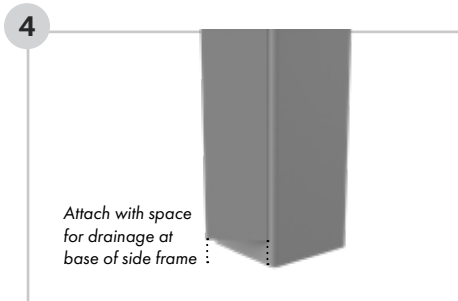

135 adapter should be cut so that it is elevated from floor and at the same length as Xpress Plus Side Frame.

SPACERS & EXTRAS

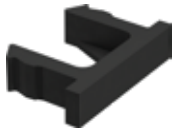

50 PACK Spacer block

5MM SPACING

Order Code: **XPL-SB-50PK-05MM**

- UV stabilised ASA thermoplastic - black
- Snaps into Xpress Plus side frame
- Provides 5mm space between slats
- Fast and easy install with side frame, slats and spacers

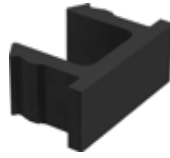

50 PACK Spacer block

9MM SPACING

Order Code: **XPL-SB-50PK-09MM**

- UV stabilised ASA thermoplastic - black
- Snaps into Xpress Plus side frame
- Provides 9mm space between slats
- Fast and easy install with side frame, slats and spacers



50 PACK Spacer block

20MM SPACING

Order Code: **XPL-SB-50PK-20MM**

- UV stabilised ASA thermoplastic - black
- Snaps into Xpress Plus side frame
- Provides 21mm space between slats
- Fast and easy install with side frame, slats and spacers



5 PACK Block

100MM LONG

Order Code: **XPL-BLOCK-5PK**

- UV stabilised ABS - black
- Snaps into Xpress Plus side frame
- 100mm long - can be easily cut to any spacer size
- Ideal for custom slat spacing



Louvre brackets

1x LEFT & 1x RIGHT
Black / Monument / Woodland Grey / Silver / Surfmist / White Basalt / Dune / Mill finish

Order Code: **QS-LB**

- 1x left and 1x right bracket per pack
- Die cast aluminium
- Suits 65x16.5mm slat - Press brackets onto end of slat then insert bracket into side frame
- Space brackets at nill, 5, 9, 20mm or any spacing desired
- Cost effective and fast way to achieve a fixed louvre finish

40° FINAL SLAT ANGLE

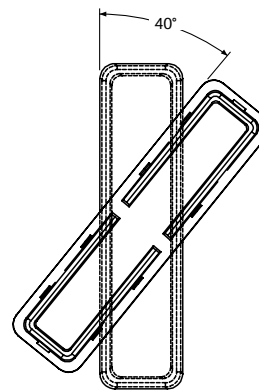

10 PACK Slat locking clip

Order Code: **XPL-SLATCLIP-10PK**

- Aluminium cast locking clip with SS304 self tapping screws
- Optional extra for install. Acts as mechanical fix to prevent chance of side frames splaying open. Consider if installing side frames to timber posts which may move/twist OR if side frames installed onto aluminium posts for large fence runs - Generally not required for side frame installs to pillars
- Hidden under side frame end plate



Self drilling wafer screws

10Gx16mm - BAG OF 100
Black / Monument / Woodland Grey / Silver / Surfmist / White Basalt / Dune / Mill finish

Order Code: **XP-SCREWS**

- Bags of 100 - 10G x 16mm self drilling wafer head zinc plated
- Powder coated heads for neat finish
- Ideal for fixing of side frames to U channel or F section



Touch up paint

150g SPRAY CAN
Black / Monument / Woodland Grey / Silver / Surfmist / White Basalt / Dune

Order Code:
PAINT-B/G/MN/S/SM/W/BS/D

- Colour match touch up paint
- Simply spray on for minor touch ups

END PLATES & MOUNTING ARMS

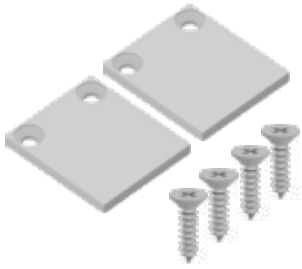

2 PACK Side frame end plate

28mm x 32mm

3MM THICK

Order Code: XPL-EP-2PK

MATES WITH XPL-6000-SF

Finishes

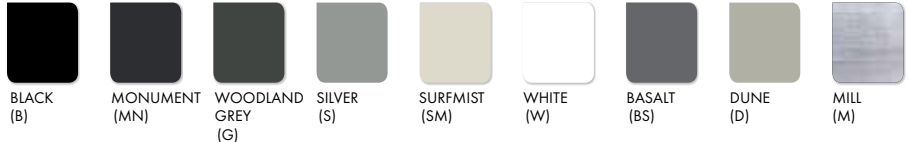

TECH SPECS

- Pack of 2 - affix to top and bottom of side frame
- 3mm thick
- Aluminium end plates fix into screw flute in Xpress Plus side frame
- Countersunk holes & screws provide neat flush fitting
- Mechanically fixed end plates ensure sturdy finish



Centre support rail cap 40mm x 13mm

3MM THICK

Order Code: XP-CSRC

- Nylon cap available in 5 colours
- Simply press into screw flutes in centre support rail
- Easy and fast fitting of cap

MATES WITH XP-5800-CSR

Finishes



Centre support rail top/bottom plate

Order Code: XP-BTP

- Aluminium with countersunk hole machining
- Optional extra to install with centre support rail
- Use to brace off top and/or bottom of centre support rail to structure above or below if desired
- Bracing centre support rail provides extra rigidity to panels - recommended for wide screens
- Available in same colours as end plates referenced above

MATES WITH XP-5800-CSR

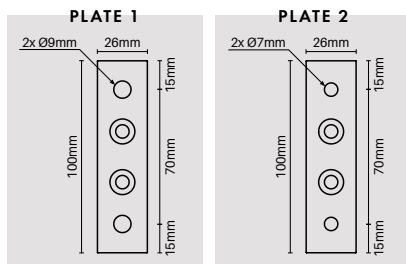
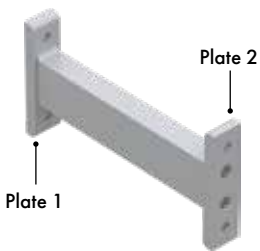

Side frame mounting arm

200MM or 400MM WIDE

Black / Monument / Woodland Grey
Silver / Surfmist / Mill finish

Order Code: XP-ARMSF (200mm W)

XP-ARMSF-400-M (400mm W - Mill finish)

- 2x welded fixing plates - 100mm L x 26mm W x 10mm D
- 2x Ø9mm fixing holes (plate 1) & 2x 7mm fixing holes (plate 2)

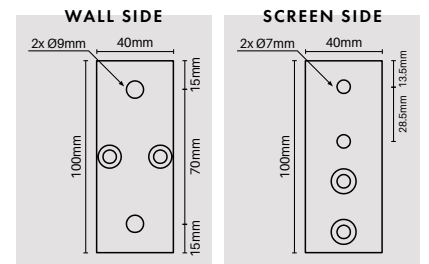
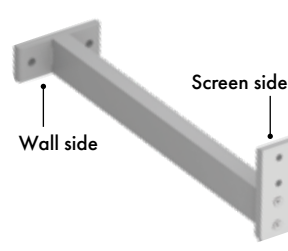
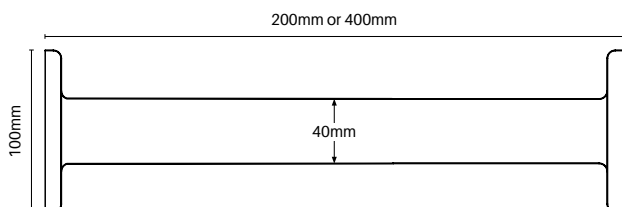

Centre support rail mounting arm

200MM or 392MM WIDE

Black / Monument / Woodland Grey
Silver / Surfmist / Mill finish

Order Code: XP-ARMCSR (200mm W)

XP-ARMCSR-392-M (392mm W - Mill finish)

- Specially designed shorter arm to match up with centre support rail when installing Xpress Plus side frames with 200mm or 400mm side frame support arms
- Wall side plate rotated horizontally so as to not protrude into window opening

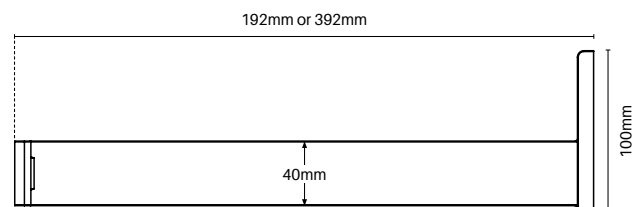



BUILD AS YOU GO SIDE FRAME SYSTEM

Slat Qty	Slat spacing	Height	Slat Qty	Slat spacing	Height
5	Nil	333mm	23	Nil	1508mm
	5mm	353mm		5mm	1618mm
	9mm	370mm		9mm	1713mm
	20mm	417mm		20mm	1972mm
6	Nil	398mm	24	Nil	1573mm
	5mm	423mm		5mm	1688mm
	9mm	444mm		9mm	1787mm
7	20mm	503mm	25	20mm	2059mm
	Nil	463mm		Nil	1639mm
	5mm	493mm		5mm	1759mm
8	9mm	519mm	26	9mm	1862mm
	20mm	590mm		20mm	2145mm
	Nil	528mm		Nil	1704mm
9	5mm	563mm	27	5mm	1829mm
	9mm	594mm		9mm	1936mm
	20mm	676mm		20mm	2231mm
10	Nil	594mm	28	Nil	1769mm
	5mm	634mm		5mm	1899mm
	9mm	668mm		9mm	2011mm
	20mm	763mm		20mm	2318mm
11	Nil	659mm	29	Nil	1834mm
	5mm	704mm		5mm	1969mm
	9mm	743mm		9mm	2086mm
	20mm	849mm		20mm	2404mm
12	Nil	724mm	30	Nil	1900mm
	5mm	774mm		5mm	2040mm
	9mm	817mm		9mm	2160mm
	20mm	935mm		20mm	2491mm
13	Nil	790mm	31	Nil	1965mm
	5mm	845mm		5mm	2110mm
	9mm	892mm		9mm	2235mm
	20mm	1022mm		20mm	2577mm
14	Nil	855mm	32	Nil	2030mm
	5mm	915mm		5mm	2180mm
	9mm	967mm		9mm	2309mm
	20mm	1108mm		20mm	2663mm
15	Nil	920mm	33	Nil	2096mm
	5mm	985mm		5mm	2251mm
	9mm	1041mm		9mm	2384mm
	20mm	1195mm		20mm	2750mm
16	Nil	986mm	34	Nil	2161mm
	5mm	1056mm		5mm	2321mm
	9mm	1116mm		9mm	2459mm
	20mm	1281mm		20mm	2836mm
17	Nil	1051mm	35	Nil	2226mm
	5mm	1126mm		5mm	2391mm
	9mm	1190mm		9mm	2533mm
	20mm	1367mm		20mm	2923mm
18	Nil	1116mm	36	Nil	2292mm
	5mm	1196mm		5mm	2462mm
	9mm	1265mm		9mm	2608mm
	20mm	1454mm		20mm	3009mm
19	Nil	1181mm	37	Nil	2357mm
	5mm	1266mm		5mm	2532mm
	9mm	1340mm		9mm	2682mm
	20mm	1540mm		20mm	3095mm
20	Nil	1247mm	38	Nil	2422mm
	5mm	1337mm		5mm	2602mm
	9mm	1414mm		9mm	2757mm
	20mm	1627mm		20mm	3182mm
21	Nil	1312mm	39	Nil	2487mm
	5mm	1407mm		5mm	2672mm
	9mm	1489mm		9mm	2832mm
	20mm	1713mm		20mm	3268mm
22	Nil	1377mm	40	Nil	2553mm
	5mm	1477mm		5mm	2743mm
	9mm	1563mm		9mm	2906mm
	20mm	1799mm		20mm	3355mm
	Nil	1443mm		Nil	2618mm
	5mm	1548mm		5mm	2813mm
	9mm	1638mm		9mm	2981mm
	20mm	1886mm		20mm	3441mm

65mm slat spacing table

Slat Qty

Total number of slats required for height shown in corresponding rows

Slat spacing

Height of gap between each slat

Note: Spacer inserts for 20mm spacing are supplied at 21mm

Height

Overall height of side frame screen includes allowance for 3mm end plates at top & bottom of screen

- **Bottom slat:** Sit directly onto aluminium end plate. No spacer is used under bottom of first slat
- **Top slat:** No spacer is used between top slat and finishing top plate



Note: If using slat locking clip at top of screen, add 5mm to 'Height' to allow extra 5mm gap at top of screen

BUILD AS YOU GO SIDE FRAME SYSTEM

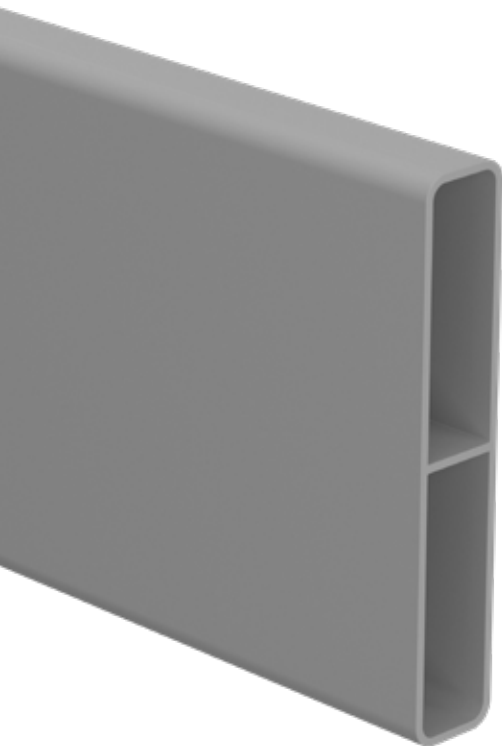

Slat Qty	Slat spacing	Height	Slat Qty	Slat spacing	Height
5	Nil	458	23	Nil	2083
	5mm	478		5mm	2193
	9mm	495		9mm	2288
	20mm	542		20mm	2547
6	Nil	548	24	Nil	2173
	5mm	573		5mm	2288
	9mm	594		9mm	2387
7	20mm	653	25	20mm	2659
	Nil	638		Nil	2264
	5mm	668		5mm	2384
	9mm	694		9mm	2487
8	20mm	765	26	20mm	2770
	Nil	728		Nil	2354
	5mm	763		5mm	2479
9	9mm	794	27	9mm	2586
	20mm	876		20mm	2881
	Nil	819		Nil	2444
	5mm	859		5mm	2574
10	9mm	893	28	9mm	2686
	20mm	988		20mm	2993
	Nil	909		Nil	2534
	5mm	954		5mm	2669
11	9mm	993	29	9mm	2786
	20mm	1099		20mm	3104
	Nil	999		Nil	2625
	5mm	1049		5mm	2765
12	9mm	1092	30	9mm	2885
	20mm	1210		20mm	3216
	Nil	1090		Nil	2715
	5mm	1145		5mm	2860
13	9mm	1192	31	9mm	2985
	20mm	1322		20mm	3327
	Nil	1180		Nil	2805
	5mm	1240		5mm	2955
14	9mm	1292	32	9mm	3084
	20mm	1433		20mm	3438
	Nil	1270		Nil	2896
	5mm	1335		5mm	3051
15	9mm	1391	33	9mm	3184
	20mm	1545		20mm	3550
	Nil	1361		Nil	2986
	5mm	1431		5mm	3146
16	9mm	1491	34	9mm	3284
	20mm	1656		20mm	3661
	Nil	1451		Nil	3076
	5mm	1526		5mm	3241
17	9mm	1590	35	9mm	3383
	20mm	1767		20mm	3773
	Nil	1541		Nil	3167
	5mm	1621		5mm	3337
18	9mm	1690	36	9mm	3483
	20mm	1879		20mm	3884
	Nil	1631		Nil	3257
	5mm	1716		5mm	3432
19	9mm	1790	37	9mm	3582
	20mm	1990		20mm	3995
	Nil	1722		Nil	3347
	5mm	1812		5mm	3527
20	9mm	1889	38	9mm	3682
	20mm	2102		20mm	4107
	Nil	1812		Nil	3437
	5mm	1907		5mm	3622
21	9mm	1989	39	9mm	3782
	20mm	2213		20mm	4218
	Nil	1902		Nil	3528
	5mm	2002		5mm	3718
22	9mm	2088	40	9mm	3881
	20mm	2324		20mm	4330
	Nil	1993		Nil	3618
	5mm	2098		5mm	3813
	9mm	2188		9mm	3981
	20mm	2436		20mm	4441

90mm slat spacing table

Slat Qty

Total number of slats required for height shown in corresponding rows

Slat spacing

Height of gap between each slat

Note: Spacer inserts for 20mm spacing are supplied at 21mm

Height

Overall side frame screen height includes allowance for 3mm end plates at top & bottom of screen

- **Bottom slat:** Sit directly onto aluminium end plate. No spacer is used under bottom of first slat
- **Top slat:** No spacer is used between top slat and finishing top plate

Note: If using slat locking clip at top of screen, add 5mm to 'Height' to allow extra 5mm gap at top of screen



TRADE TIP: CENTRE SUPPORT RAIL

The centre support rail is commonly used to brace off slats in wider screens. If you need to add extra rigidity to the screen, the centre support rail can also be screw fixed at top and/or bottom with our centre support rail **top/bottom plate**. This is ideal for use on wide slat screen panels or panels installed in high wind areas. The specially designed **top/bottom plate** seamlessly attaches to the centre support rail extrusion providing a hidden screw fixed bracing system.

Centre support rail top/bottom plate

See pages 11 & 31 for more details



Specially machined plate screw fixes to screw flutes in centre support rail extrusion. Fix to top and/or bottom of centre support rail. Top/bottom plate is now mechanically attached to centre support rail.

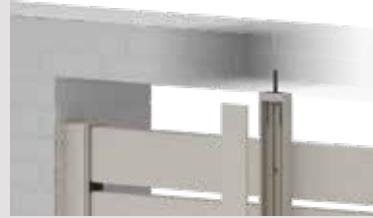

Fix off centre support rail to horizontal beam, ceiling or floor via sturdy single fixing. Snap on centre support rail cover hides fixings for a clean finish.

Ideal for wider screen panels used in patios

Centre support rail can extend past top and bottom slats for screw fix bracing into top beam and floor. Adds significant rigidity to screen panels.

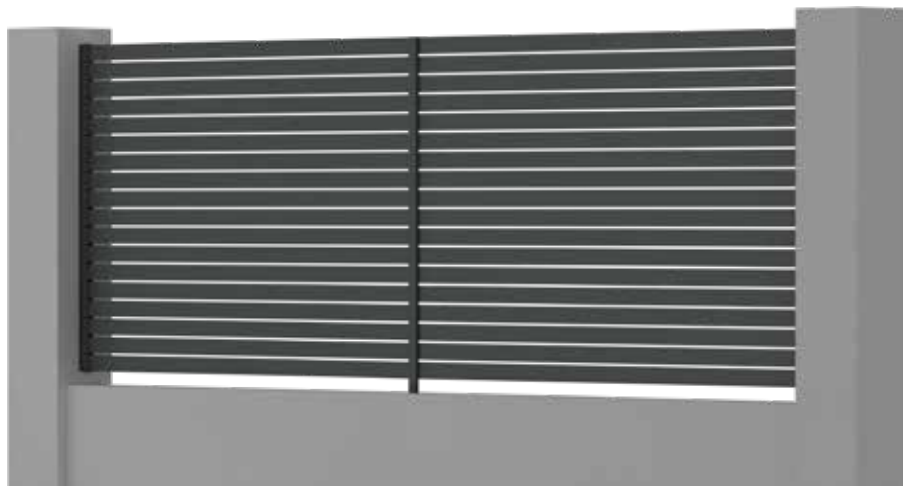
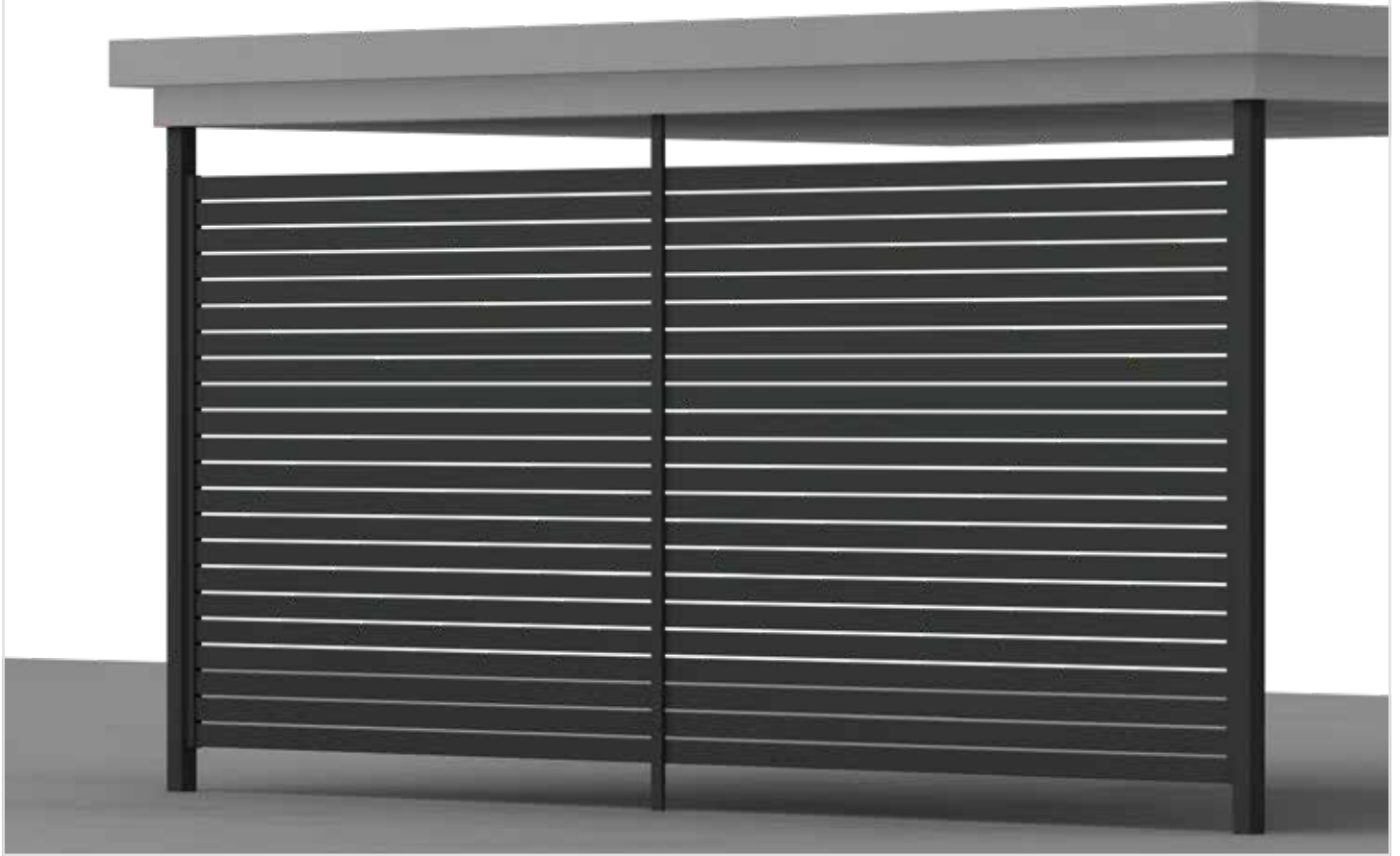

Ideal for screw fix bracing at bottom for wide screen panels between pillars

SLAT CAPS & TOPPER



SLAT CAPS & TOPPER

65MM SLAT CAPS

Suits 65x16.5mm slats

Order Code: XP-EC65-4PK



Finishes

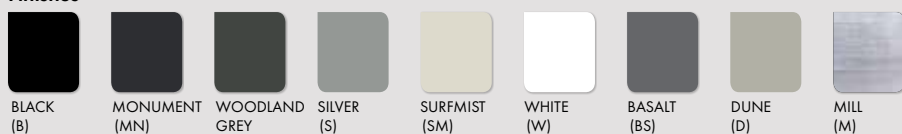

Primrose & Paperbark also available from Brisbane, Adelaide & Perth depots

TECH SPECS

- Alloy ADC12 aluminium flat end cap
- Available powder coated or mill finish
- Suits GO's 65x16.5mm slat
- Press into end of slat
- Innovative design feature with polymer inserts ensures tight press in fit (inserts supplied with every cap)
- Internally slotted allowing end cap to be used with webbed or non-webbed slats
- Sold as a 4 pack

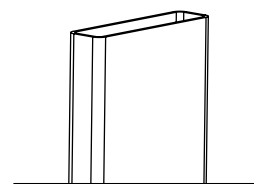
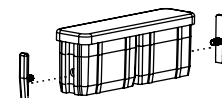

DESIGN INNOVATION

Tapered polymer insert can be installed on one or both sides of cap. Use inserts if cap not a tight fit in slat.

90MM SLAT CAPS

Suits 90x16.5mm slats

Order Code: XP-EC90-4PK



Finishes



TECH SPECS

- Alloy ADC12 aluminium flat end cap
- Available powder coated or mill finish
- Suits GO's 90x16.5mm slat
- Press into end of slat
- Innovative design feature with polymer inserts ensures tight press in fit (inserts supplied with every cap)
- Internally slotted allowing end cap to be used with webbed or non-webbed slats
- Sold as a 4 pack

FEDERATION TOPPER

Suits 65x16.5mm slats

Order Code: XP-FEDTOP-4PK



Finishes



TECH SPECS

- Use to achieve a vertical picket fence look
- Alloy ADC12 aluminium federation topper
- Suits GO's 65x16.5mm slat
- Available powder coated pearl white or mill finish
- Press into end of slat
- Innovative design feature with polymer inserts ensures tight press in fit (inserts supplied)
- Internally slotted allowing end cap to be used with webbed or non-webbed slats
- Sold as a 4 pack

DESIGN INNOVATION

Tapered polymer insert can be installed on one or both sides of topper. Use inserts if topper not a tight fit in slat.

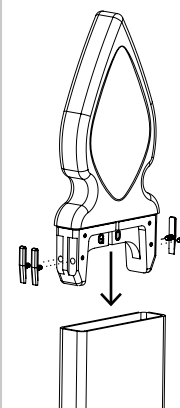

SLAT CAPS & TOPPER

Aluminium slat installed vertically allows for a number of stylish design options including radiator/blade fencing or picket top fencing. A significant advantage of powder coated aluminium is the minimal ongoing maintenance required.

GO's systems allow for easy NON-WELD assembly achieved via hidden screw fixings. The innovative horizontal top & bottom rails have an open back cavity allowing easy entry for screw fixing of slats. Screws are hidden by a simple snap in cover giving a seamless finish.

The simple screw fix system provides a significant cost saving versus traditional fully welded/fabricated panels.

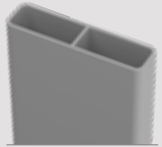

- 1** **65x16.5mm slat with centre web**
6100mm long
XP-6100-S65

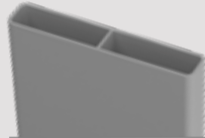

- 2** **90x16.5mm slat with centre web**
6100mm long
QS-6100-S90



- 3** **45x45mm batten**
6100mm long
XBAT-6100-045X045



- 4** **Rear snap in infill**
4000mm long
XP-4000-COVER

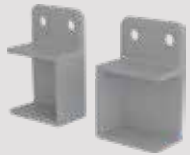

- 5** **Aluminium horizontal bracket**
Pack of 2 – Open side
Affix brackets to post or wall
XBAT-BH20



- 6** **12G x 65mm screws**
hex flange head
Pack of 10
XP-SCREWSGF-10PK
• Use for radiator style



- 7** **65mm end cap**
Pack of 4
XP-EC65-4PK



- 8** **90mm end cap**
Pack of 4
XP-EC90-4PK



- 9** **Federation topper**
Pack of 4
XP-FEDTOP-4PK



- 10** **Pan head screws**
10G x 16mm – Pack of 100
XP-SCREWS

RADIATOR/BLADE FENCING

NO WELDING REQUIRED

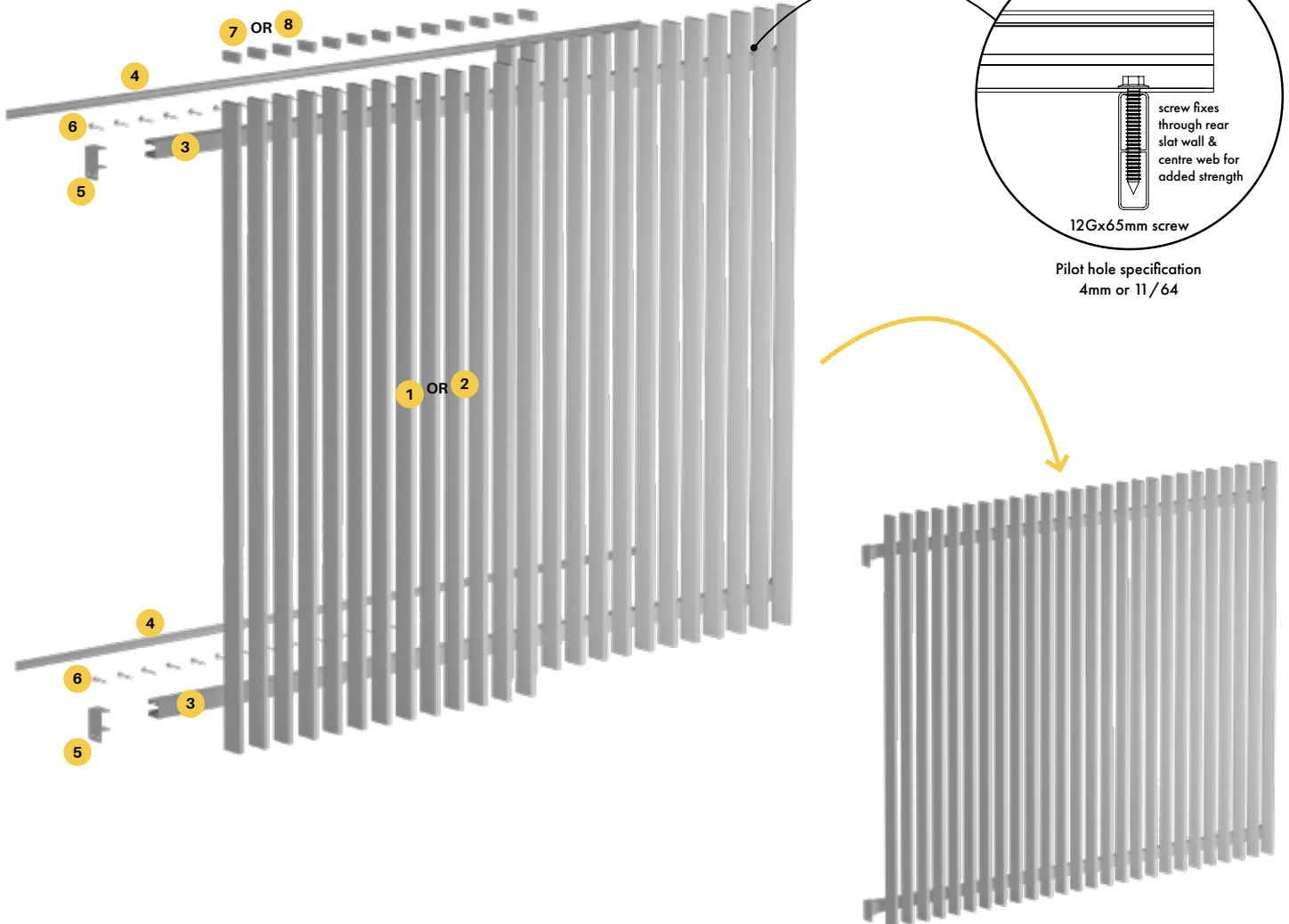

SLAT CAPS & TOPPER

PALING FENCING

NO WELDING REQUIRED

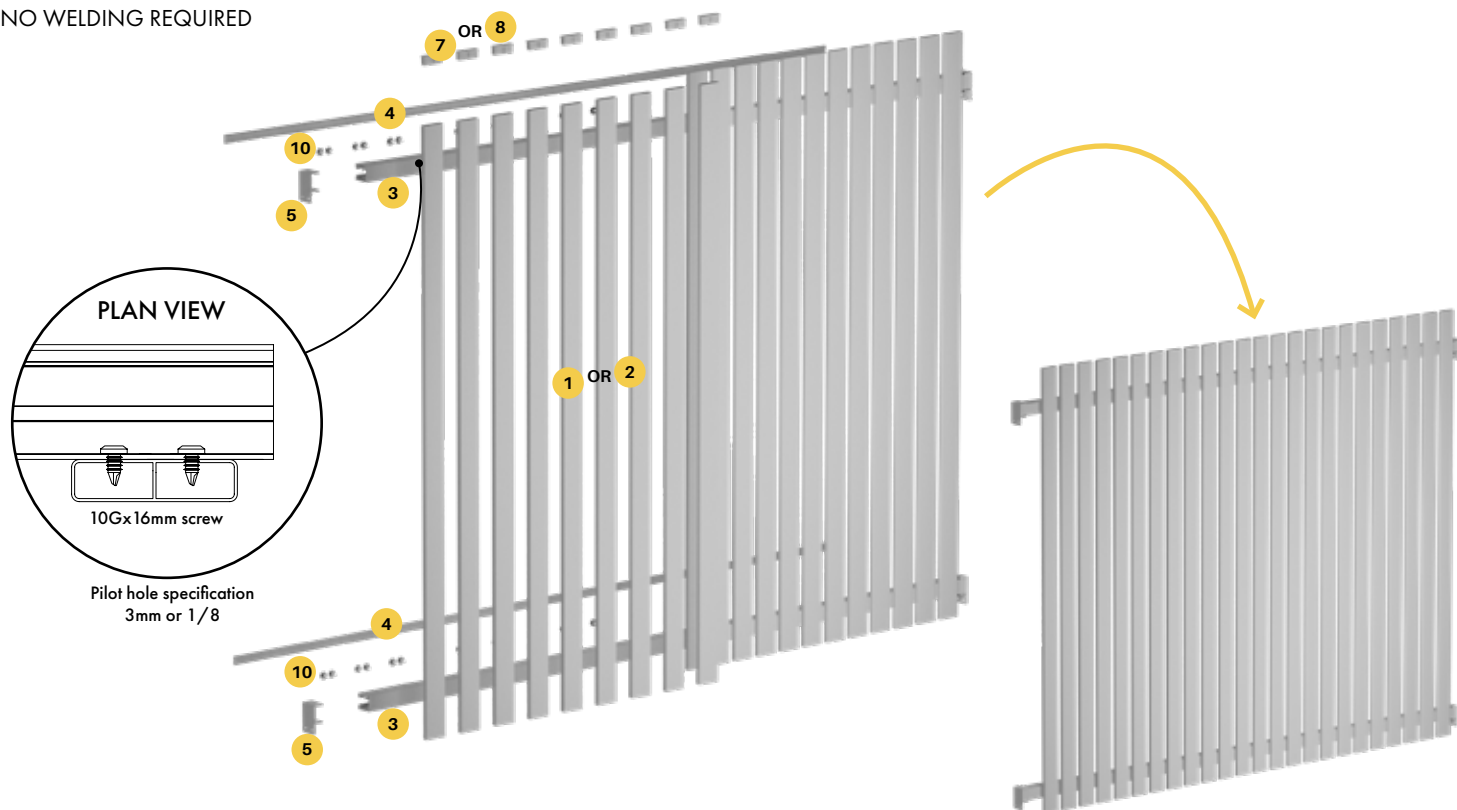

FEDERATION/PICKET FENCING

NO WELDING REQUIRED

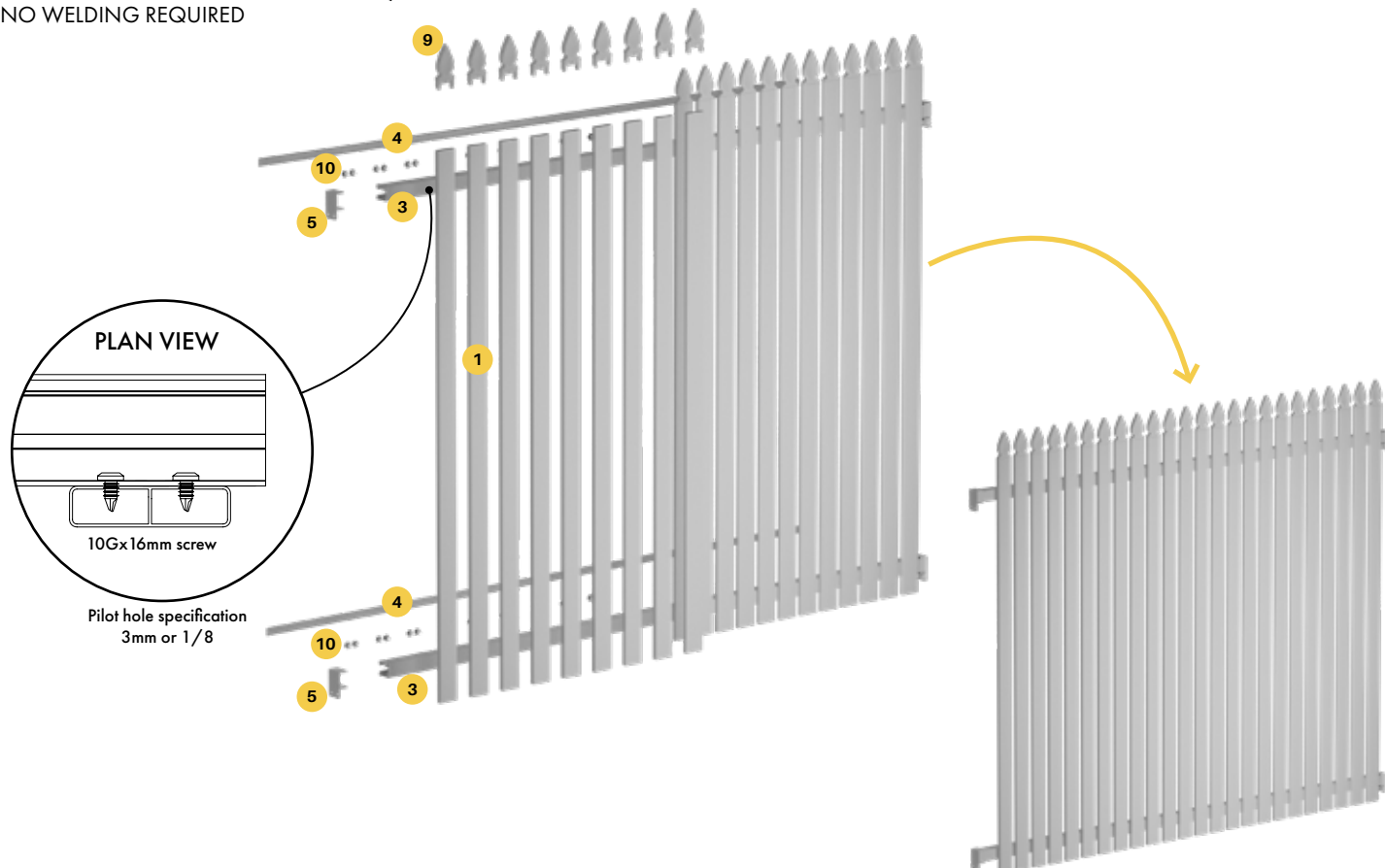

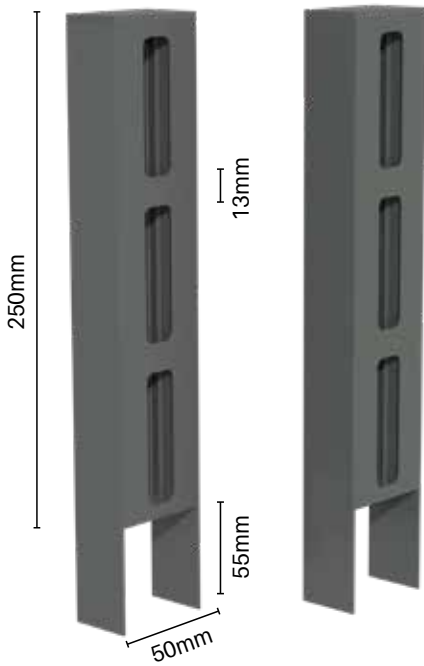

Screen Topper

SIDE FRAMES – PAIR OF 2

Order Code: **LT2-SF-0250-B**
LT2-SF-0250-BS
LT2-SF-0250-G
LT2-SF-0250-MN
LT2-SF-0250-PB
LT2-SF-0250-P
LT2-SF-0250-SM

Finishes



TECH SPECS

- 250mm extension for COLORBOND® steel fencing to add slat screening toppers
- 13mm gap between slats
- Suits EXISTING or NEW fence installations
- Sturdy powder coated aluminium side frames (pair of 2)
- Simply push in 65x16.5mm slats x 3 (slats sold separately)
- Patented friction fit - no welding or screwing of slats needed
- Slats are held firmly in position

INSTALL WITH OUR SELECTION OF 65X16.5mm SLATS

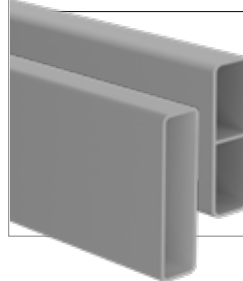

Available with centre web or without. Refer page 27 for more info

Option 1

TOPPER ABOVE C SECTION POSTS AND RAIL

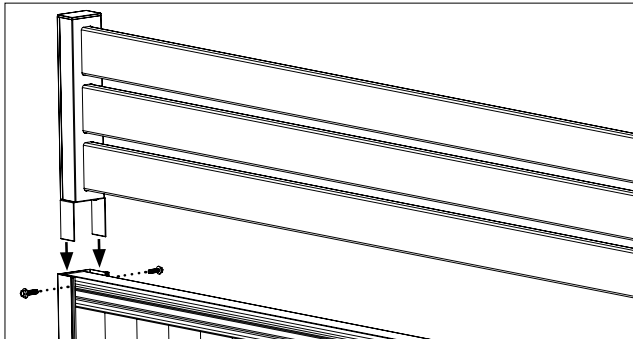

1

Install Topper by inserting the U-bracket located on the bottom of the topper between the top rail and C section post and secure post off both sides with tek screws.

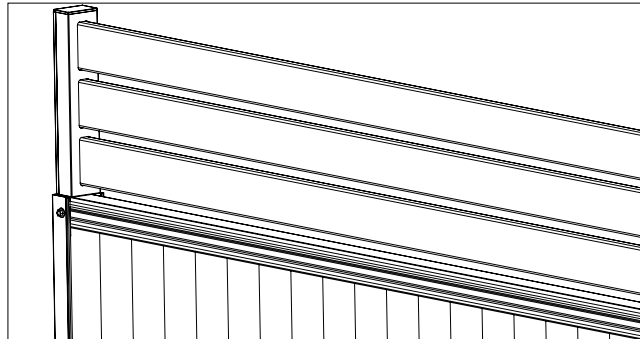

Option 2

TOPPER FITTED INSIDE C SECTION POSTS

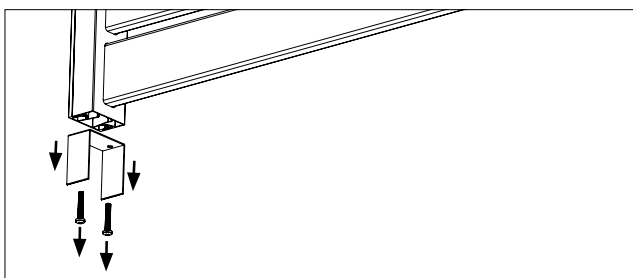

1

Remove the U-bracket located on the bottom of the Topper by unscrewing the 2 screws.

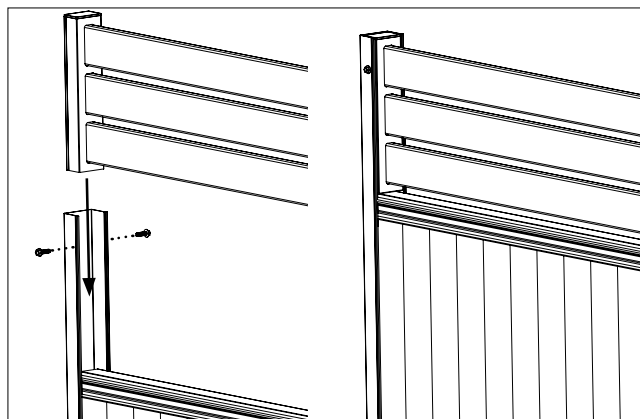

2

Insert the Topper into the C section posts securing into position both sides with tek screw.



alumawall

Stackable sleeper

An extruded aluminium stackable sleeper designed to be used under steel panel fences or as a retaining wall sleeper.

- > Sturdy aluminium design with high quality powder coat finish
- > Fits neatly into 'C' section posts of common steel panel fencing brands
- > Perfect for preventing weeds or debris from protruding through gaps in fence
- > Can also be used to level or increase the base height of the fence
- > 2385mm long x 150mm high x 50mm wide – check your 'C' section posts to ensure correct fitting
- > Easy width adjustment – simply cut to desired width
- > Specially designed heavy duty post available for retaining wall installations
- > Sleeper comes with two free black nylon end caps

-  Primrose GD037A
-  Paperbark GU114A
-  Woodland grey GL205A
-  Monument GL229A

Easily stackable!

1 SLEEPER
150mm high

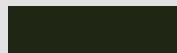

2 SLEEPERS
280mm high

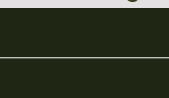

3 SLEEPERS
410mm high

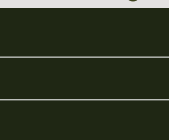

4 SLEEPERS
540mm high

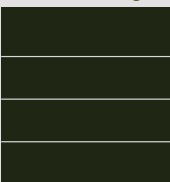

Primrose **AWALL-2385-P**
Paperbark **AWALL-2385-PB**
Woodland Grey **AWALL-2385-G**
Monument **AWALL-2385-MN**

- Retaining wall system -

Stackable sleeper

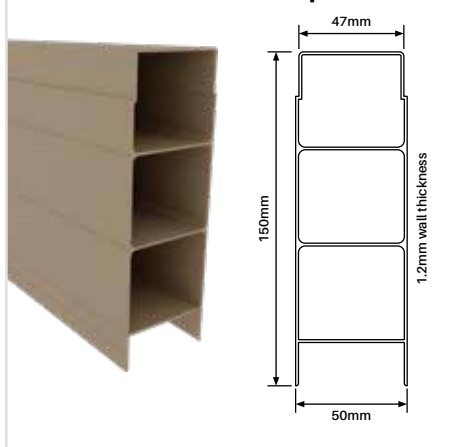

Retaining wall post

1700mm H

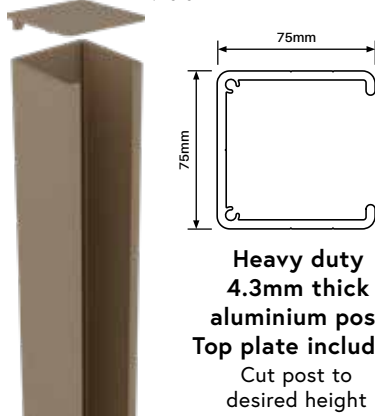

Top plate

OPTIONAL EXTRA. POSTS COME WITH TOP PLATE



- Only required if cutting down posts to shorter lengths & extra top plates are required
- Available in Woodland Grey, Monument, Primrose & Paperbark

Order code: AWALL-TP-G/MN/P/PB

- | | | |
|---|----------------------|---------------------------------------|
|  | Primrose GD037A | POST CODES:
AWALL-1700-1W-P |
|  | Paperbark GU114A | AWALL-1700-1W-PB |
|  | Woodland grey GL205A | AWALL-1700-1W-G |
|  | Monument GL229A | AWALL-1700-1W-MN |

*Post includes top plate

Easily adaptable for 1 way, 2 way and 90° corner configurations

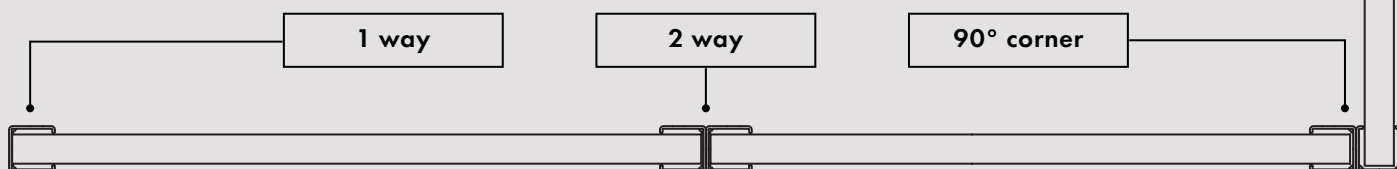

To join posts for 2 way or corner configurations, simply screw together using 15mm x 10G self tapping screws



xpress plus

PREMIUM POST SYSTEM OVERVIEW

**Australia's leading
slat screen system**

**Designed & patented
Exclusive to GO & AO**

**Save time
& money**

Xpress Plus Premium post system is Australia's premier horizontal slat screening system for fencing. Featuring 50x50mm square posts, patented internal legs firmly hold slats in position without need of screwing, riveting or welding each slat. Slats are recessed into the post for a neat slimline finish. The system enables the fastest and easiest onsite assembly of slat fencing with pre-powder coated stock.

Horizontal slat screening post system

ASSEMBLE ON-SITE —

Simply install posts and insert slats working from bottom to top. Slats are separated by snap in spacers available in 5mm, 9mm or 20mm heights. 100mm long spacers also available for cutting to specific gap if needed.

Starting height of slats is set by using snap-in height adjustable spacer.

EASY QUOTING & PLANNING —

Quickly and accurately plan and quote a fence using our free and easy to use calculator in Excel format. Simply put in your fence shape, height and span. Instantly receive post centres and a bill of materials for your fence.

Fast, easy and accurate!

LONG LENGTH SUPPLY OR CUSTOM CUT TO SIZE —

Long length extrusion is available or simply provide us your fence spans and we can custom cut post & slat to size.

COMPLETE SYSTEM —

50x50mm aluminium posts available in 1 way, 2 way and 90 degree configurations. Slimline side frames available separately as well as matching pedestrian and sliding gates. All systems feature patented non-weld assembly.

SAVE TIME & MONEY —

Enjoy the fastest and easiest slat fence system available utilising pre-powder coated stock. Install posts with slats in the same day. The patented system means only 1 person is required for install.

No need for screwing, welding or riveting each slat.

STYLISH DESIGN —

The patented system enables slats to be inserted directly into the 50x50mm post for a slimline finish. No need for U channel or F section.

EXTRUDED & POWDER COATED IN AUSTRALIA

HIGHEST QUALITY FINISHES —

Our range of genuine Interpon D1000 series powder coat finishes has been carefully selected to include the most sought after colours on offer.

All components are suitably pre-treated prior to powder coating and are applied by fully accredited coating facilities.

B Black SATIN GN150A	MN Monument MATT GL229A	G Woodland Grey MATT GL205A
S Palladium Silver PEARL GY184C	SM Surfmist MATT GA236A	W Pearl White GLOSS GA078A
BS Basalt SATIN GP108A	D Dune SATIN GP152A	M Mill

Note: Colours displayed are a guide only

POST SYSTEM OVERVIEW

Stylish design with fast and easy installation – no welding or riveting required

BUILD ON-SITE WITH FAST & EASY INSTALL

Install pre-powder coated 50x50mm posts (core drill or base plated) and insert slats working from bottom to top.

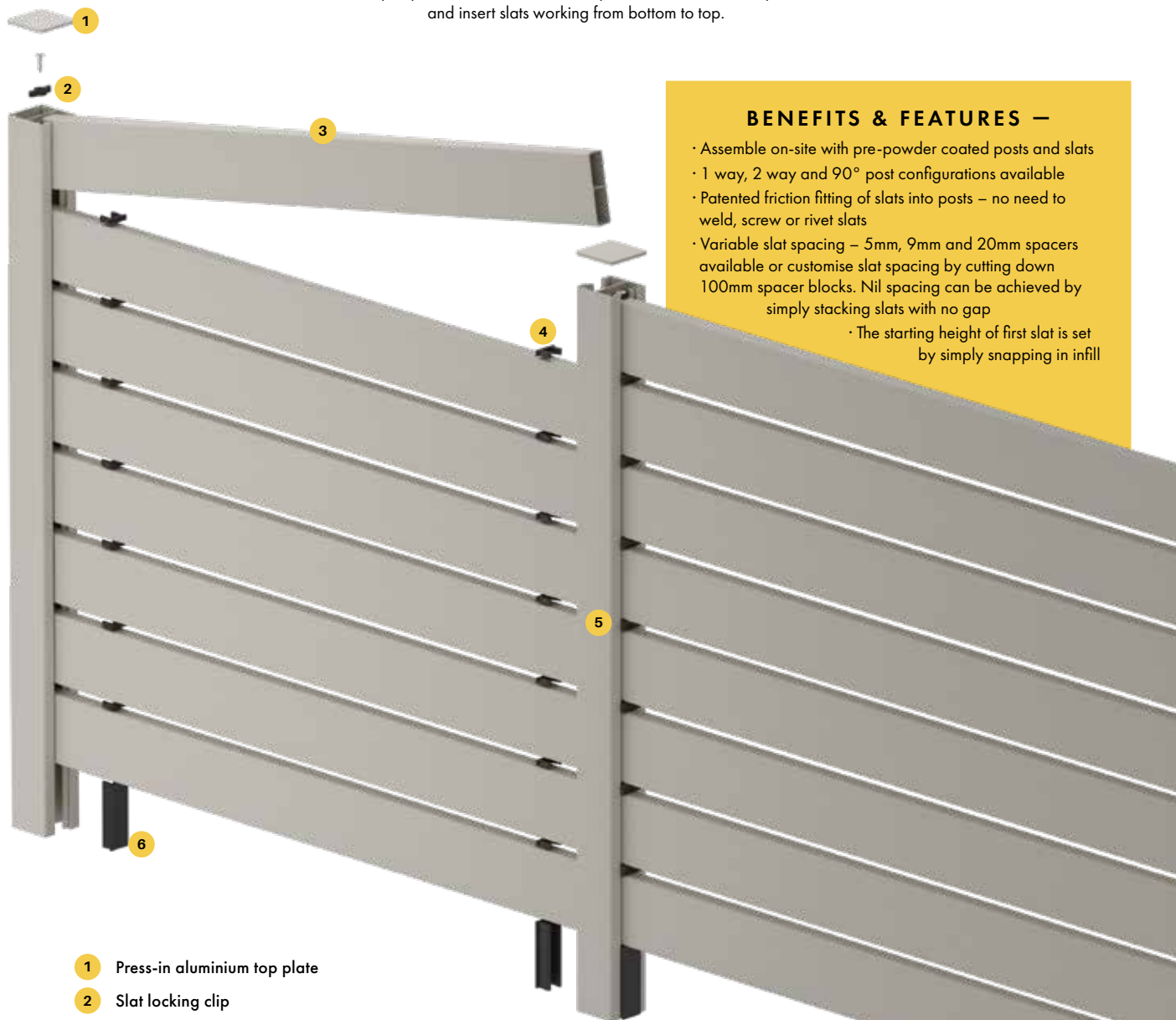

BENEFITS & FEATURES –

- Assemble on-site with pre-powder coated posts and slats
- 1 way, 2 way and 90° post configurations available
- Patented friction fitting of slats into posts – no need to weld, screw or rivet slats
- Variable slat spacing – 5mm, 9mm and 20mm spacers available or customise slat spacing by cutting down 100mm spacer blocks. Nil spacing can be achieved by simply stacking slats with no gap
- The starting height of first slat is set by simply snapping in infill

- 1 Press-in aluminium top plate
- 2 Slat locking clip
- 3 65mm x 16.5mm slats (90mm x 16.5mm slats also available)
- 4 Snap-in spacers
- 5 Patented 50x50mm post
- 6 100mm high spacer block (cut down to adjust first slat starting height)

**AUSTRALIAN MADE
& POWDER COATED
ALUMINIUM**

SLATS RECESS INTO PATENTED FRICTION FIT POSTS FOR A NEAT FINISH

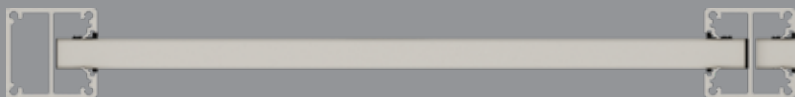

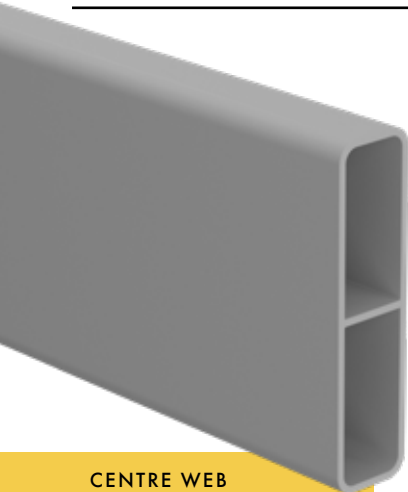

CENTRE WEB
ADDS STRENGTH &
RIGIDITY TO SLAT

**65mm x 16.5mm slat
with centre web**

6100MM LONG

Order Code: XP-6100-S65

SOLD AS SINGLE LENGTHS,
BUNDLES OR PACK LOTS

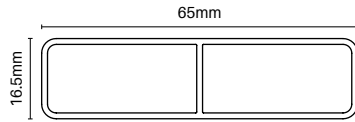

TECH SPECS

- PP 157 / AP 157
- Alloy 6063-T6
- 6100mm long
- 1.2mm wall thickness with centre web
- 3.5mm radius corners
- Genuine Australian Interpon powder coat
- lxx = 9.60 x 10E3 mmE4
- lyy = 83.09 x 10E3 mmE4

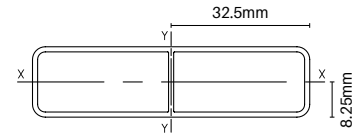

Finishes

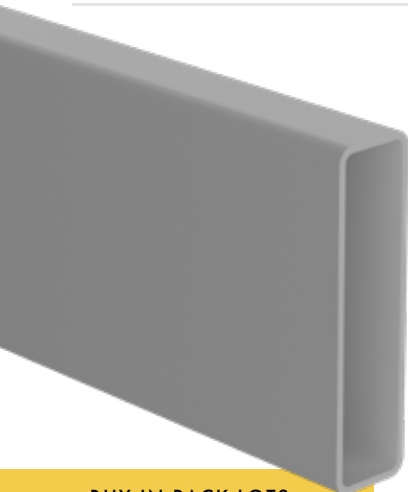

BUY IN PACK LOTS
FOR BEST PRICING!

65mm x 16.5mm slat

6500MM LONG

Order Code: XP-6500-E65

SOLD IN PACKS OF 96 ONLY
Not sold as single lengths

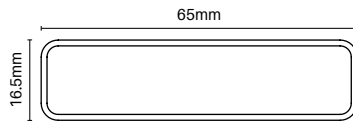

TECH SPECS

- PP 157 / AP 157
- Alloy 6063-T6
- 6500mm long
- 1.2mm wall thickness
- 3.5mm radius corners
- Genuine Australian Interpon powder coat
- lxx = 9.31 x 10E3 mmE4
- lyy = 83.09 x 10E3 mmE4

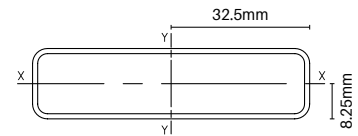

Finishes



CENTRE WEB
ADDS STRENGTH &
RIGIDITY TO SLAT

**90mm x 16.5mm slat
with centre web**

6100MM LONG

Order Code: QS-6100-S90

SOLD AS SINGLE LENGTHS,
BUNDLES OR PACK LOTS

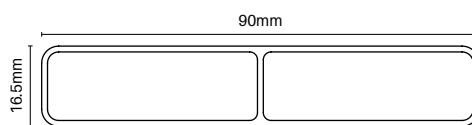

TECH SPECS

- PP 208 / AP 208
- Alloy 6063-T6
- 6100mm long
- 1.2mm wall thickness with centre web
- 3mm radius corners
- Genuine Australian Interpon powder coat
- lxx = 13.28 x 10E3 mmE4
- lyy = 202.57 x 10E3 mmE4

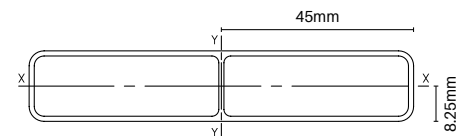

Finishes

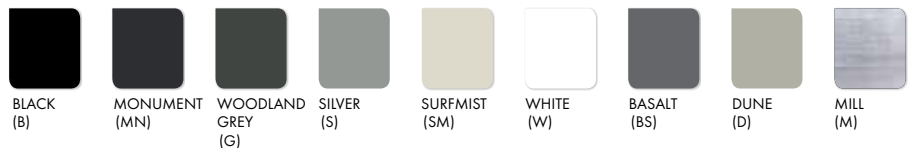

POST SYSTEM EXTRUSIONS



PATENTED FRICTION FIT SYSTEM

One way post

6000MM LONG

Order Code: XPL-6000-1W

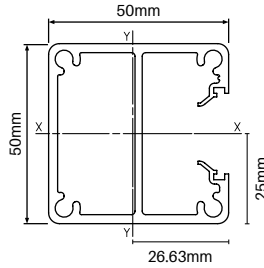

TECH SPECS

- PP 200 / AP 360
- Alloy 6060-T5
- 6000mm long
- 2.5mm wall thickness
- Patented friction legs for non-weld slat assembly
- Maximum slat insertion depth = 24mm
- lxx = 196.53 x 10E3 mmE4
- lyy = 155.26 x 10E3 mmE4

4x screw flutes in post allow tight fit of press in flat aluminium top plate. *Top plate sold separately*

Optional base plate can be attached using screw flutes for base plated post installations.

Finishes



PATENTED FRICTION FIT SYSTEM

Two way post

6000MM LONG

Order Code: XPL-6000-2W

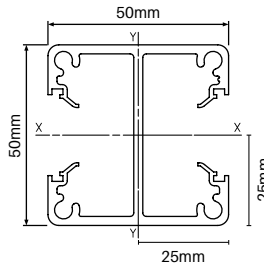

TECH SPECS

- PP 200 / AP 523
- Alloy 6060-T5
- 6000mm long
- 2.5mm wall thickness
- Patented friction legs for non-weld slat assembly
- Maximum slat insertion depth = 24mm
- lxx = 200.75 x 10E3 mmE4
- lyy = 132.93 x 10E3 mmE4

4x screw flutes in post allow tight fit of press in flat aluminium top plate. *Top plate sold separately*

Optional base plate can be attached using screw flutes for base plated post installations.

Finishes

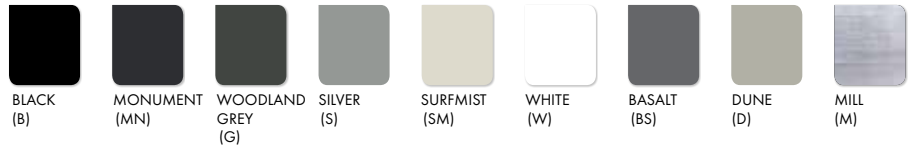

PATENTED FRICTION FIT SYSTEM

90° corner post

6000MM LONG

Order Code: XPL-6000-90

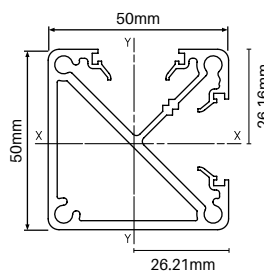

TECH SPECS

- PP 200 / AP 413
- Alloy 6060-T5
- 6000mm long
- 2.5mm wall thickness
- Patented friction legs for non-weld slat assembly
- Maximum slat insertion depth = 15mm
- lxx = 177.32 x 10E3 mmE4
- lyy = 176.23 x 10E3 mmE4

4x screw flutes in post allow tight fit of press in flat aluminium top plate. *Top plate sold separately*

Optional base plate can be attached using screw flutes for base plated post installations.

Finishes

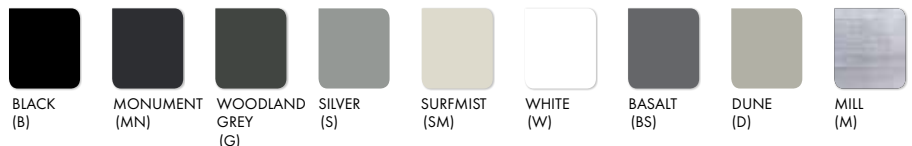

POST SYSTEM EXTRUSIONS



50x50mm full post

2400MM OR 6000MM LONG

Order Code: XP-2400/6000-FP

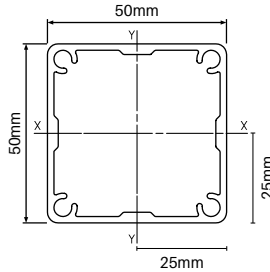

TECH SPECS

- PP 195 / AP 195
- Alloy 6063 - T6
- 1.8mm wall thickness with 3mm ribs
- Aluminium powder coated press-in top plate included with 2400mm posts
- lxx = 170.44 x 10E3 mmE4
- lyy = 170.44 x 10E3 mmE4

4x screw flutes in post allow tight fit of press in flat aluminium top plate.

Optional base plate can be attached using screw flutes for base plated post installations.

Finishes



Centre support rail

5800MM LONG

Order Code: XP-5800-CSR

OPTIONAL EXTRA

Commonly used for screens 2000mm or wider to provide strength & rigidity to panel

Snap-on cover hides fixings – provides slimline sturdy support rail with no visible fixings

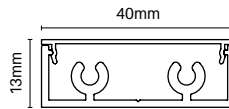

TECH SPECS

- PP 126 / AP 188
- Alloy 6063-T5
- 5800mm long
- Screw fix centre support rail to each slat
- Includes 2x screw flutes for press-in top cap
- Top cap sold separately
- lxx = 1.73 x 10E3 mmE4
- lyy = 26.34 x 10E3 mmE4

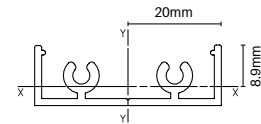

Finishes



2 PART CENTRE SUPPORT RAIL



Centre support rail cap

40mm x 13mm

3MM THICK

Order Code: XP-CSRC

- Nylon cap available in 5 colours
- Simply press into screw flutes in centre support rail
- Easy and fast fitting of cap

MATES WITH XP-5800-CSR

Finishes

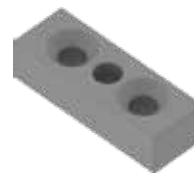

Centre support rail top/bottom plate

Order Code: XP-BTP

- Aluminium with countersunk hole machining
- 2x CSK screws included for fixing to CSR
- Optional extra to install with centre support rail
- Use to brace top and/or bottom of centre support rail to structure above or below if desired
- Bracing centre support rail provides extra rigidity to panels – recommended for wide screens
- Available in same colours as centre support rail

MATES WITH XP-5800-CSR



Screw top/bottom plate to centre support rail



Screw through central hole to substrate at top or bottom

SPACERS & EXTRAS



50 PACK Spacer blocks

5MM, 9MM OR
20MM SPACERS

Order Code: **XPL-SB-50PK-05MM**
XPL-SB-50PK-09MM
XPL-SB-50PK-20MM

- UV stabilised ASA thermoplastic - black
- Snaps into Xpress Plus post
- Provides 5mm, 9mm or 21mm space between slats
- Fast and easy install with post, slats and spacers

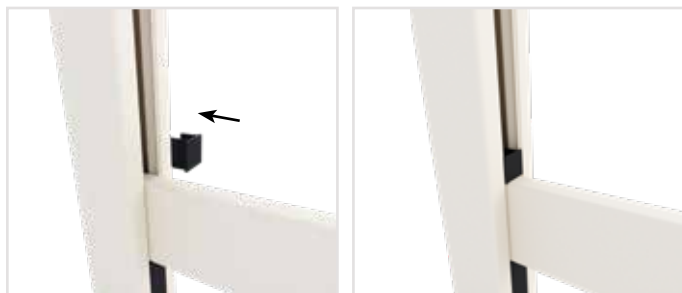

5 PACK Block

100MM or 1000MM LONG

Order Code: **XPL-BLOCK-5PK**
XPL-1000-BLOCK

- UV stabilised ABS - black
- Snaps into Xpress Plus post pocket
- Use to set starting height of first slat in post. Simply cut to starting height & snap into position at bottom of post
- Can also be cut to size to customise slat spacing



10 PACK Slat locking clip

Order Code: **XPL-SLATCLIP-10PK**

- Aluminium locking clip with SS304 self tapping screws
- Affix to both sides of top slat only between each fence post opening
- Acts as mechanical fix to prevent chance of posts splaying open
- Allow 5mm gap between top of final slat and top of post
- Locking clip hidden under post top plate



Self drilling wafer screws

10Gx16mm – BAG OF 100
Black / Monument / Woodland Grey / Silver / Surfmist / White Basalt / Dune / Mill finish

Order Code: **XP-SCREWS**

- Bags of 100 - 10G x 16mm self drilling wafer head zinc plated
- Colour matched powder coated heads
- Not required for post/slat assembly. Screws useful if needing to screw fix centre support rail to slat, U channel, angle or similar for an installation



Touch up paint

150g SPRAY CAN
Black / Monument / Woodland Grey / Silver / Surfmist / White Basalt / Dune

Order Code:
PAINT-B/MN/G/S/SM/W/BS/D

- Colour matched touch up paint
- Simply spray on for minor touch ups

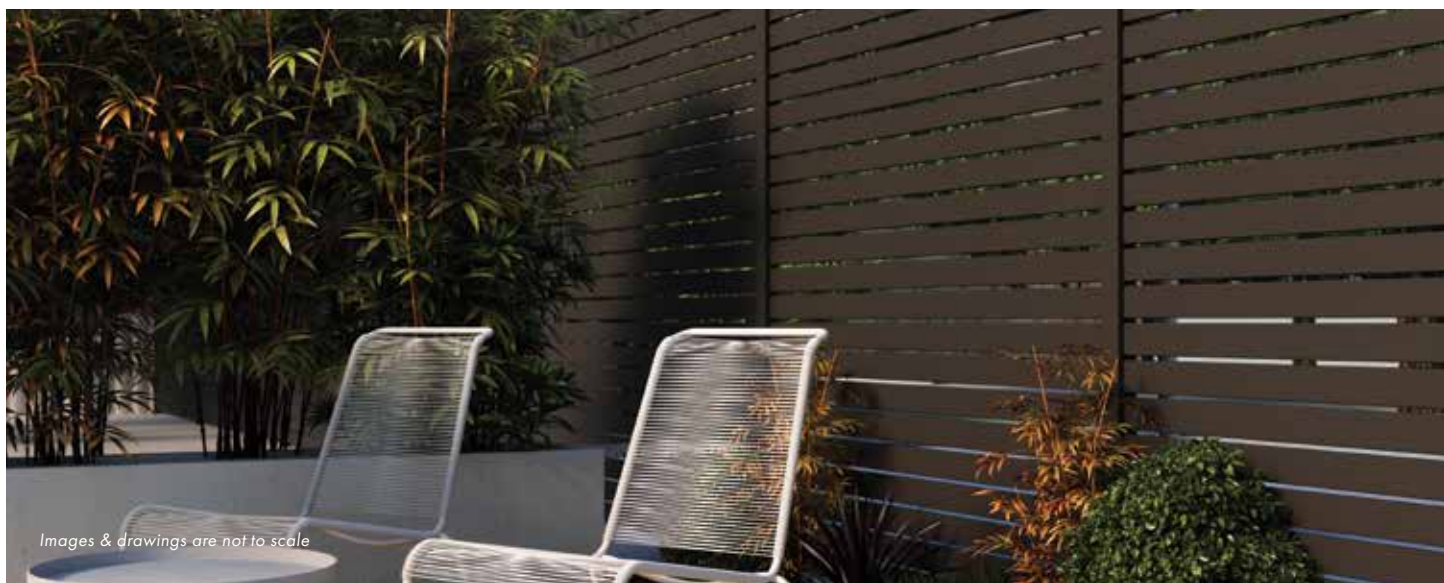

END PLATES & BASE PLATES



50x50mm post flat top plate

POWDER COATED ALUMINIUM
**Black / Monument / Woodland Grey
 Silver / Surfmist / White / Basalt
 Dune / Mill finish**

Order Code: XP-TP

- Alloy ADC12 aluminium plate - 3mm thick
- Press into post screw flutes for secure fixing
- Suits fitting to all 50x50mm Xpress Plus posts

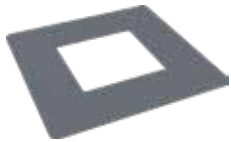
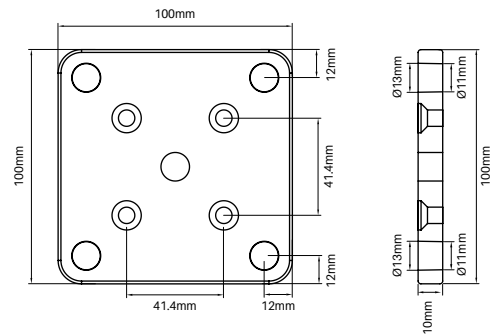
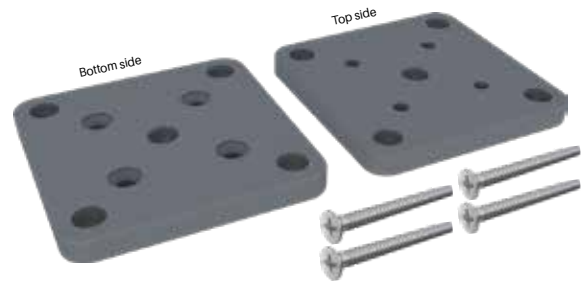

50x50mm post dress ring

POWDER COATED ALUMINIUM
**Black / Monument / Woodland Grey
 Silver / Surfmist / White / Basalt
 Dune / Mill finish**

Order Code: XP-DR

- Suits 50x50mm core drill posts
- 100mm x 100mm outer - 52mm x 52mm inner

50x50mm post base plate set

1x base plate & 4x screws

POWDER COATED ALUMINIUM
**Black / Monument / Woodland Grey / Silver
 Surfmist / White / Basalt / Dune / Mill finish**

Order Code: XP-BP-SET

- 100mm x 100mm base plate (10mm thick) with 4x fixing holes
- Simply screw base plate into core drill post screw flutes
- 4x 12G x 50mm long CSK screws (SS304) included in set

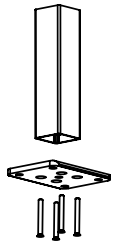

Discreet screws fix two parts of cover together

Two part domical cover

POWDER COATED ALUMINIUM
**Black / Monument / Woodland Grey
 Silver / Surfmist / White / Basalt
 Dune / Mill finish**

Order Code: XP-DC-2P

- Suits 50x50mm post with screw fixed base plate
- 106x106mm outer - 52x52mm inner - Alloy ADC12
- 30mm high
- Cover can be fitted to posts after fence is installed

Finishes



Timber fixing kit

4 PACK - SS316
 Order Code: S-110LAG-4PK

- M10 x 110mm timber lag screws x4 with nuts and washers
- Suits fixing holes in both the 50x50mm and 65x65mm base plate sets



Concrete fixing kit

4 PACK - SS316
 Order Code: S-120ROD-4PK

- M10 x 120mm concrete threaded rods x4 with nuts and washers
- Suits fixing holes in both the 50x50mm and 65x65mm base plate sets

POSTS & ACCESSORIES



65x65mm heavy duty post

2400MM or 6000MM LONG

Order Code: XP-2400/6000-65HD

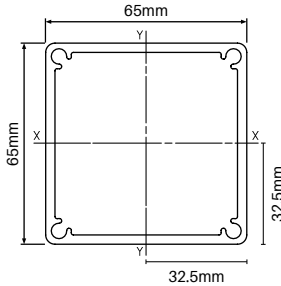

Finishes



TECH SPECS

- PP 255 / AP 255
- 65x65mm larger profile, heavy duty post
- Alloy 6063 - T6
- 3mm wall thickness
- Screw flutes to screw on base plate if required
- Aluminium powder coated press-in top plate included with 2400mm posts
- lxx = 464.62 x 10E3 mmE4
- lyy = 464.62 x 10E3 mmE4

4x screw flutes in post allow tight fit of press in flat aluminium top plate.

Optional base plate can be attached using screw flutes for base plated post installations.



65x65mm post flat top plate

POWDER COATED ALUMINIUM

Black / Monument / Woodland Grey / Silver / Surfmist
White / Basalt / Dune / Mill finish

Order Code: XP-65TP

- Alloy ADC12 aluminium plate - 3mm thick
- Press into post screw flutes for secure fixing
- 2400mm posts come with free top plate included - only purchase if extra top plates are required
- Top plates required for 6000mm posts - sold separately

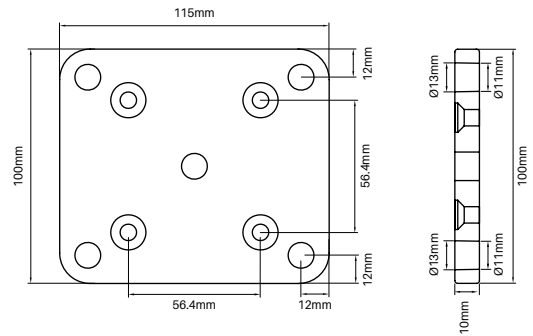

65x65mm post base plate set

1x base plate & 4x screws

POWDER COATED ALUMINIUM

Black / Monument / Woodland Grey / Silver
Surfmist / White / Basalt / Dune / Mill finish

Order Code: XP-65BP-SET

- 115mm x 100mm base plate (10mm thick) with 4x fixing holes
- Simply screw base plate into core drill post screw flutes
- 4x 12G x 50mm long CSK screws (SS304) included in set

Finishes

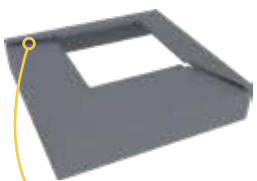

Discreet screws fix two parts of cover together

65x65mm two part domical cover

POWDER COATED ALUMINIUM

Black / Monument / Woodland Grey
Silver / Surfmist / White / Basalt
Dune / Mill finish

Order Code: XP-65DC-2P

- Suits 65x65mm post with screw fixed base plate
- 122x106mm outer - 67x67mm inner - Alloy ADC12
- 30mm high
- Cover can be fitted to posts after fence is installed

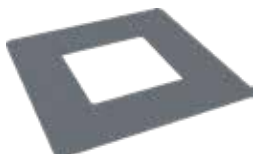

65x65mm post dress ring

POWDER COATED ALUMINIUM

Black / Monument / Woodland Grey / Silver / Surfmist
White / Basalt / Dune / Mill finish

Order Code: XP-65DR

- Suits 65x65mm heavy duty post
- 115mm x 115mm outer - 67mm x 67mm inner

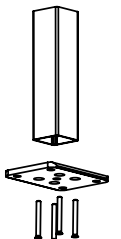

FENCING ACCESSORIES



Rapid set concrete

20KG BAG

Order Code: **GROUT-RSC**

- Specially formulated to harden rapidly
- Not available Perth depot – Use 20kg Kwik Set concrete (Code: GROUT-KWIKSET)

Concrete mix

20KG BAG

Order Code: **GROUT-CONCRETE**

- Quality blend of GP cement, aggregate & sand - just add water
 - Ideal for high strength concreting of posts
- Set concrete (Code: GROUT-KWIKSET)

Polaris grout

10KG BAG

Order Code: **GROUT-POL-10KG**

- Non shrink grout - rapid setting
- Aggregate free



Bostik HES grout

20KG BAG

Order Code: **GROUT-BOS**

- Non shrink structural grout
- High performance, high early strength

Sika HES grout

20KG BAG

Order Code: **GROUT-SIKA**

- Non shrink structural grout
- Ready mixed, high quality grout
- Sets with high early strength

UltraLoc Threadlocker 3242 compound

10ML BOTTLE

Order Code: **ULTRALOC-3242**

- Medium strength removable grade threadlocking compound for metal screws, nuts and fasteners from Ø6mm to Ø20mm

STAINLESS STEEL FASTENERS



M12 dome nut

PACK OF 4 – SS316

Order Code: **GS-DN-4PK**

• 4x dome nuts & 4x split washers

• Suits M12 thread

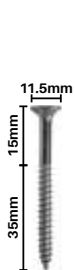

50mm CSK batten screw

SS316
14 gauge
Order Code: **CSK-050**



75mm CSK batten screw

SS316
14 gauge
Order Code: **CSK-075**

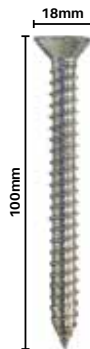

100mm CSK timber screw

4 PACK – SS316
M12 thread
Order Code: **CSK-100-4PK**

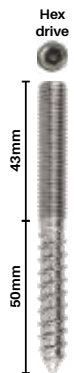

93mm lag screw

SS304
M12 thread
Order Code: **GS093LAG**

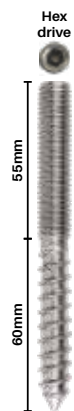

115mm lag screw

SS304
M12 thread
Order Code: **GS115LAG**



160mm lag screw

SS304
M12 thread
Order Code: **GS160LAG**

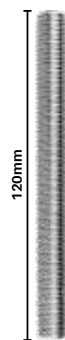

120mm threaded rod

SS304
M12 thread
Order Code: **GS120ROD**

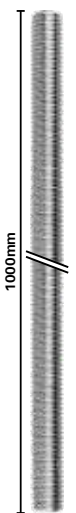

1000mm threaded rod

SS304
M12 thread
Order Code: **GS1000ROD**

DIAMOND REVOLUTION DRILL

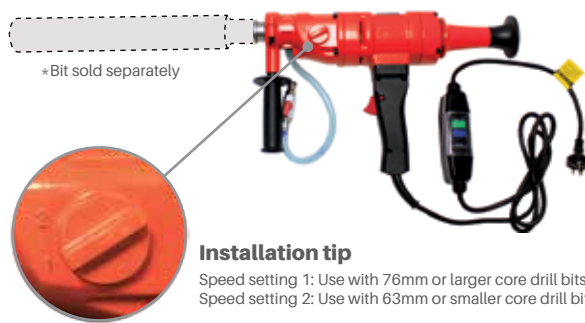

Diamond revolution drill

Core drill

Order Code: REV-CD-2S

- 2 speed core drill - 1500W
- Comes with case, allen key, spare set of brushes and manual
- Safety switch
- Uses common size 1 1/4" UNC male thread for diamond core bits

Technical data

Voltage: 240V

Rated frequency: 50-60Hz

Rated input power: 1500W

No load speed r/min: 2100/950

Weight: 8.8kg

Diamond revolution stand

Suits diamond revolution core drill

Order Code: REV-STAND

- Steel and aluminium construction
- Height: 800mm
- Base: 330mm x 380mm
- Weight: 12.6kg



Core drill template

Order Code: REV-TEMPLATE

- Assists with starting to core drill hole
- Stabilises the drill bit from jumping



Spirit level for core drill

Order Code: REV-LEVEL

- Screws into core drill machine
- Assists with drilling accurate holes



Splash guard/ water trap

Order Code: REV-GUARD



Base for stand

Order Code: REV-BASE

- 550mm x 550mm overall dimensions

Core drill bits

Mild steel body & diamond impregnated crown tip



8mm mini core drill bit

Order Code: REV-BIT-08



10mm mini core drill bit

Order Code: REV-BIT-10



12mm mini core drill bit

Order Code: REV-BIT-12



14mm mini core drill bit

Order Code: REV-BIT-14



20mm mini core drill bit

Order Code: REV-BIT-20



53mm core drill bit

53mm x 450mm long
Order Code: REV-BIT-53



63mm core drill bit

63mm x 450mm long
Order Code: REV-BIT-63



76mm core drill bit

76mm x 450mm long
Order Code: REV-BIT-76



83mm core drill bit

83mm x 450mm long
Order Code: REV-BIT-83



89mm core drill bit

89mm x 450mm long
Order Code: REV-BIT-89

POST INSTALL OVERVIEW



1 Determine fence layout



2 Determine how posts are to be installed:

1. Core drill into concrete (recommended min. Ø76mm core hole at approx. 100mm deep)

2. Base plated to surface (base plates can be screw fixed to posts)

3. Set into ground with concrete footings (recommended footings min 600mm deep x 300mm wide with post embedded to 600mm minimum and then concrete filled)

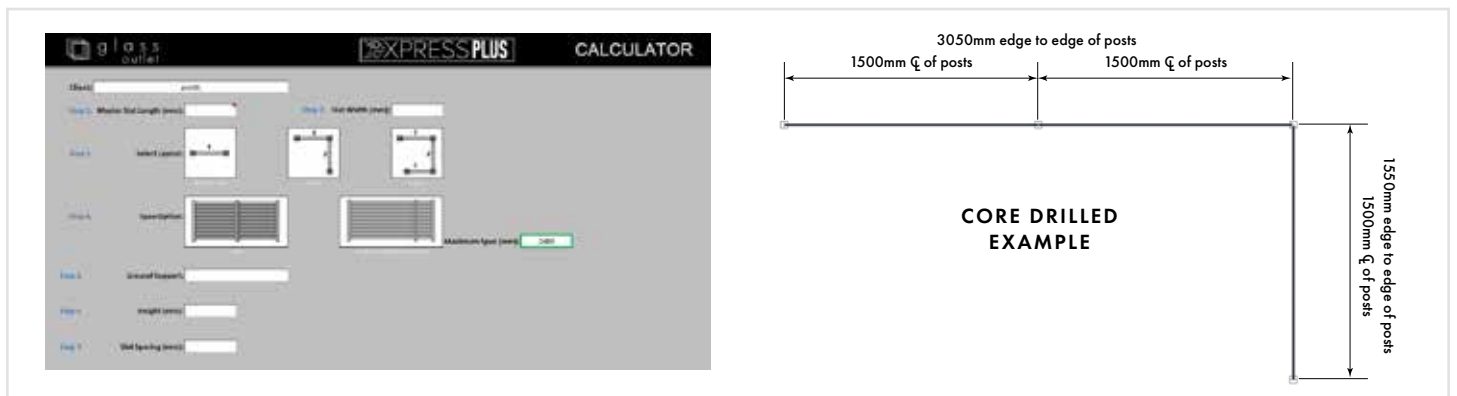

3 Determine post positions

For simplicity, calculate post positions from centre of post to centre of post.

Refer Xpress Plus calculator which provides post centres depending on layout selected.

*Recommended that post centres do not exceed 2500mm. In areas of high wind, consider restricting span widths.

Install tip: For end or corner posts of a run, there will be 25mm extra to take into account for 'overhang' of 50mm post.

For base plated installs, end or corner posts have an extra 50mm 'overhang' with the post and base plate.

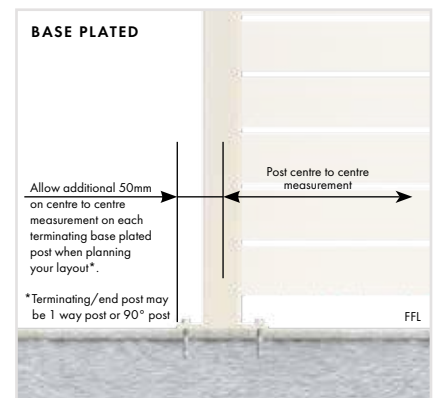
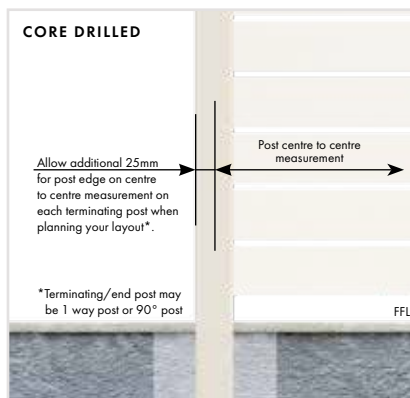

POST INSTALL OVERVIEW

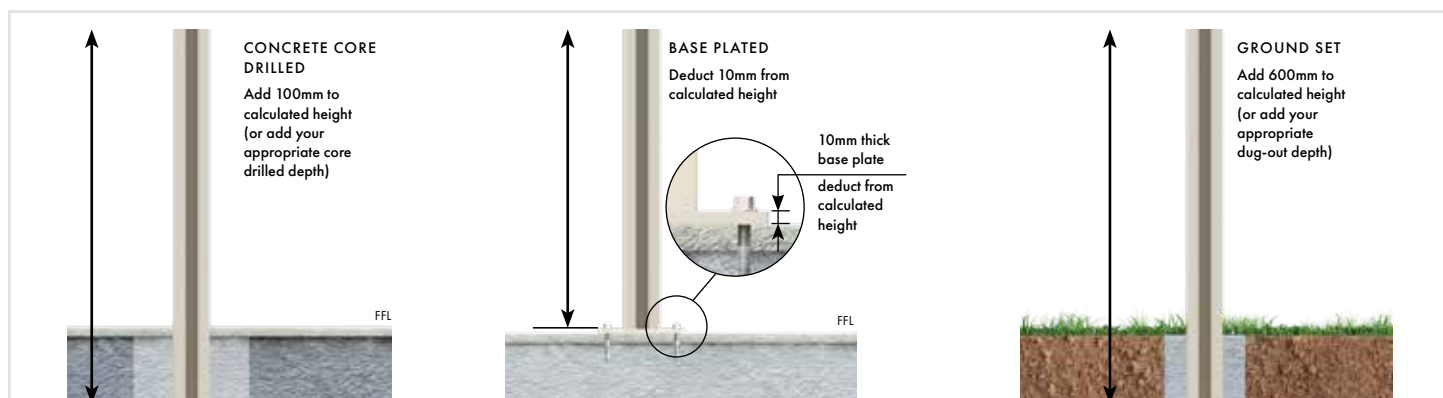

4 Determine overall post height required

The Xpress Plus excel calculator calculates requirements from ground level upwards.

For overall post heights required, add the extra length below the surface for core drill and concrete footings.

For base plated installations, deduct 10mm from screen height (as base plate is 10mm thick)

Install posts.

TIP - Use spirit level to ensure posts are vertically level. Ensure top of posts level and in alignment.

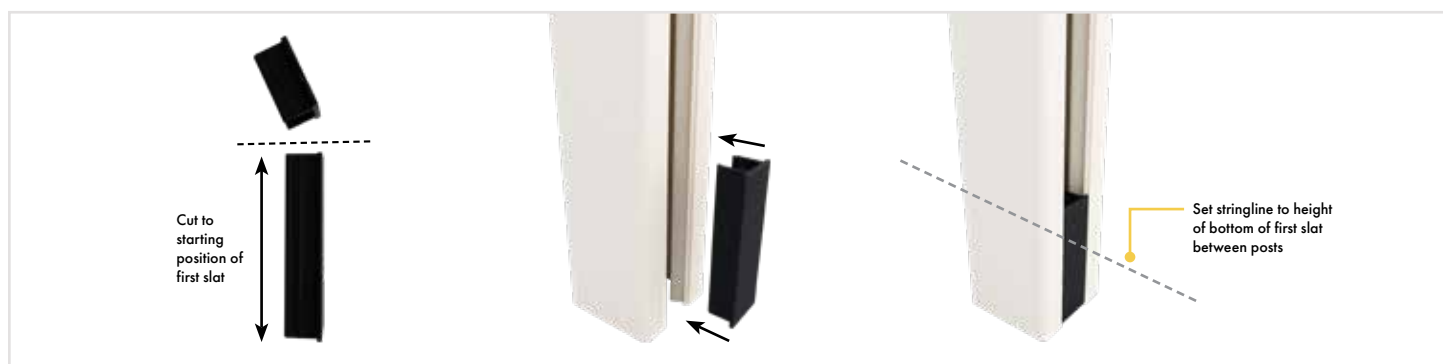

5 Xpress Plus calculator provides calculation of height to cut initial height setting blocks.

NOTE: For uneven ground/deck, cut one setting block only and place at the highest point of the finished floor line. Then, run a level string line to determine heights of remaining setting blocks before cutting to size.

TIP - it is recommended that the bottom gap is no higher than 50mm. Consider lowering or raising overall post height to achieve a starting gap less than 50mm.

Cut setting blocks to suit stringline level and snap into posts.

Use stringline to set first slat height.

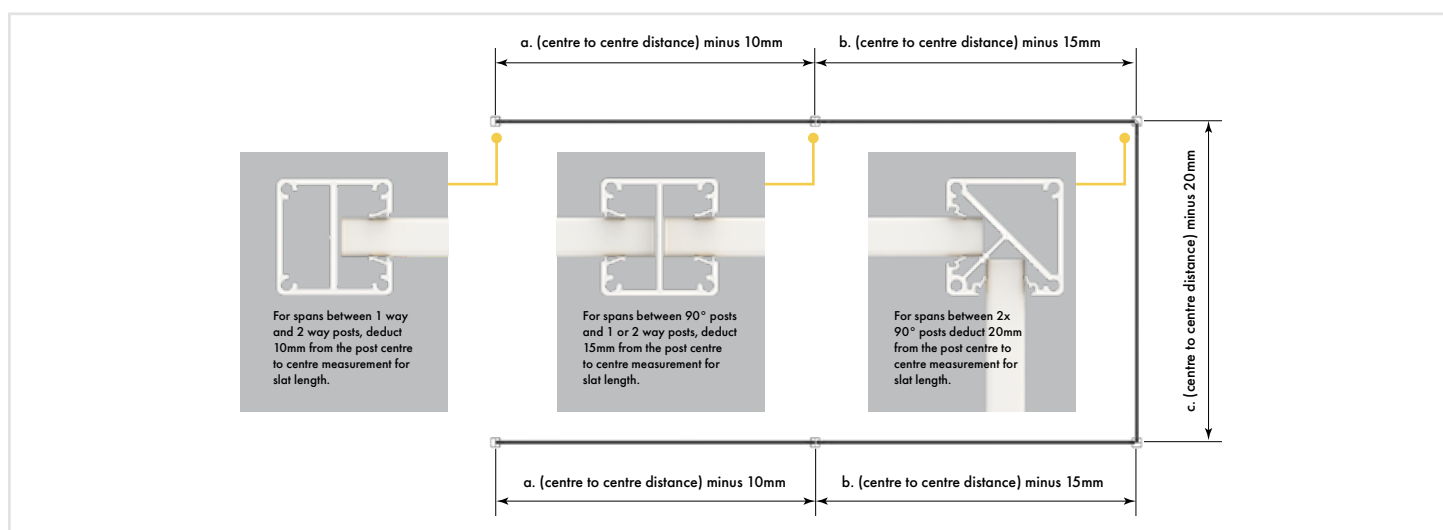

6 Cut slats to appropriate length for each post opening - Refer Xpress Plus excel calculator for guide on slat lengths required.

Deduction summary:

a. For spans between any 1 way post and 2 way post combination, slats are cut **10mm less** than the centre to centre of posts

b. For spans leading into a 90 degree post, slats are cut **15mm less** than the centre to centre of posts

c. For spans between two 90 degree posts, slats are cut **20mm less** than the centre to centre of posts

POST INSTALL OVERVIEW

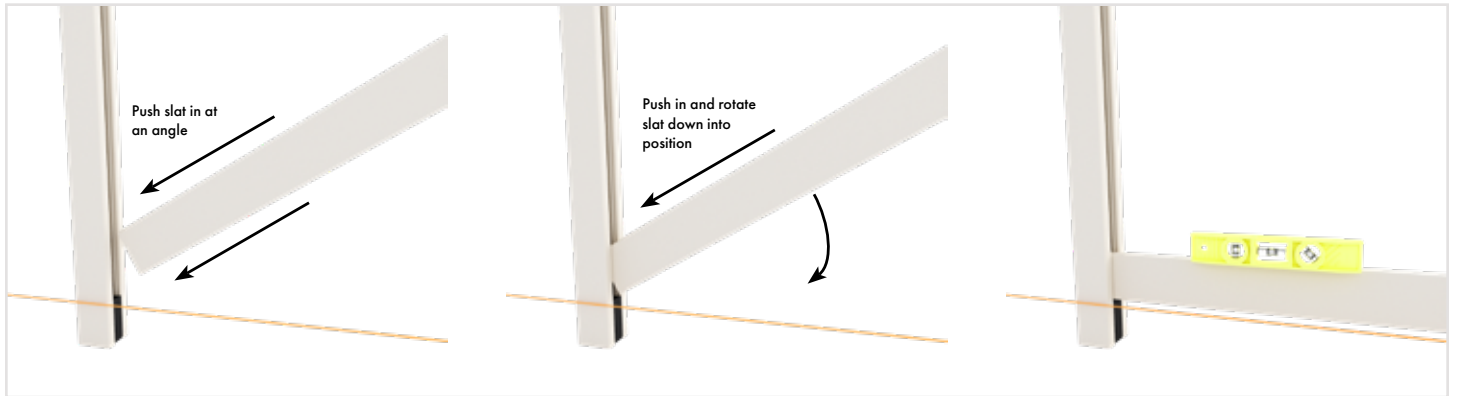

- 7 Install first slat in each span. Using spirit level, ensure slats are level.



- 8 Snap in spacer block above first slat into either side of pocket of post. Repeat for all slats.

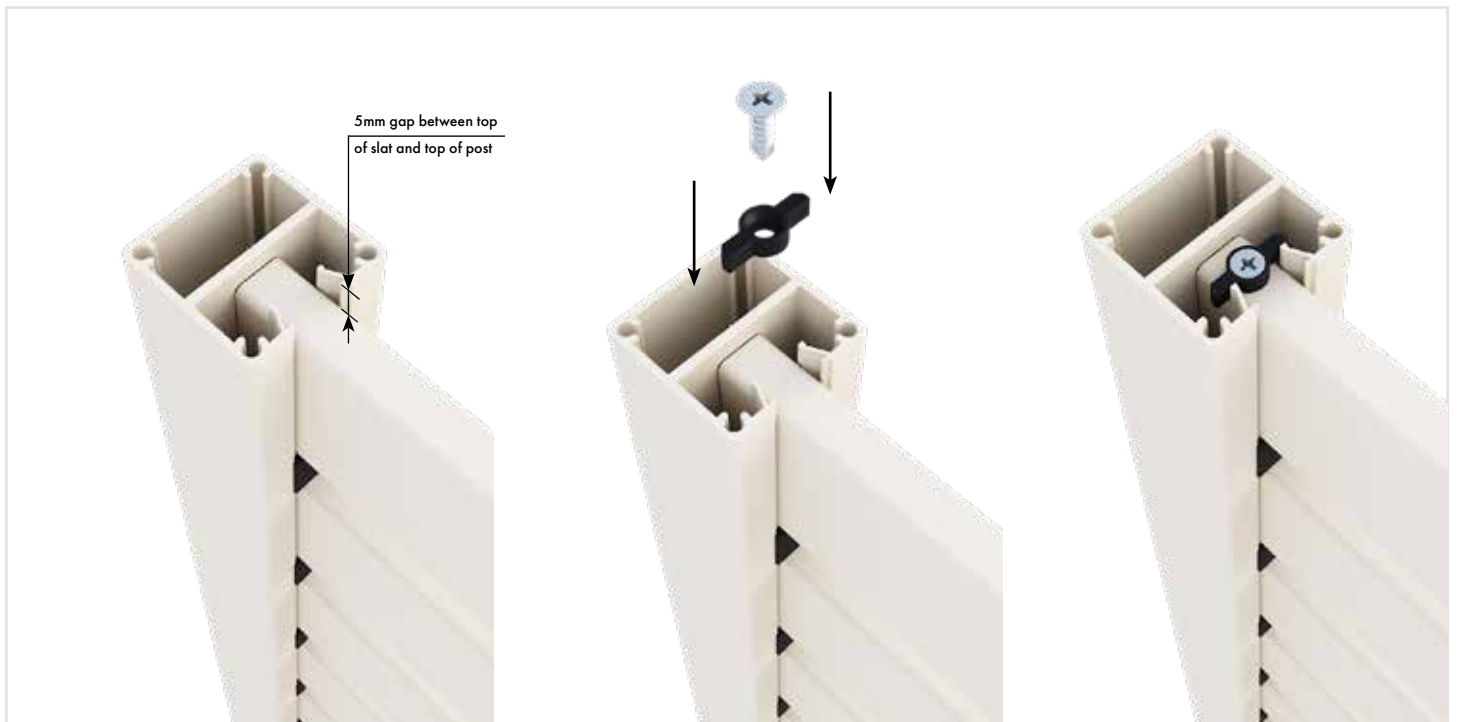

- 9 Top slat finishes 5mm below the top of the post. Screw slat locking clip into top slat.

POST INSTALL OVERVIEW



10 Install 3mm thick top plate. Use rubber mallet to tap into position.

OPTIONAL
EXTRA:
**Centre
support
rail**

See page 46 for full
specifications



11 **Install note: for spans over 2000mm (or in high wind areas under 2000mm wide) it is recommended to have a centre support rail**
Place centre support rail against slats and screw off at each slat using XP-SCREWS. Snap on fixing cover to hide screws.



innovative, non-weld Pedestrian gates

AVAILABLE IN 2 CONVENIENT SUPPLY OPTIONS

1

Long length supply

Buy long length extrusions then cut to size and assemble on-site or at your premises

2

Cut to size service

Simply provide gate size required – we will cut to size and flat pack for easy assembly



Pedestrian gate options

SELECT FROM A RANGE OF PEDESTRIAN GATE OPTIONS

We can cut to size, flat pack and send Australia wide or you can purchase long length extrusions and cut to size yourself.

Assemble pre-powder coated gates with no welding or riveting required.

Save time and money without requirement of fully fabricating and welding gates.

Contact us for detailed assembly instructions



1 Horizontal slat pedestrian gate

Fitted with D&D Lokk Latch Deluxe

65mm x 16.5mm slats with 9mm or 20mm slat spacing

Patented gate side frames for fast assembly



2 Horizontal slat pedestrian gate

Fitted with D&D Lokk Latch Deluxe

65mm x 16.5mm or 90mm x 16.5mm slats

Variable slat spacing

Each slat required to be screw fixed



3 Horizontal slat pedestrian gate

Fitted with Lockwood 001 deadlatch

65mm x 16.5mm slats with 9mm or 20mm slat spacing

Patented gate side frames for fast assembly

Patented non-weld lockbox



4 Horizontal slat pedestrian gate

Fitted with knob or lever handle

65mm x 16.5mm slats with 9mm or 20mm slat spacing

Patented gate side frames for fast assembly

Patented non-weld lockbox



5 Vertical slat pedestrian gate

Fitted with D&D Lokk Latch Deluxe

65mm x 16.5mm or 90mm x 16.5mm slats

Variable slat spacing

Each slat required to be screw fixed

PEDESTRIAN GATE OPTIONS

Option 1

Horizontal slot gate with 65mm x 16.5mm slats
9mm or 20mm slot spacing
Fitted with the D&D LOKK Latch Deluxe

SEE PAGES 64-71 FOR FULL SPECIFICATIONS ON ALL PRODUCTS LISTED BELOW

- 1 **Patented non-weld gate side frames**
Machined drill holes & slots – 9mm or 20mm spacing
Suits 65x16.5mm slat
XP-4200-GSF09 or XP-4200-GSF20
- 2 **Gate insert**
Snaps into gate side frame to hide gate slat fixing screws
XP-4200-GI
- 3 **Gate frame cap**
Simply press into top of gate frames
XP-GFC
- 4 **Gate frame screws**
12 gauge x 65mm long with flange hex head
XP-SCREWSGF-10PK
- 5 **Gate hinges**
A range of hinging options available
See pages 72-76 & 82-83 for hinge options
- 6 **65mm x 16.5mm gate slat w/ 2x screw flutes**
Screw fluted slats at top/middle/bottom of gate
XP-6100-GB65
- 7 **65x16.5mm slat**
Standard slats held in place with patented friction fitting gate side frame
XP-6100-S65
- 8 **Lokk Latch Deluxe**
Manufactured by D&D Technologies
Lockable both sides
LL-DL | See pages 77-78 & 84



! INFORMATION BELOW RELATES TO OPTION 1 ONLY

GATE CONFIGURATIONS 'Gate slat' positioning in conjunction with width & height specifications

Up to 1000mm wide



Gate blades:

- 2x top
- 1x middle
- 1x bottom

From 1001mm to 1200mm wide



Gate blades:

- 2x top
- 1x middle
- 2x bottom

PEDESTRIAN GATE OPTIONS

Option 2

Horizontal slat gate with 65mm or 90mm x 16.5mm slats
Variable slat spacing including nil spacing
Fitted with the D&D Lokk Latch Deluxe
Maximum 1200mm wide

SEE PAGES 64-71 FOR FULL SPECIFICATIONS ON ALL PRODUCTS LISTED BELOW

- 1 **Patented non-weld gate side frames**
Machined drill holes
XP-4200-GSF20
- 2 **Gate insert**
Snaps into gate side frame to hide required fixing screws
XP-4200-GI
- 3 **Gate frame cap**
Simply press into top of gate frames
XP-GFC
- 4 **Gate frame screws**
12 gauge x 65mm long with flange hex head
Use to fix off heavy duty top/bottom rail
XP-SCREWSGF-10PK
- 5 **Gate hinges**
A range of hinging options available
See pages 72-76 & 82-83 for hinge options
- 6 **Non-punched gate infill**
Replaces slotted infill from gate side frame
XP-XBAT-4200-INF
- 7 **Quickscreen sideframe**
Affix to inner face of gate side frame
Insert and screw off each slat – variable spacing
QS-5800-SF
- 8 **Quickscreen concealed fixing cover**
Snap-on cover to hide slat fixing screws
QS-5800-CFC
- 9 **Fixing screws**
Use to affix Quickscreen side frames and slats
All slats must be screw fixed to side frames
XP-SCREWS
- 10 **65x16.5mm or 90x16.5mm slat**
Slats held in place with fixing screws
XP-6100-S65 / QS-6100-S90



- 11 **65x45mm heavy duty rail**
Position at top & bottom of gate
XP-6100-HD6545

- 12 **Lokk Latch Deluxe w/ packer**
Manufactured by D&D Technologies
Lockable both sides
LL-DL | See page 77-78 & 84

! INFORMATION BELOW RELATES TO OPTION 1 ONLY

From 1201 mm to 1500mm wide



- Gate blades:**
- 3x top
 - 1x middle
 - 2x bottom

From 1501 mm to 2100mm wide

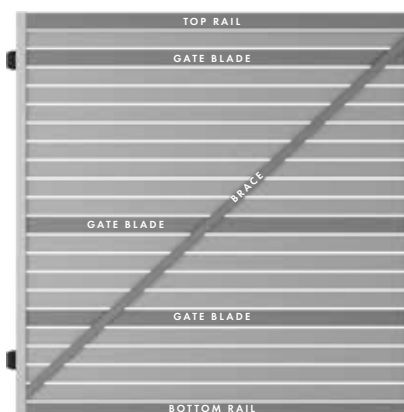

- Gate blades:**
- 1x 2nd slat down
 - 1x middle
 - 1x ¾ down

- Top & bottom rail:**
- 1x HD top rail
 - 1x HD bottom rail

- Brace:**
- 1x centre support rail (Diagonal)

PEDESTRIAN GATE OPTIONS

Option 3

Horizontal slat gate with 65mm x 16.5mm slats
9mm or 20mm slat spacing
Fitted with the Lockwood 001 deadlatch
*Inwards swinging only

SEE PAGES 64-71 FOR FULL SPECIFICATIONS ON ALL PRODUCTS LISTED BELOW

- 1 **Patented non-weld gate side frames**
Machined drill holes & slots – 9mm or 20mm spacing
Suits 65x16.5mm slat
XP-4200-GSF09 or XP-4200-GSF20
- 2 **Gate insert**
Snaps into gate side frame to hide gate slat fixing screws
XP-4200-GI
- 3 **Gate stop & rubber**
Required for latch side of gate
XP-4200-GSTOP / XP-GATESTOP-RUB
- 4 **Aluminium CSK blind rivet**
CSK rivets recommended due to 3mm gap between latching post & gate side frame
XP-GATESTOP-RIV-10PK
- 5 **Gate frame cap**
Simply press into top of gate frames
XP-GFC
- 6 **Gate frame screws**
12 gauge x 65mm long with flange hex head
XP-SCREWSGF-10PK
- 7 **Gate hinges**
A range of hinging options available
See pages 72-76 & 82-83 for hinge options
- 8 **65mm x 16.5mm gate slat w/ 2x screw flutes**
Screw fluted slats at top/middle/bottom of gate
XP-6100-GB65
- 9 **65x16.5mm slat**
Standard slats held in place with patented friction fitting gate side frame
XP-6100-S65



- 10 **Deadlatch lockbox**
Patented non-weld lockbox to suit Lockwood 001 deadlatch
XP-LBOX-DL

- 11 **Lockwood 001 deadlatch**
Manufactured by Lockwood
XP-DL001 | See page 68

! INFORMATION BELOW RELATES TO OPTIONS 3 & 4

GATE CONFIGURATIONS 'Gate slat' positioning in conjunction with width & height specifications

Up to 1000mm wide



Gate blades:

- 2x top
- 1x middle
- 1x bottom

From 1001mm to 1200mm wide



Gate blades:

- 2x top
- 1x middle
- 2x bottom

PEDESTRIAN GATE OPTIONS

Option 4

Horizontal slat gate with 65mm x 16.5mm slats
9mm or 20mm slat spacing
Fitted with knob or lever handle set

SEE PAGES 64-71 FOR FULL SPECIFICATIONS ON ALL PRODUCTS LISTED BELOW

1 Gate lever set lock box kit

Inclusions:

- 1a 2x 2094mm gate side frame (9mm or 20mm spacing)
 - 1b 2x Gate insert
 - 1c 2x Machined gate stop (Left & right) with bulb rubber
 - 1d 1x Non-machined gate stop (for hinge side)
 - 1e 2x Gate frame caps
 - 1f 1x 10 pack Wafer head 10-16x16mm screws (For affixing gate stop)
- XP-GKIT-LSET09 or XP-GKIT-LSET20

2 Gate frame screws

12 gauge x 65mm long with flange hex head
XP-SCREWSGF-10PK

3 Gate hinges

A range of hinging options available
See pages 72-76 & 82-83 for hinge options

4 65mm x 16.5mm gate slat w/ 2x screw flutes

Screw fluted slats at top/middle/bottom of gate
XP-6100-GB65

5 65x16.5mm slat

Standard slats held in place with patented friction fitting gate side frame
XP-6100-S65

6 Lockbox

Patented non-weld lockbox to suit knob/lever handle set
XP-LBOX-LSET

7 Knob or lever handle set

Key lockable both sides
XP-HDL-KNOB / XP-HDL-LEVER / XP-HDL-LW534
See page 68



! INFORMATION BELOW RELATES TO OPTIONS 3 & 4

From 1201 mm to 1500mm wide



Gate blades:

- 3x top
- 1x middle
- 2x bottom

From 1501 mm to 2100mm wide

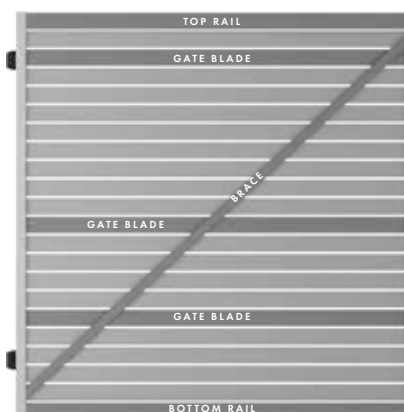

Gate blades:

- 1x 2nd slat down
- 1x middle
- 1x ¾ down

Top & bottom rail:

- 1x HD top rail
- 1x HD bottom rail

Brace:

- 1x centre support rail (Diagonal)

PEDESTRIAN GATE OPTIONS

Option 5

Vertical slat gate with 65mm or 90mm x 16.5mm slats
Variable slat spacing including nil spacing
Fitted with the D&D Lokk Latch Deluxe
Maximum 1200mm wide

SEE PAGES 64-71 FOR FULL SPECIFICATIONS ON ALL PRODUCTS LISTED BELOW

- 1 **Patented non-weld gate side frames**
Machined drill holes
XP-4200-GSF20
- 2 **Gate insert**
Snaps into gate side frame to hide top & bottom rail fixing screws
XP-4200-GI
- 3 **Gate frame cap**
Simply press into top of gate frames
XP-GFC
- 4 **Gate frame screws**
12 gauge x 65mm long with flange hex head
Use to fix off heavy duty top/bottom rail
XP-SCREWSGF-10PK
- 5 **Gate hinges**
A range of hinging options available
See pages 72-76 & 82-83 for hinge options
- 6 **Non-punched gate infill**
Replaces slotted infill from gate side frame
XP-XBAT-4200-INF
- 7 **U channel**
Affix to vertical inner face of gate side frames
Reduces potential light gap on both vertical edges of gate
QS-5000-HORIZ
- 8 **Quickscreen sideframe**
Affix to inner face of top & bottom rails
Insert and screw off each slat – variable spacing
QS-5800-SF
- 9 **Quickscreen concealed fixing cover**
Snap-on cover to hide slat fixing screws
QS-5800-CFC
- 10 **Fixing screws**
Use to affix Quickscreen side frames and slats
All slats must be screw fixed to side frames
XP-SCREWS
- 11 **65x45mm heavy duty rail**
Position at top & bottom of gate
XP-6100-HD6545
- 12 **65x16.5mm or 90x16.5mm slat**
Slats held in place with fixing screws
XP-6100-S65 / QS-6100-S90
- 13 **Lokk Latch Deluxe w/ packer**
Manufactured by D&D Technologies
Lockable both sides
LL-DL | See page 77-78 & 84

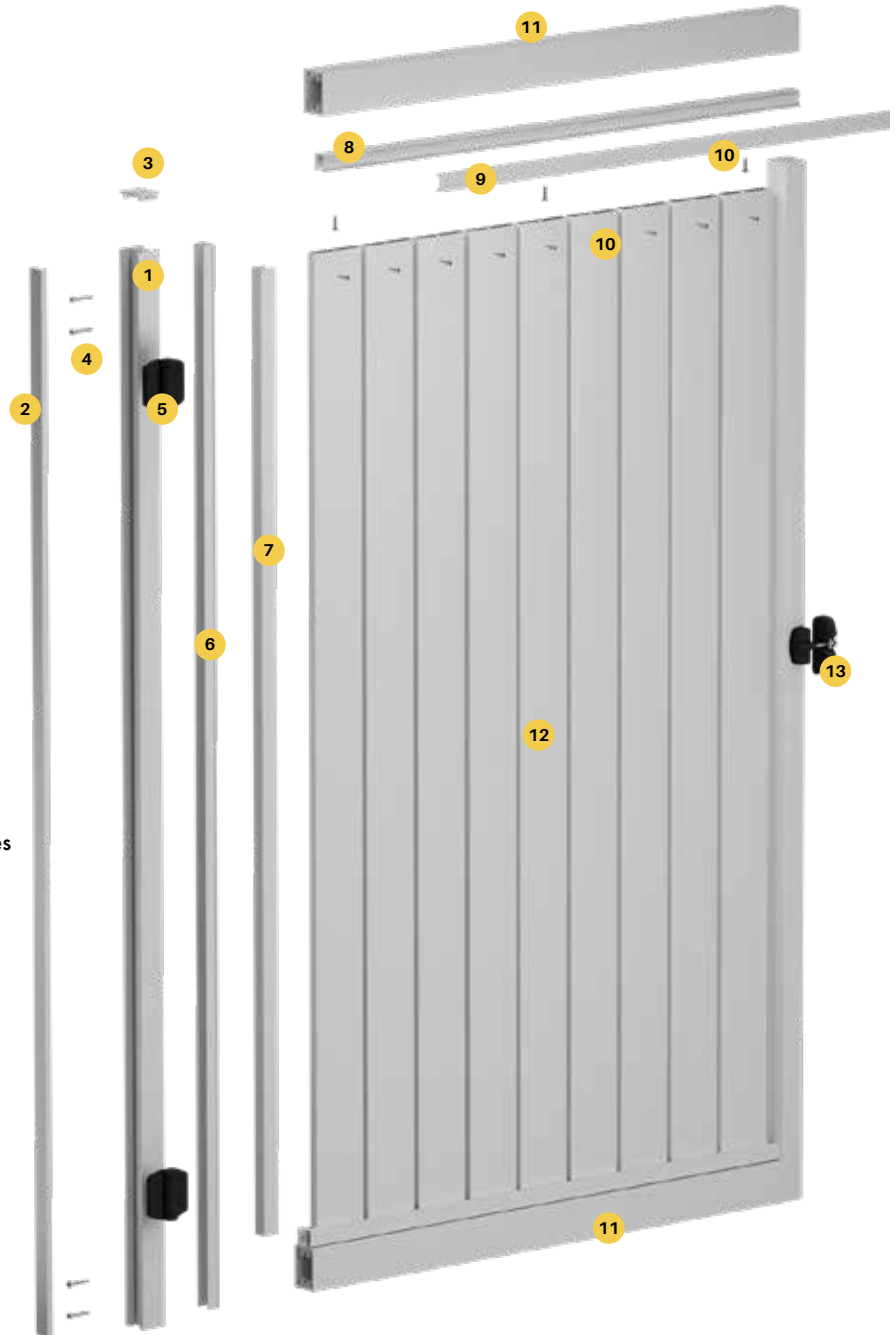

When calculating even spacing between vertical slats, overall gate width should be carefully considered to ensure first and last gap (between gate side frames and first/last slat) are kept uniform with other slat spacing



GATE EXTRUSIONS



PATENTED FRICTION FIT SYSTEM

9MM SPACING Slotted gate side frame

4200MM LONG

Order Code: XP-4200-GSF09

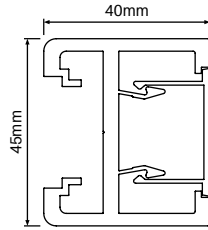

Finishes

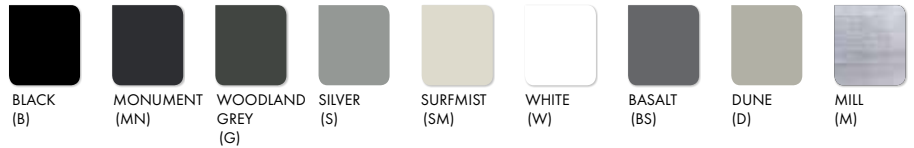

TECH SPECS

- PP 170
- Alloy 6063-T5 / 4200mm long
- 3mm wall thickness with 3.8mm centre crossmember
- Slotted insert to suit 65x16.5mm slat with 9mm spacing
- Patented frame for friction insertion of slats
- Crossmember machined with drill holes along entire length to suit screw fixing of strategically placed 'gate slats' featuring screw flutes
- lxx = 6.294 x 10E3 mmE4
- lyy = 152.403 x 10E3 mmE4

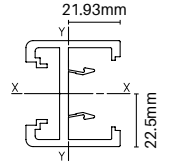

PATENTED FRICTION FIT SYSTEM

20MM SPACING Slotted gate side frame

4200MM LONG

Order Code: XP-4200-GSF20

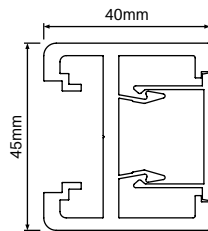

Finishes



TECH SPECS

- PP 170
- Alloy 6063-T5 / 4200mm long
- 3mm wall thickness with 3.8mm centre crossmember
- Slotted insert to suit 65x16.5mm slat with 20mm spacing
- Patented frame for friction insertion of slats
- Crossmember machined with drill holes along entire length to suit screw fixing of strategically placed 'gate slats' featuring screw flutes
- lxx = 6.294 x 10E3 mmE4
- lyy = 152.403 x 10E3 mmE4

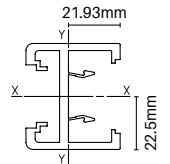

Snap-in gate insert

4200MM LONG

Order Code: XP-4200-GI

MATES WITH XP-4200-GSF09/20

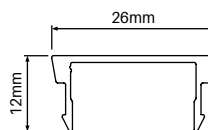

Finishes



TECH SPECS

- PP 100 / AP 100
- Alloy 6060-T5 / 4200mm long
- Snap-in gate insert mates with gate side frame
- Hides screws required for fixing 'gate slats' into position
- lxx = 0.86 x 10E3 mmE4
- lyy = 5.93 x 10E3 mmE4

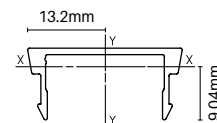

GATE EXTRUSIONS



NON-PUNCHED Gate infill

4200MM LONG

Order Code: **XP-XBAT-4200-INF**

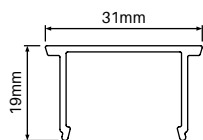

TECH SPECS

- PP 100 / AP 133
- Alloy 6060-T5 / 4200mm long
- Non-punched snap-in infill for gate side frames
- Required when making vertical gates, variable spaced horizontal slat gates or gates using 90mm x 16.5mm slats
- Replace existing slotted infill in gate side frame with non-punched gate infill
- lxx = 2.94 x 10E3 mmE4
- lyy = 9.50 x 10E3 mmE4

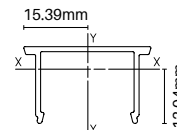

Finishes

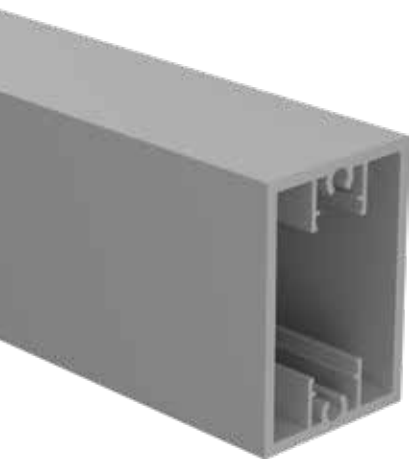

Heavy duty top/bottom rail

6100MM LONG

Order Code: **XP-6100-HD6545**

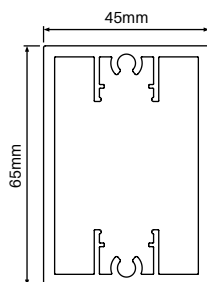

TECH SPECS

- PP 219 / AP 219
- Alloy 6063-T5 / 6100mm long
- 3mm wall thickness
- Heavy duty top/bottom rail used for wide gates
- Also required for vertical slat gates, horizontal gates with variable spacing or gates fitted with a lockbox
- Non weld assembly using 12 gauge screws into screw flutes (Code: XP-SCREWSGF-10PK)
- lxx = 206.98 x 10E3 mmE4
- lyy = 427.32 x 10E3 mmE4

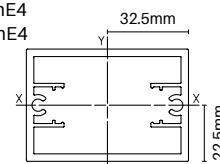

Finishes



65mm x 16.5mm gate slat with centre web & 2x screw flutes

6100MM LONG

Order Code: **XP-6100-GB65**

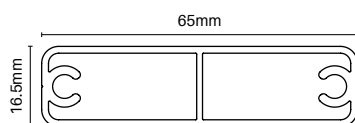

TECH SPECS

- PP 158 / AP 158
- Alloy 6063-T6
- 6100mm long
- 1.5mm wall thickness with 1.2mm wall centre web
- 2x screw flutes
- Used in strategic positions for pedestrian gate assembly
- Non weld assembly using 12 gauge screws into screw flutes (Code: XP-SCREWSGF-10PK)
- lxx = 11.85 x 10E3 mmE4
- lyy = 144.09 x 10E3 mmE4

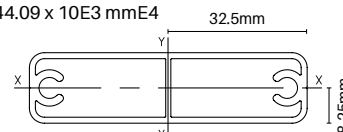

Finishes

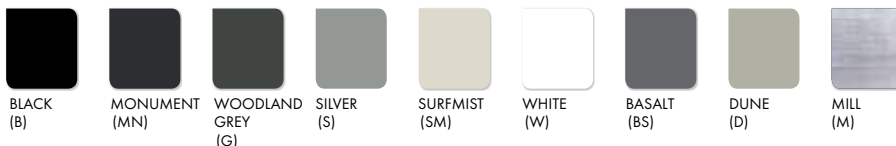

STANDARD SLATS ALSO REQUIRED FOR GATE ASSEMBLY
SEE PAGE 6 FOR SLAT OPTIONS

GATE EXTRUSIONS



Quickscreen side frame

5800MM LONG
Order Code: QS-5800-SF

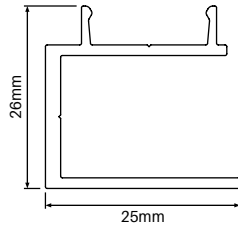

TECH SPECS

- PP 104 / AP 156
- Alloy 6063-T6 / 5800mm long
- Used for gates with horizontal variable slat spacing and vertical slat gates
- Each slat must be screw fixed to side frame
- Affix side frame to 45mm x 40mm gate frame
- lxx = 9.58 x 10E3 mmE4
- lyy = 8.38 x 10E3 mmE4

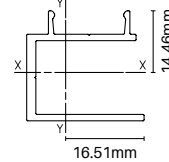

Finishes

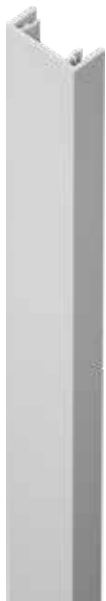

Quickscreen concealed fixing cover

5800MM LONG
Order Code: QS-5800-CFC

MATES WITH QS-5800-SF

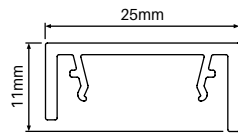

TECH SPECS

- PP 100 / AP 116
- Alloy 6060-T5 / 5800mm long
- Snap-on cover for Quickscreen side frame
- Hides screws used to affix slats to side frame
- lxx = 0.71 x 10E3 mmE4
- lyy = 6.58 x 10E3 mmE4

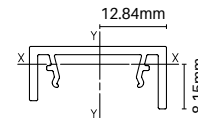

Finishes

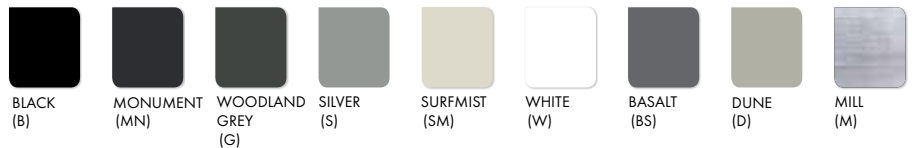

Gate stop

4200MM LONG
Order Code: XP-4200-GSTOP

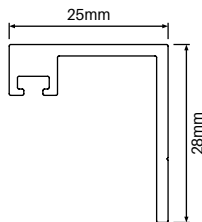

TECH SPECS

- PP 106 / AP 123
- Alloy 6063-T5 / 4200mm long
- Must be used on gates fitted with Lockwood 001 lockbox
- Bulb rubber sold separately (Code: XP-GATESTOP-RUB)
- lxx = 7.61 x 10E3 mmE4
- lyy = 10.95 x 10E3 mmE4

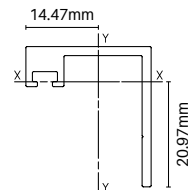

Finishes



GATE EXTRUSIONS



Heavy duty U channel

5000MM LONG

Order Code: QS-5000-HORIZ

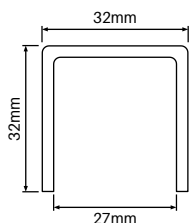

TECH SPECS

- PP 184 / AP 184
- Alloy 6060-T5
- 5000mm long
- 2.5mm wall thickness
- Required for vertical slat pedestrian gates only. Use on both internal vertical sides to reduce light gaps at gate edges
- lxx = 23.97 x 10E3 mmE4
- lyy = 38.92 x 10E3 mmE4

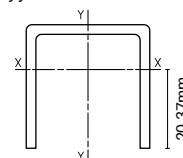

Finishes

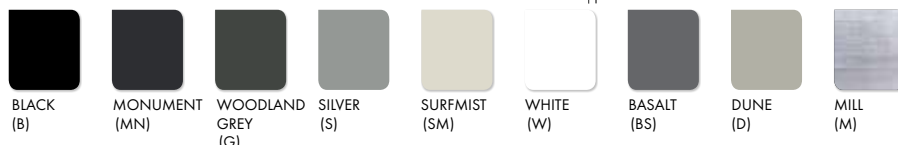

9mm gate lockbox kit

SUITABLE FOR LEVER/KNOB LOCK SET

Order Code: XP-GKIT-LSET09

- Gate side frame kit is specifically machined to suit horizontal pedestrian gate with lockbox and KNOB/LEVER set
- Patented non-weld assembly system: Use pre-powder coated aluminium lockbox (Code: XP-LBOX-LSET)
- Suits 65x16mm slats with 9mm spacing (Sold separately)
- Lockbox and lever/knob handle sold separately

KIT INCLUSIONS

- 2 x 2094mm long Gate Side Frame slotted with 9mm space (1pc has extra machining for lock set)
- 2 x 2094mm long Gate Inserts
- 1 x 2200mm long Right hand machined Gate Stop
- 1 x 2200mm long Left hand machined Gate Stop
- 1 x 2200mm long non-machined Gate Stop (for hinge side)
- 2 x 2250mm long Gate Stop Rubber
- 2 x Gate Frame Cap - Black nylon
- 1 x 10 pack Wafer head 10-16 x 16mm screws (for affixing gate stop)

Finishes

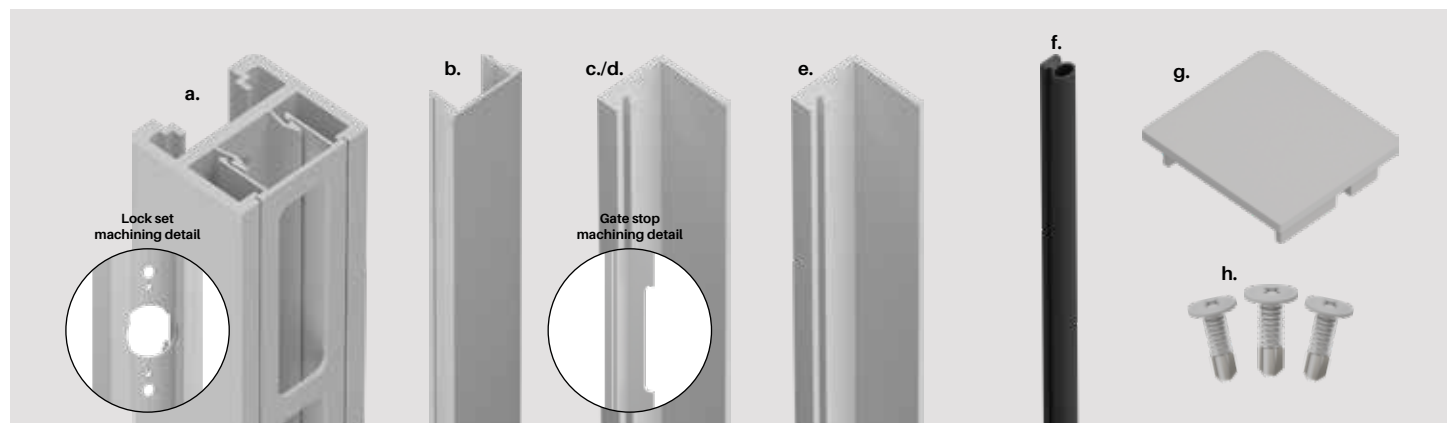

GATE EXTRUSION & ACCESSORIES

20mm gate lockbox kit

SUITABLE FOR LEVER/KNOB LOCK SET

Order Code: **XP-GKIT-LSET20**

- Gate side frame kit is specifically machined to suit horizontal pedestrian gate with lockbox and KNOB/LEVER set
- Patented non-weld assembly system: Use pre-powder coated aluminium lockbox (Code: XP-LBOX-LSET)
- Suits 65x16mm slats with 20mm spacing (Sold separately)
- Lockbox and lever/knob handle sold separately

Finishes

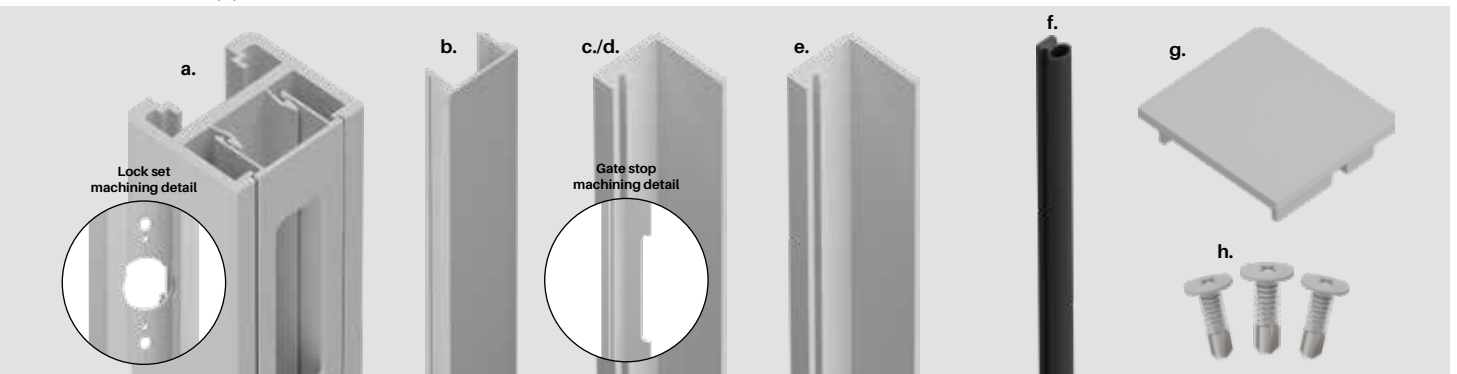

Deadlatch lockbox

ALUMINIUM

Black / Monument / Woodland Grey / Silver / Surfmist / White Basalt / Dune / Mill finish

Order Code: **XP-LBOX-DL**

- Patented non-weld lockbox
- Suits horizontal slat gates with 65x16.5mm slats
- Must use with gate side frame (XP-4200-GSF09/20)
- Screw fix assembly of pre-powder coated lockbox and extrusion
- Suits Lockwood 001 deadlatch (XP-DL001)



Lockwood 001 deadlatch

12Gx65MM HEX
FLANGE HEAD

Order Code: **XP-DL001**

- Lockwood 001 deadlatch to suit metal frames
- Market leading performance & reliability
- Only suits inwards swinging gate
- Cut-resistant stainless steel bolt

Lever/knob lockbox

ALUMINIUM

Black / Monument / Woodland Grey / Silver / Surfmist / White Basalt / Dune / Mill finish

Order Code: **XP-LBOX-LSET**

- Patented non-weld lockbox
- Suits horizontal slat gates with 65x16.5mm slats
- Must use with gate kits (XP-GKIT-LSET09/20)
- Screw fix assembly of pre-powder coated lockbox and extrusion
- Suits knob or lever sets (Stanley or Lockwood models)



Stanley round knob set

STAINLESS STEEL

Order Code: **XP-HDL-KNOB**

- Knob set keyed both sides
- Lock / unlock both sides
- Suits left or right gate opening
- Stainless steel knob and rose
- C4 6 pin restricted compatible (Inside & outside)

Lockwood round knob set

HIGH PURITY ZINC ALLOY

Order Code: **XP-HDL-LW534**

- Lockwood model 534
- Knob set keyed both sides
- Lock / unlock both sides
- Suits left or right gate opening
- Satin Chrome brushed finish
- C4 5 pin on outside
- C4 6 pin restricted compatible on inside



Stanley lever set

STAINLESS STEEL

Order Code: **XP-HDL-LEVER**

- Lever set keyed both sides
- Lock / unlock both sides
- Suits left or right gate opening
- Stainless steel knob and rose
- C4 6 pin restricted compatible (Inside & outside)

GATE ACCESSORIES



Hinge panel brace screws

12Gx40MM – 12 PACK

Black / Monument / Woodland Grey / Silver / Surfmist / White Basalt / Dune / Mill finish

Order Code: XPL-SCHEX-12PK

- Screws fix through post and slat both sides of panel that gate hinges from
- Fix off both sides at top slat and mid slat positions
- Pilot hole required before screw fixing (ensure drill does not penetrate other side of post)
- Must be used to provide rigidity of hinging panel adjacent to gate

Applicable if using XPress PLUS post system next to gate

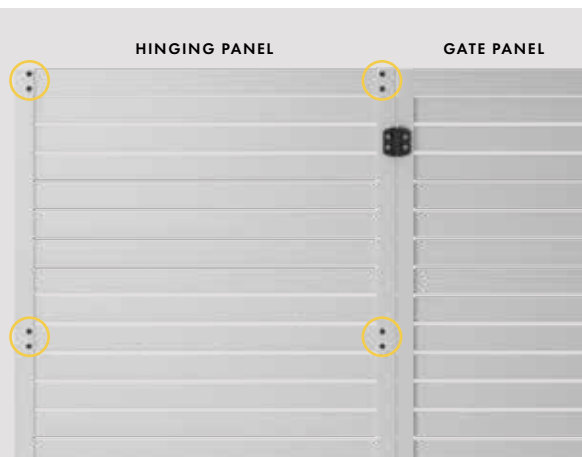
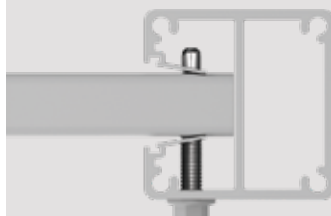

Finishes

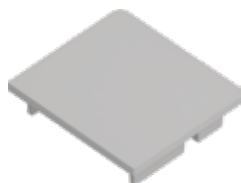

Gate frame cap

NYLON

Black / Monument / Woodland Grey / Silver / Surfmist / White

Order Code: XP-GFC

- UV stabilised nylon – 3mm thick cap
- Available in 5 colours
- Suits gate side frame
- Press-in flat cap

Finishes



Self drilling wafer screws

10Gx16MM – BAG OF 100

Black / Monument / Woodland Grey / Silver / Surfmist / White Basalt / Dune / Mill finish

Order Code: XP-SCREWS

- 10G x 16mm self drilling wafer head zinc plated
- Powder coated heads for neat finish
- Use to screw fix slats to Quickscreen side frame or to affix centre support rail to slats



Countersunk blind rivet

4.0x8.4

Order Code: XP-GATESTOP-RIV-10PK

- Countersunk aluminium rivet – 10 pack
- Use for affixing gate stop to post when using a lockbox with Lockwood 001 deadlatch – due to 3mm gap requirement between gate side frame and post rivets are required (as screw heads may interfere)



PACK OF 10 Gate frame screws

12Gx65MM HEX FLANGE HEAD

Order Code: XP-SCREWSGF-10PK

- Use to secure gate slats to gate side frame through pre-machined holes in gate side frames
- Hex flange head for easy assembly

Electric Striker

Order Code: XP-HDL-ES

- Optional electric striker kit
- SS304 striker – Left or right handing
- Power required to lock/unlock
- 12 volt (DC current)
- LATCHING POST – face mount face plate with built in side keeper
- Requirement to notch latching post to recess electric striker mechanism
- Allow 9mm latching gap
- Compatible with locks: XP-HDL-LW534 XP-HDL-KNOB XP-HDL-LEVER

* Routing template included with kit



Gate stop rubber

4300MM LONG

Order Code: XP-GATESTOP-RUB

- Used as bumper for gate stop (mates with XP-4200-GSTOP)
- Rubber feeds into cavity in gate stop extrusion
- Cut to required length

Nylon packer

USE WITH D&D LOKK LATCH DELUXE

Order Code: XP-PACKER

- UV stabilised nylon
- Must be used when installing a D&D Lokk Latch Deluxe
- Packer aligns Lokk Latch Deluxe with gate side frame
- Affixes to inner face of gate side frame positioned under Lokk Latch striker



GATE ASSEMBLY: SIMPLE OVERVIEW

GATE OPTIONS 1, 3 & 4

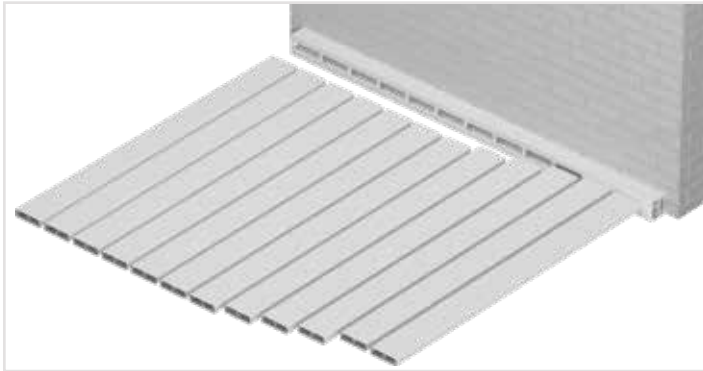

1 On a flat protected surface, lay 1x gate side frame with slotted spacer infill and rest against a padded stop and tap slats and gate blades into place

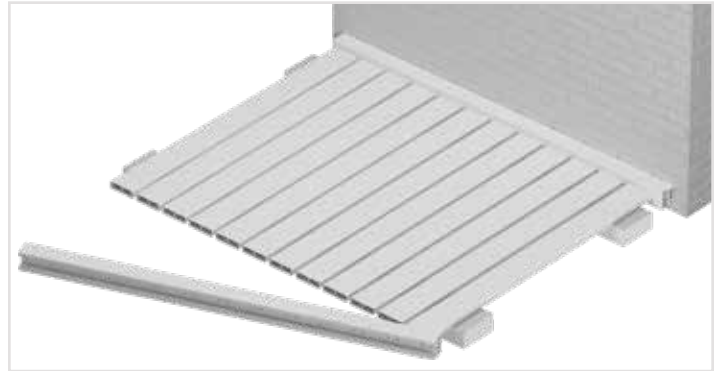

2 Elevate slats and gate side frame on two padded bearers. Engage second gate side frame to slats and tap frame until all slats are fully engaged
TIP: Start at one end and work slats in from one end to the other

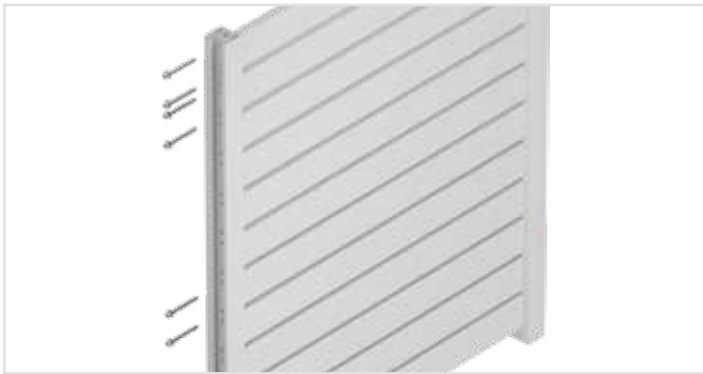

3 Screw off gate blades at required positions. Ensure gate is square by measuring diagonals



4 Slide 2x outer infills down into position to hide screw heads

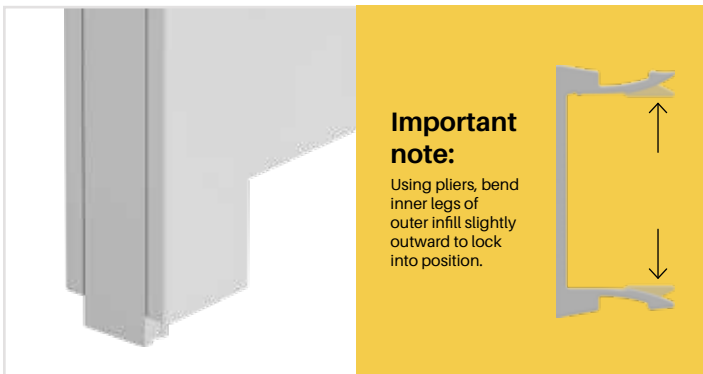

5 Slide 2x outer infills past end of gate side frame (approx. 10mm), then using pliers, bend inner legs of outer infill slightly outwards. Tap outer infill back to level with gate side frame

TIP: This step stops the outer infill from sliding down prior to hardware installation



6 Insert top caps into side frames

To determine the actual slat width for your gate, make a deduction of 36mm to the overall gate width (outer edge to outer edge of gate side frame)

FORMULA FOR SLAT WIDTH:
OVERALL GATE WIDTH – 36MM

You need to allow for hinge and latch gaps
Check hinge and latch hardware specifications for gaps required and take this information into account when determining overall gate width

Contact us for further installation instructions when using lockboxes etc.

GATE ASSEMBLY

GATES WIDER THAN 1500MM

- 1 When the gate is wider than 1500mm, 2x heavy duty top/bottom rails are used in place of the top and bottom gate blades (Additional gate blades are still required as per page 63).

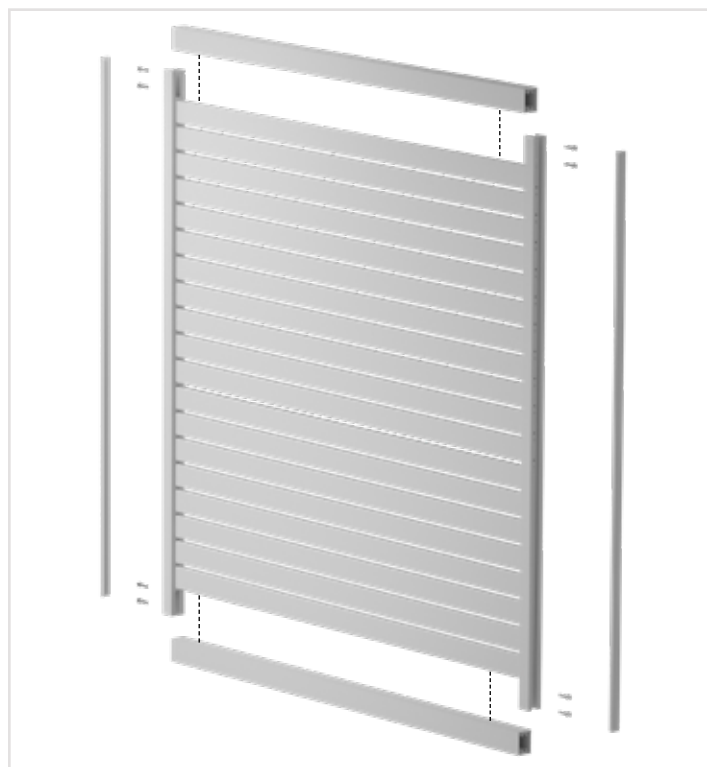

- 2 Once top/bottom rails and all slats are installed, ensure gate is square. The slimline brace must be measured and cut with an aluminium drop saw to run diagonally across the back face of the gate. Secure each slat using XP-SCREWS.

IMPORTANT:

Ensure the slimline brace is installed running from the 'bottom' hinge side corner to the top 'latch' side corner

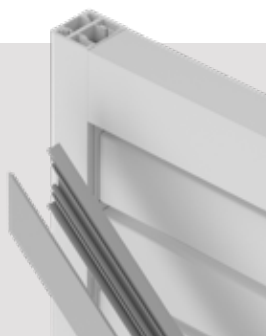

SUGGESTED HINGE FIXING METHOD USING 65MM M8 BOLTS, SPRING WASHERS & NUTS FOR GATES 1500MM AND UNDER

*Hinge fixings not supplied

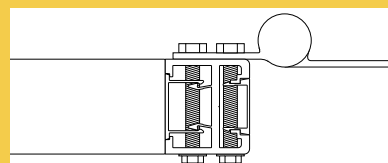

Our range of gate hinges

D&D hinges available as single items or buy in carton lots for large bulk buy discounts on selected lines



D TRU**Close**

TruClose® hinge pair
NO ALIGNMENT LEGS
Order Code: TC-H-AT-B
D&D Code: TCA1S3BT



D TRU**Close**

TruClose® hinge pair
2 ALIGNMENT LEGS
Order Code: TC-H-AT-2L-B
D&D Code: TCA1L23BT



D TRU**Close** HEAVY DUTY

TruClose® hinge pair
Heavy duty
1 ALIGNMENT LEG
Order Code: TC-H-AT-HD-B
D&D Code: TCHD1AL1S3BT



D TRU**Close** HEAVY DUTY

TruClose® hinge pair
Heavy duty
2 ALIGNMENT LEGS
Order Code: TC-H-AT-HD-2L-B
D&D Code: TCHD1AL2S3BT



D KWIK**Fit**

Kwik Fit® hinge pair
FIXED TENSION
Order Code: KF-H-FT
D&D Code: KF3S



D KWIK**Fit**

Kwik Fit® hinge pair
NO TENSION
Order Code: KF-H-NT
D&D Code: KF3P



D KWIK**Fit** ALUMINIUM

Kwik Fit® Aluminium
hinge pair
ADJUSTABLE TENSION
Order Code: KF-AH-AT
D&D Code: KF3ABL



SureClose® Readyfit
hydraulic hinge closer
2 ALIGNMENT LEGS
Order Code: SURECLOSE -HH
D&D Code: 74108313



SureClose®
Readyfit hinge
non self closing
closer
2 ALIGNMENT LEGS
Order Code: SURECLOSE -NSC
D&D Code: 74001313

GATE HINGES

19mm
gap spacing

No
alignment legs

(variable spacing achievable)



TruClose® hinge pair

NO ALIGNMENT LEGS

Order Code: **TC-H-AT-B (Pair)**
BB-TC-H-AT-B (*Bulk buy)

D&D code: TCA153BT

- D&D patented tension adjustment
- Strong, moulded polymer and stainless steel
- Adjust tension from both ends of the hinge
- No visible fixings
- Decorative trim covers available in black finish
- Super strong engineering polymers and stainless steel components
- Won't rust, bind, sag or stain
- Limited lifetime warranty
- Pool fencing compliant - Rated for **gates up to 30kg**

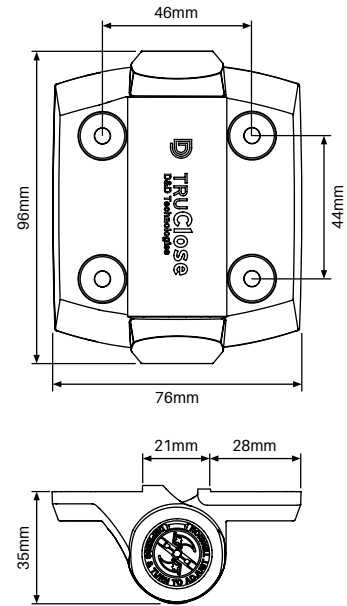

Certi cap – Series 3

Order Code: **TC-CAPS3**

D&D code: TCACAPS3



- Prevents toe hold on hinge
- Durable polymer material

No alignment legs on hinge allows for flexibility when positioning gate onto post

*BULK BUY CARTON QTY: 20 PAIRS

Reinforcing ribs
Moulded ribs provide super strength

Patented adjuster
Easy tension adjustment

Concealed fasteners
Trim covers hide the fasteners to improve the appearance of the gate



Internal stainless steel spring
Won't rust or corrode

Moulded hinge body
Engineering polymers with glass fibre reinforcement are UV stabilised



*Black trim covers only

21mm
gap spacing

2
alignment legs



TruClose® hinge pair

2 ALIGNMENT LEGS

Order Code: **TC-H-AT-2L-B (Pair)**
BB-TC-H-AT-2L-B (*Bulk buy)

D&D code: TCA1L2S3BT

- D&D patented tension adjustment
- Strong, moulded polymer and stainless steel
- Adjust tension from both ends of the hinge
- No visible fixings
- Decorative trim covers available in black finish
- Super strong engineering polymers and stainless steel components
- Won't rust, bind, sag or stain
- Limited lifetime warranty
- Pool fencing compliant - Rated for **gates up to 30kg**

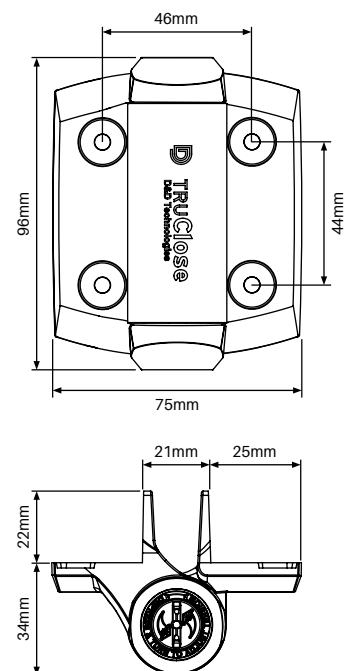

Certi cap – Series 3

Order Code: **TC-CAPS3**

D&D code: TCACAPS3



- Prevents toe hold on hinge
- Durable polymer material

Two alignment legs on hinge allows for quick, easy and accurate positioning of gate onto post

*BULK BUY CARTON QTY: 20 PAIRS

GATE HINGES

19mm
gap spacing

1
alignment leg



D TRUClose® HEAVY DUTY

TruClose® hinge pair Heavy duty

1 ALIGNMENT LEG

Order Code: **TC-H-AT-HD-B (Pair)**
BB-TC-H-AT-HD-B (*Bulk buy)

D&D code: TCHD1AL1S3BT

- D&D patented tension adjustment
- Strong, moulded polymer and stainless steel
- Adjust tension from both ends of the hinge
- No visible fixings
- Decorative trim covers available in black finish
- Super strong engineering polymers and stainless steel components
- Won't rust, bind, sag or stain
- Limited lifetime warranty
- Pool fencing compliant – Rated for **gates up to 70kg**

One alignment leg on hinge allows for quick and sturdy fixing on one side with flexible positioning on the other side

*BULK BUY CARTON QTY: 20 PAIRS

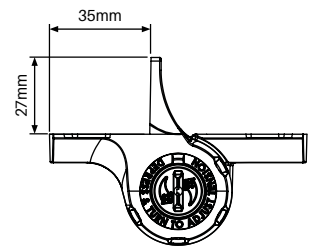
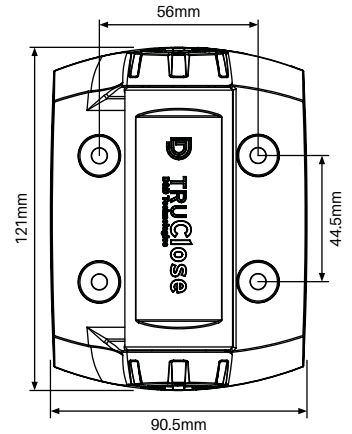

21mm
gap spacing

2
alignment legs



D TRUClose® HEAVY DUTY

TruClose® hinge pair Heavy duty

2 ALIGNMENT LEGS

Order Code: **TC-H-AT-HD-2L-B (Pair)**
BB-TC-H-AT-HD-2L-B (*Bulk buy)

D&D code: TCHD1AL2S3BT

- D&D patented tension adjustment
- Strong, moulded polymer and stainless steel
- Adjust tension from both ends of the hinge
- No visible fixings
- Decorative trim covers available in black finish
- Super strong engineering polymers and stainless steel components
- Stylish and contemporary design
- Won't rust, bind, sag or stain!
- Limited lifetime warranty
- Pool fencing compliant – Rated for **gates up to 70kg**

Two alignment legs on hinge allows for quick, easy and accurate positioning of gate onto post

*BULK BUY CARTON QTY: 20 PAIRS

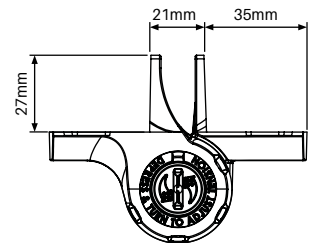
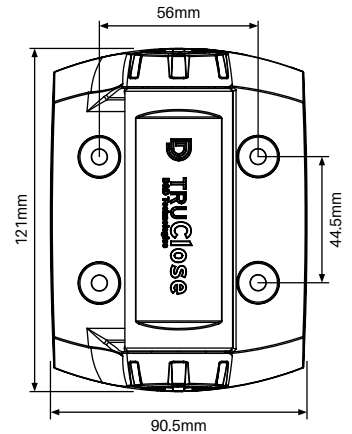

GATE HINGES

20mm
gap spacing

Fixed tension



Kwik Fit® hinge pair

FIXED TENSION

Order Code: KF-H-FT (Pair)

BB-KF-H-FT (*Bulk buy)

D&D code: KF35

- Self closing fixed tension hinges
- Rated to 20kg self close (D&D)
- Alignment legs for ease of fitting
- Strong polymer and stainless steel
- Torsion spring construction
- Pool fencing compliant

*BULK BUY CARTON QTY: 50 PAIRS

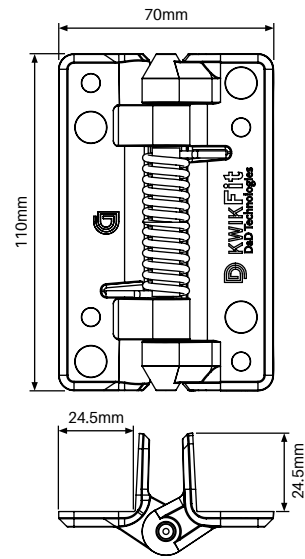

20mm
gap spacing

No tension



Kwik Fit® hinge pair

NO TENSION

Order Code: KF-H-NT (Pair)

BB-KF-H-NT (*Bulk buy)

D&D code: KF3P

- Standard pivot hinges (No self close)
- Rated to 25kg gates (D&D)
- Alignment legs for ease of fitting
- Strong polymer construction
- Ideal for boundary gates

*BULK BUY CARTON QTY: 50 PAIRS

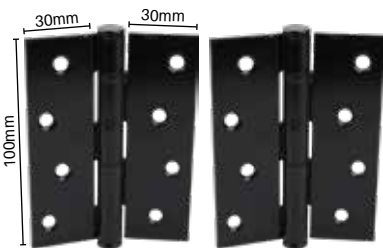
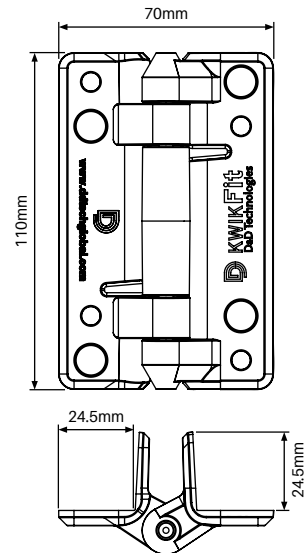

Butt hinge pair

100MM H x 75MM W

Order Code: SS-BH10075-B

- Cost effective where self closing hinge is not required
- Zinc plated steel
- Powder coated black
- Multiple fixing points - Ø6mm holes
- Not self closing



Butt Hinge Pair

PAIR OF 2

(includes 17 x matching colour tek screws)

17 x tek screws

Order Code: CB-HINGE-B-2PK

- Made from galvanised steel & powder coated
- 6.5mm diameter fixing holes
- 2.5mm thick hinge leaf

Finishes

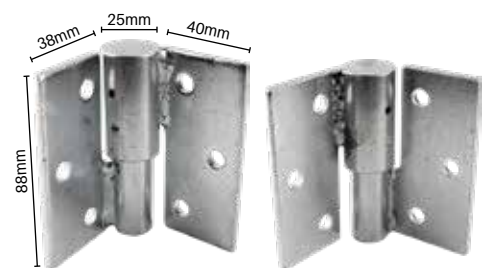

Zeus hinges

Order Code: ZF-BBH-L/R (Left/Right)

- Bolt on ball bearing hinge pair
- Left and right hinges available
- Galvanised steel construction
- Sturdy, long lasting hinges
- Suits heavy/wide hinge gates
- Not self closing

GATE HINGES

19mm
gap spacing

Adjustable
tension

D® KWIKFit® ALUMINIUM

Kwik Fit® Aluminium hinge pair

ADJUSTABLE TENSION

Order Code: **KF-AH-AT (Pair)**
BB-KF-AH-AT (*Bulk buy)

D&D code: **KF3ABL**

- Powder coated black aluminium hinges
- D&D patented tension adjustment - 6 tension settings, adjustable from both ends
- Self closing hinge - closes gates up to 20kg
- Internal stainless steel spring
- Wall and post mounting hinges
- Tested to over 300,000 cycles
- Pool fencing compliant

*BULK BUY CARTON QTY: 16 PAIRS

POST TO GATE
INSTALLATION



OR

WALL TO GATE
INSTALLATION



Wall to gate installation

Fit to posts or walls
Adjustable fixing plate

POST TO GATE INSTALLATION

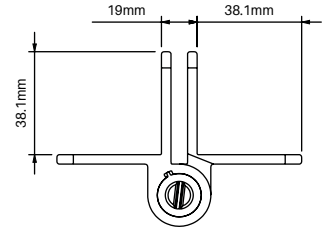

WALL TO GATE INSTALLATION

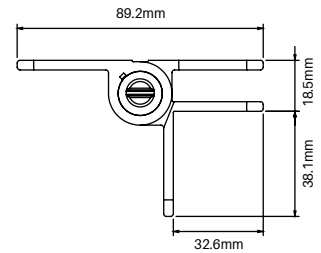

12-35mm
gap spacing



FIXING SCREWS SUPPLIED
MIN POST SIZE: 50MM

Sureclose – Readyfit hinge

HYDRAULIC HINGE CLOSER 2 ALIGNMENT LEGS

Order Code: **SURECLOSE-HH**
D&D Order Code: **74108313**

- Ideal for commercial/industrial applications
- Easy install - screw on externally mounted
- Self close gates up to 120kg
- Heavy duty, 50 micron black anodised aluminium
- Sold as **SINGLE** hinge
- **SELF CLOSING FROM 83 degrees**
- **HOLES OPEN AT 90 deg** to 180 deg
- **MAX GATE OPENING 178 deg**

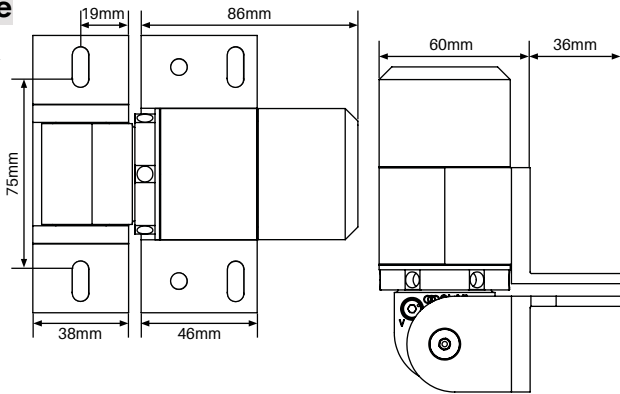

TRADE TIP: Commonly a hydraulic closer hinge is installed on the bottom of the gate (SURECLOSE-HH) with the non self closing hinge at top of gate (SURECLOSE-NSC). For very heavy gates, 2 x closer hinges may be considered.

12-35mm
gap spacing



FIXING SCREWS SUPPLIED
MIN POST SIZE: 50MM

Sureclose – Readyfit hinge

NON SELF CLOSING CLOSER 2 ALIGNMENT LEGS

Order Code: **SURECLOSE-NSC**
D&D Order Code: **74001313**

- Ideal for commercial/industrial applications
- Easy install - screw on externally mounted
- **NON SELF CLOSING** hinge
- Heavy duty, 50 micron black anodised aluminium
- Sold as **SINGLE** hinge
- **LOAD BEARING** non self closing hinge
- **MAX GATE OPENING 178 deg**

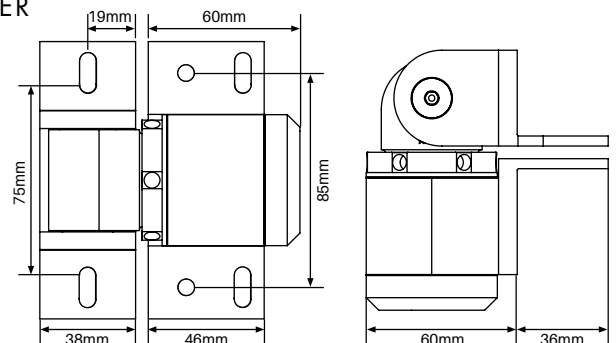

Our range of gate latches

D&D latches available as single items or buy in carton lots for large bulk buy discounts



D LOKK**Latch** DELUXE

Lokk Latch[®] deluxe

KEYED ALIKE

Order Code: LL-DL-KA

D&D Code: LLDABS2LA



D LOKK**Latch** DELUXE

Lokk Latch[®] deluxe

KEYED TO DIFFER

Order Code: LL-DL

D&D Code: LLDABS2-L



D LOKK**Latch**

Lokk Latch[®]

KEYED TO DIFFER

Order Code: LLAA

D&D Code: LLAA



D LOKK**Latch**

Lokk Latch[®] external access kit

KEYED TO DIFFER

Order Code: LLB

D&D Code: LLB



D MAGNA**Latch**

Top pull lockable latch

Order Code: ML-TL

D&D Code: ML3TPLA



D D&D Technologies
Hi-Performance Hardware

Face mount lockable latch

Order Code: MR-FMLS

D&D Code: MLSPS2L



D D&D Technologies
Hi-Performance Hardware

T latch

Order Code: T-L

D&D Code: TL01



D latch

Order Code: SS-DL-B

GATE LATCHES

15-40mm
gap spacing

KEYED ALIKE



LOKKLatch® DELUXE

Lokk Latch® deluxe

Order Code: LL-DL-KA (Single)
BB-LL-DL-KA (*Bulk buy)

D&D code: LLDABS2LA

- Lockable from both sides of gate
- Locks are keyed alike
- Rekeyable, 6-pin security lock
- Fits up to 150mm deep posts
- Black polymer

*BULK BUY CARTON QTY: 20PCS

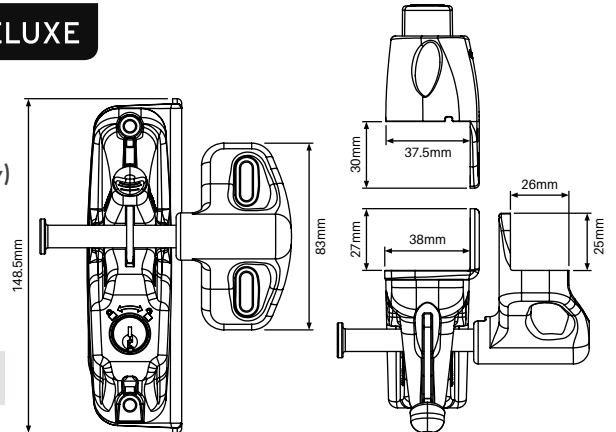

15-40mm
gap spacing

KEYED TO DIFFER



LOKKLatch® DELUXE

Lokk Latch® deluxe

Order Code: LL-DL (Single)
BB-LL-DL (*Bulk buy)

D&D code: LLDABS2-L

- Lockable from both sides of gate
- Locks are keyed to differ
- Rekeyable, 6-pin security lock
- Fits up to 150mm deep posts
- Black polymer

*BULK BUY CARTON QTY: 20PCS

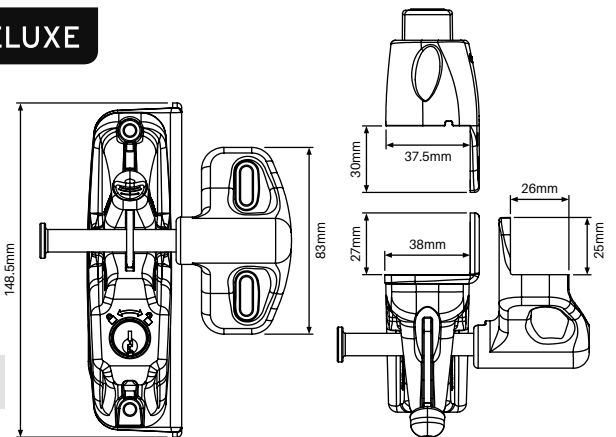

15-40mm
gap spacing

KEYED TO DIFFER



LOKKLatch®

Lokk Latch®

Order Code: LLAA (Single)
BB-LLAA (*Bulk buy)

D&D code: LLAA

- Ideal latch for home and garden gates
- Key lockable - no need for padlocks or chains
- Fit with or without External Access Kit (LLB)
- Quick and easy to install on all gate materials
- Strong polymer design will not rust or stain
- Minimum post size for fitting - 25mm

*BULK BUY CARTON QTY: 20PCS

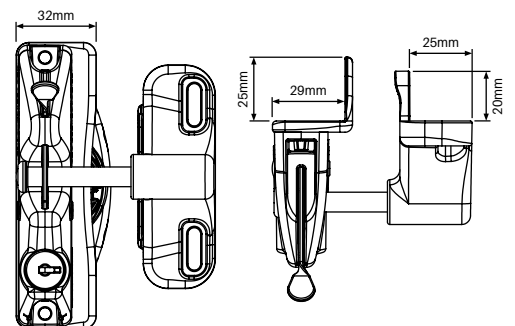

LOKKLatch®

Lokk Latch® external access kit

Order Code: LLB (Single)
BB-LLB (*Bulk buy)

D&D code: LLB

- Optional extra external access kit
- Matches with LLAA
- Allows opening of LLAA from other side of gate
- NOTE: locking external access button does not lock the main latch

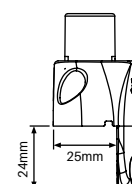

*BULK BUY CARTON QTY: 10PCS

GATE LATCHES

13-38mm
gap spacing



MAGNALatch

Top pull lockable latch

Order Code: **ML-TL (Single)**
BB-ML-TL (*Bulk buy)

D&D code: ML3TPLA

- Magnetically triggered lockable latch
- Improved stylish "Series 3" design
- Adjusts horizontally and vertically
- Includes adjustable striker plate
- D&D Limited lifetime warranty
- Quick and easy installation
- Tested to over 400,000 cycles

*BULK BUY CARTON QTY: 20PCS

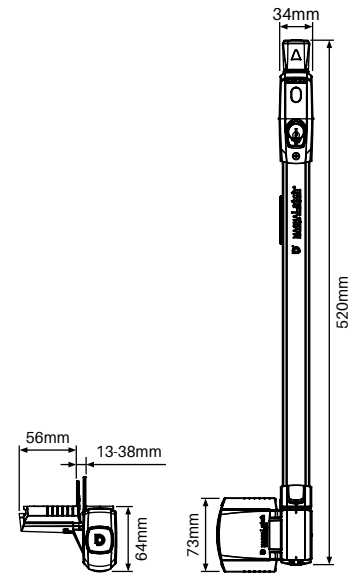

8-10mm
gap spacing



D&D Technologies Hi-Performance Hardware

Face mount lockable latch

Order Code: **MR-FMLS (Single)**
BB-MR-FMLS (*Bulk buy)

D&D code: MLSP52L

- Suits retrofitting to previously fitted standard side pull latch installations
- Key lockable
- Adjusts horizontally and vertically
- Limited lifetime warranty
- Black polymer

*BULK BUY CARTON QTY: 10PCS

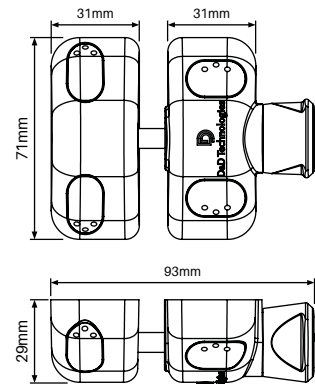

10-45mm
gap spacing



*Padlock not included

D&D Technologies Hi-Performance Hardware

T latch

Order Code: **T-L (Single)**
BB-T-L (*Bulk buy)

D&D code: TL01

- Padlockable toggle latch
- Lockable from one side only

*BULK BUY CARTON QTY: 20PCS

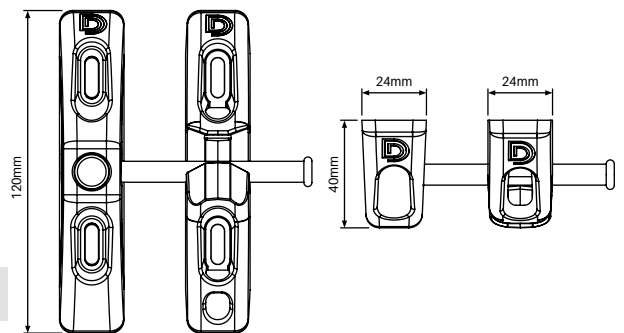

10-35mm
gap spacing



D latch

Order Code: **SS-DL-B**

- Easy to install D latch and striker
- Includes 4x tek screws
- Cost effective latching solution

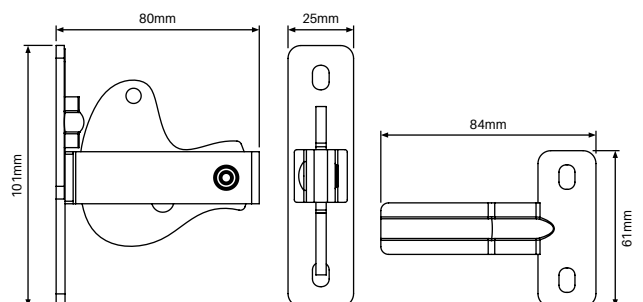

GATE LATCH & HINGE KITS



Magna Latch® with Kwik Fit® hinge pair

FIXED TENSION

Order Code: **ML-TL-KF-H-FT (Single)**
BB-ML-TL-KF-H-FT (*Bulk buy)

D&D code: ML3KFSK

- Kit includes D&D top pull Magna latch and 2x KWIK fit hinges (KF3S model)
- Self closing fixed tension hinges (20mm gap for hinges)
- Pool fencing compliant - Rated for gates up to 20kg
- Magnetically triggered lockable latch

*BULK BUY CARTON QTY: 20PCS

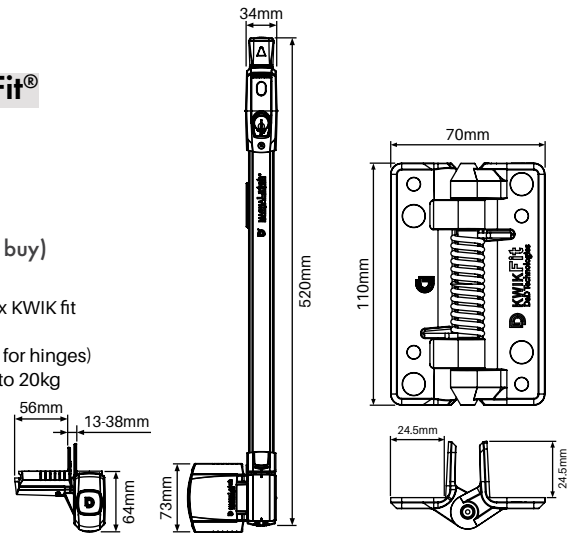

Magna Latch® with Tru Close® hinge pair

ADJUSTABLE TENSION

Order Code: **ML-TL-TC-H-AT (Single)**
BB-ML-TL-TC-H-AT (Bulk buy)

D&D code: MTSTDKS3LA

- Kit includes D&D top pull Magna latch and 2x TRU close hinges
- Patented tension adjustable hinges (TC-H-A-B version hinges - no alignment legs on hinges provides for flexible installation)
- Pool fencing compliant - Rated to 25kg self close
- Magnetically triggered lockable latch

*BULK BUY CARTON QTY: 20PCS

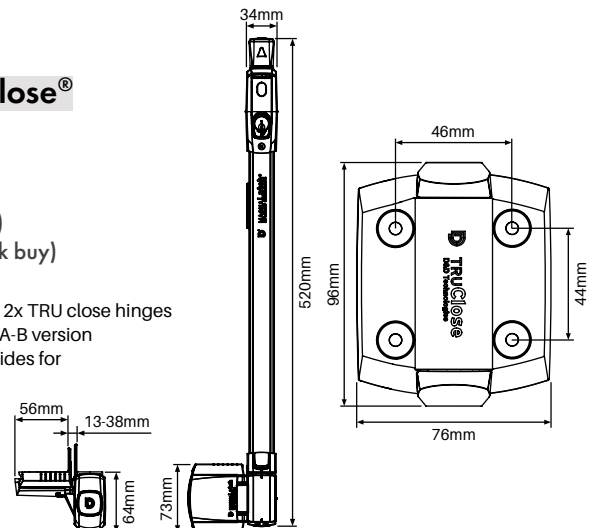

Self drilling tek screws

12Gx20mm – BAG OF 100

Black, Woodland Grey, Monument, Primrose, Paperbark, Silver, Surfmist & White

Order Code: SS-TS-100

- Self drilling tek screw featuring integrated thread and drill/cutting tip
- 12G x 20mm tek screw with hex head
- Packed in convenient bags of 100 screws



Soudafix CA1400 Chemical anchor

280mL

Order Code: **SODU-CA1400**

- High performance, two-component chemical anchoring resin for the pressure-free securing of anchoring rods, studs, threaded collars etc
- Fast cure
- Vinyl ester styrene free
- Can be used in damp concrete
- Apply with standard caulking gun

FENCING ACCESSORIES

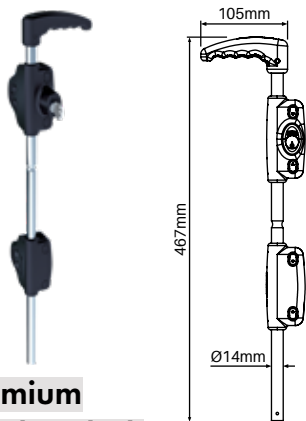

D&D Premium lockable drop bolt

Black finish

Order Code: **LB-PL** (Single)
BB-LB-PL (*Bulk buy)

D&D code: LL118BX-LA

- 316 marine-grade stainless steel drop-rod
- Tough polymer-housing mounting system
- 6-pin lock (rekeyable to match doors & gate locks)

*BULK
BUY QTY:
10PCS



D&D Padlockable drop bolt

Black finish

Order Code: **QB124** (Single)
BB-QB124 (*Bulk buy)

D&D code: QB124

- Powder coated black, stainless steel drop-bolt
- Padlockable (*Padlock not included)
- Tough, moulded polymer mounting system

*BULK
BUY QTY:
10PCS



300mm drop bolt

Black or zinc plated finish

Order Code: **SS-0300DB-B/ZP**

- Ideal for driveway gates
- Cost effective drop bolt
- Easy to install

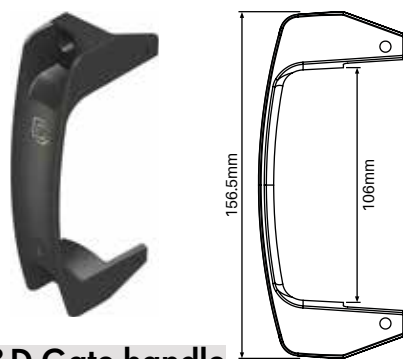

D&D Gate handle

Black polymer finish

Order Code: **LL-GH** (Single)
BB-LL-GH (*Bulk buy)

D&D code: LL3GH

- Side-fixing legs for quick alignment
- Fits left-hand or right-hand opening gates
- Won't rust or stain: strong polymer construction

*BULK
BUY QTY:
20PCS

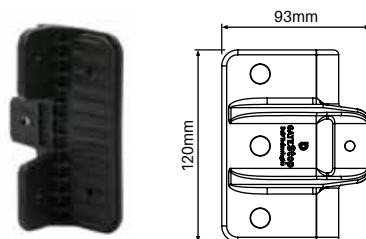

D&D Gate stop

Black polymer finish

Order Code: **SS-GS** (Single)
BB-SS-GS (*Bulk buy)

D&D code: TCG53

- Ideal gate alignment device
- Prevents damage to latches & hinges
- Greatly reduces gate-slam noise
- Tough, durable polymer + rubber bumper

*BULK
BUY QTY:
10PCS



Now available in white!

Post plugs – 4 pack

Black or White finish

Order Code: **SS-POSTPLUG-4PK**
SS-POSTPLUG-4PK-W

- Ø32mm outer top suits 25mm hole
- Suits post wall thickness 1.5mm – 3.2mm
- Cap holes in posts when fixing posts to structures



Bostik V60

Clear glazing silicone

300g

Order Code: **FB-V60**

- Architectural grade high performance glazing silicone
- Neutral cure sealant specially formulated – skins quickly and provides long term performance
- Seals water tight – UV and weather resistant
- Compatible substrates glass, steel, timber, concrete, ceramic, fiberglass, aluminium (powder coated surfaces are limited)



Soudal heavy duty cartridge gun

Order Code: **SODU-GUN**

- Heavy duty, steel trade quality cartridge gun
- Geared ratio 18:1 for smooth operation and easy application
- Dripless system feature automatically releases pressure to reduce mess/waste
- Suits 300ml silicone cartridges and 280ml chemical anchor



Soudal Epofix

82A

300g

Order Code:
SODU-EPOFIX

- 24ml bottle
- Translucent fast curing 2 part epoxy
- Very strong bonding of many types of materials including metal, wood, glass and plastics

Our range of white



AUSTRALIAN INDUSTRY FIRST



GENUINE D&D WHITE HARDWARE



D® **TRUClose**®

TruClose® hinge pair

2 ALIGNMENT LEGS

Order Code: TC-H-AT-2L-W



D® **TRUClose**® **HEAVY DUTY**

TruClose® hinge pair

Heavy duty

2 ALIGNMENT LEGS

Order Code: TC-H-AT-HD-2L-W



D® **KWIKFit**® **ALUMINIUM**

Kwik Fit® Aluminium

hinge pair

ADJUSTABLE TENSION

Order Code: KF-AH-AT-W



D® **LOKKLatch**®

Lokk Latch®

KEYED TO DIFFER

Order Code: LLAA-W



D® **LOKKLatch**® **DELUXE**

Lokk Latch® deluxe

KEYED TO DIFFER

Order Code: LL-DL-W



D® **TRUClose**® **HEAVY DUTY**

D® **LOKKLatch**® **DELUXE**

**Lokk latch deluxe &
TruClose heavy duty
hinge pair**

HINGE & LATCH KIT

Order Code: LLDL-TCHD-W

21 mm
gap spacing

2
alignment legs

TRUClose®

TruClose® hinge pair

2 ALIGNMENT LEGS

Order Code: TC-H-AT-2L-W (Pair)
BB-TC-H-AT-2L-W (Bulk Buy)

- D&D patented tension adjustment
- Strong, moulded polymer and stainless steel
- Adjust tension from both ends of the hinge
- No visible fixings
- Super strong engineering polymers and stainless steel components
- Won't rust, bind, sag or stain
- Limited lifetime warranty
- White polymer
- Pool fencing compliant - Rated for gates up to 30kg



Two alignment legs on hinge allows for quick, easy and accurate positioning of gate onto post

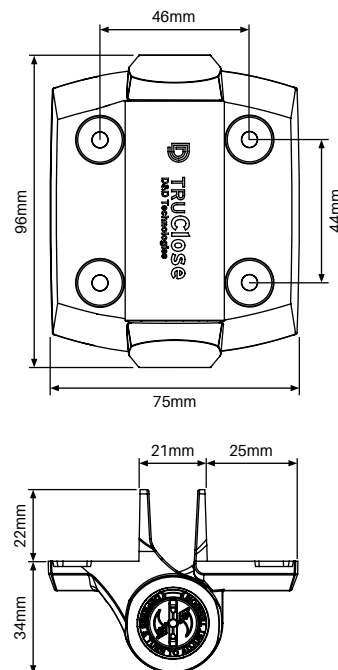

21 mm
gap spacing

2
alignment legs

TRUClose® HEAVY DUTY

TruClose® hinge pair

Heavy duty

2 ALIGNMENT LEGS

Order Code: TC-H-AT-HD-2L-W (Pair)
BB-TC-H-AT-HD-2L-W (Bulk Buy)

- D&D patented tension adjustment
- Strong, moulded polymer and stainless steel
- Adjust tension from both ends of the hinge
- No visible fixings
- Super strong engineering polymers and stainless steel components
- Stylish and contemporary design
- Won't rust, bind, sag or stain!
- Limited lifetime warranty
- White polymer
- Pool fencing compliant - Rated for gates up to 70kg



Two alignment legs on hinge allows for quick, easy and accurate positioning of gate onto post

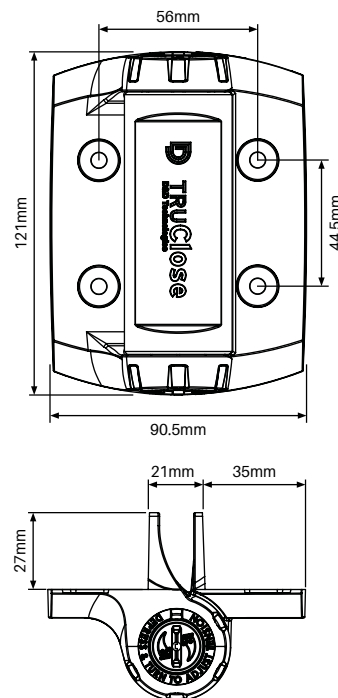

19 mm
gap spacing

Adjustable
tension

KWIKFit® ALUMINIUM

Kwik Fit® Aluminium hinge pair

ADJUSTABLE TENSION

Order Code: KF-AH-AT-W (Pair)
BB-KF-AH-AT-W (Bulk Buy)

- Powder coated white aluminium hinges
- D&D patented tension adjustment - 6 tension settings, adjustable from both ends
- Self closing hinge - closes gates up to 20kg
- Internal stainless steel spring
- Wall or post mounting hinges
- Tested to over 300,000 cycles
- Pool fencing compliant

POST TO GATE
INSTALLATION



Fit to posts or walls

Adjustable fixing plate

POST TO GATE INSTALLATION

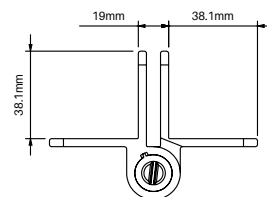

WALL TO GATE INSTALLATION

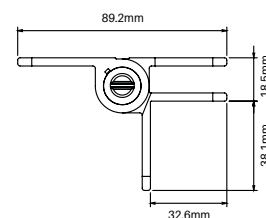

WHITE GATE LATCHES

15-40mm
gap spacing

KEYED TO DIFFER



D LOKK Latch®

Lokk Latch®

Order Code: **LLAA-W**
BB-LLAA-W (Bulk Buy)

- Ideal latch for home and garden gates
- Key lockable - no need for padlocks or chains
- Quick and easy to install on all gate materials
- Strong polymer design will not rust or stain
- Minimum post size for fitting - 25mm
- White polymer

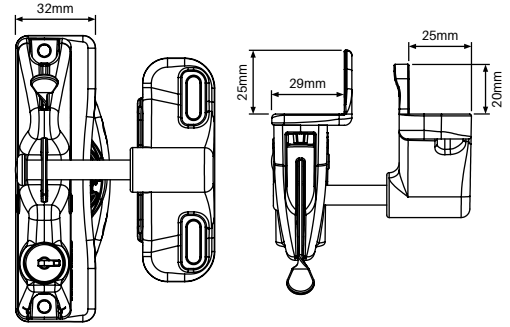

15-40mm
gap spacing

KEYED TO DIFFER



D LOKK Latch® DELUXE

Lokk Latch® deluxe

Order Code: **LL-DL-W**
BB-LL-DL-W (Bulk Buy)

- Lockable from both sides of gate
- Locks are keyed to differ
- Rekeyable, 6-pin security lock
- Fits up to 150mm deep posts
- White polymer

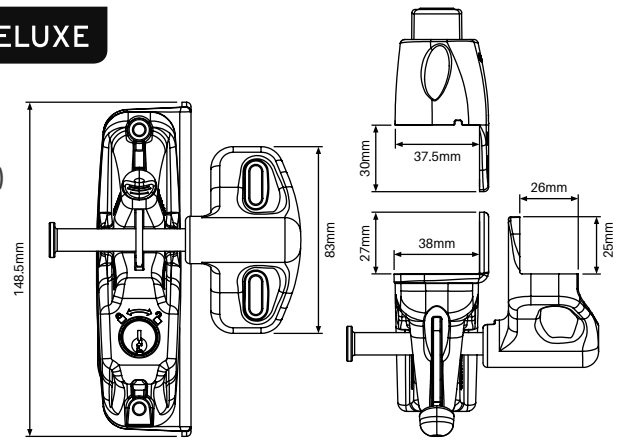

GATE LATCH & HINGE KIT

21mm hinge gap spacing
2 alignment legs



D TRUClose® HEAVY DUTY

D LOKK Latch® DELUXE

Lokk latch deluxe & TruClose hinge pair Heavy duty

HINGE & LATCH KIT

Order Code: **LLDL-TCHD-W**
BB-LLDL-TCHD-W (Bulk Buy)

- Kit includes D&D Lokk Latch Deluxe and 2x TRU close hinges heavy duty
- Pool fencing compliant - Rated to 70kg self close
- Latch is lockable from both sides of gate
- Ideal for aluminium screening & Hamptons gates
- White polymer

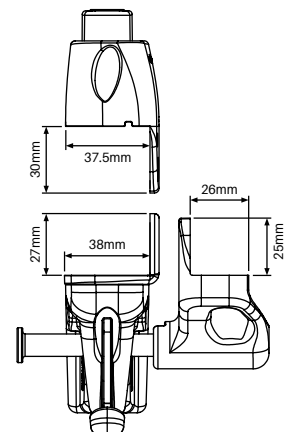
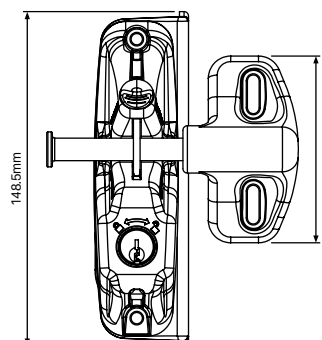
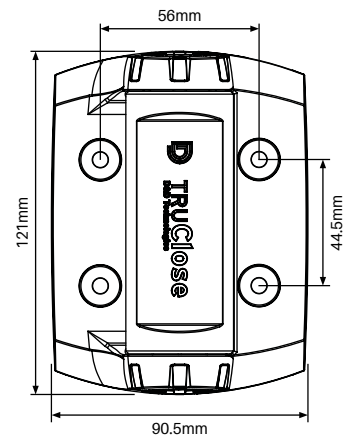

15-40mm latch gap spacing
+ keyed to differ

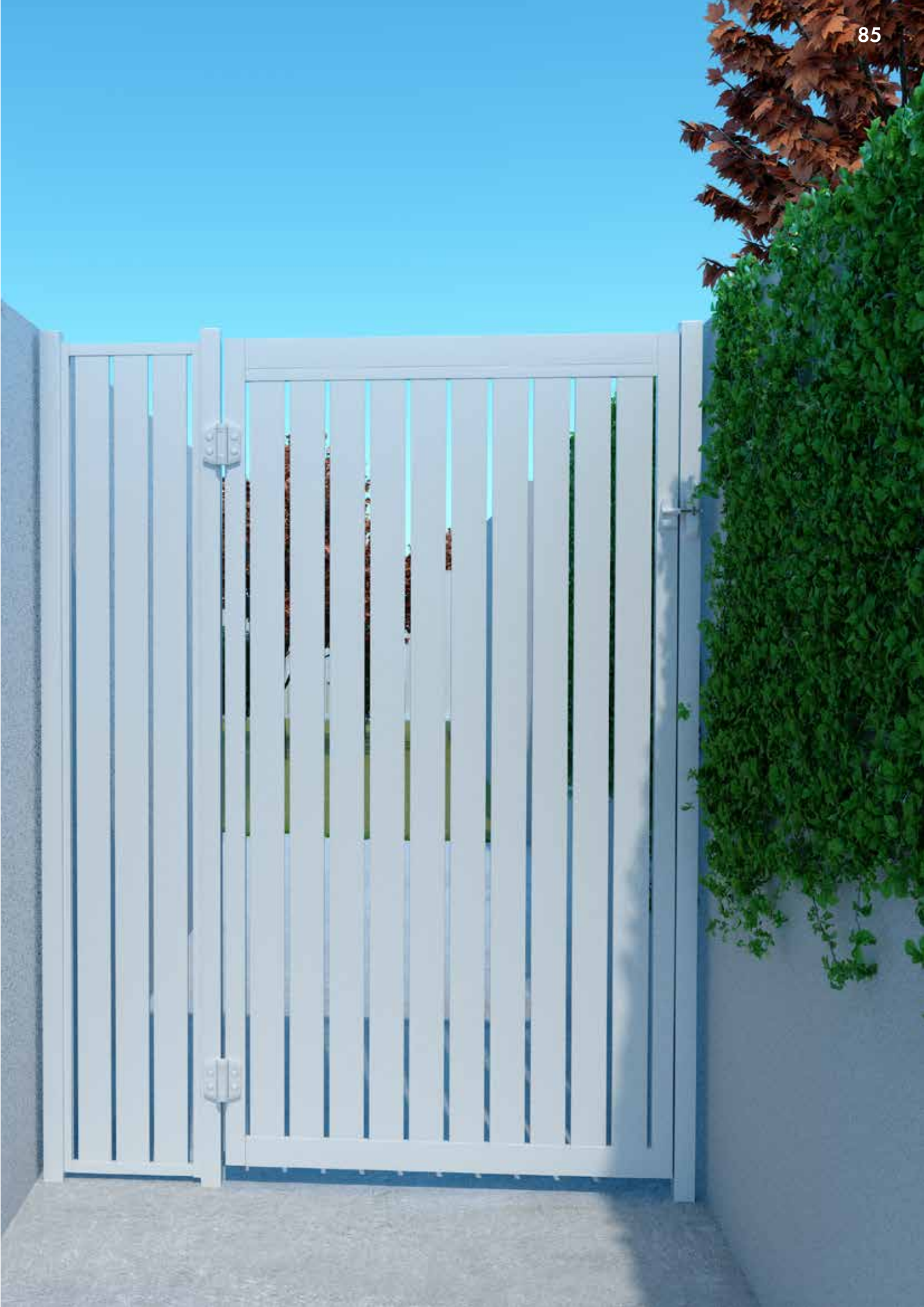

1
Long length supply

Buy long length extrusions then cut to size and assemble on-site or at your premises

2
Cut to size service

Simply provide gate size required – we will cut to size and flat pack for easy assembly

industry first, trade quality Sliding gates

AVAILABLE IN 2 CONVENIENT SUPPLY OPTIONS



Cut to size order forms for sliding gates

For cut to size orders, simply enter required height and width – our handy order form will then generate instant pricing for your order

We will then take your order, cut to size and flat pack for delivery Australia wide.

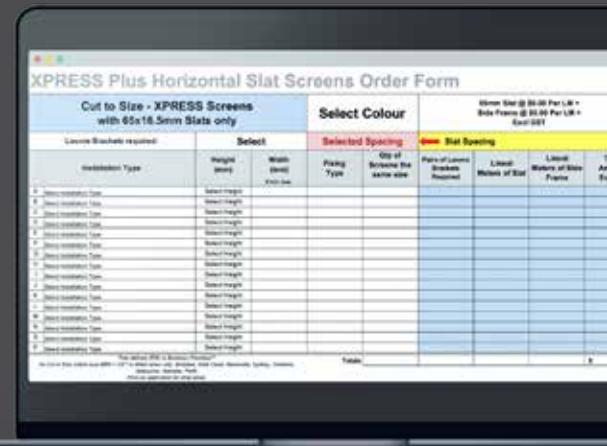

Sliding gate options

SELECT FROM A RANGE OF SLIDING GATE OPTIONS

We can cut to size, flat pack and send Australia wide or you can purchase long length extrusions and cut to size yourself

Assemble pre-powder coated sliding gates quickly and easily with no welding or riveting required

Save time and money without requirement of fully fabricating and welding

Contact us for detailed assembly instructions

1

Horizontal slat sliding gate

65mm x 16.5mm slats with 9mm or 20mm slat spacing

Patented 'no weld' gate side frames for fast assembly

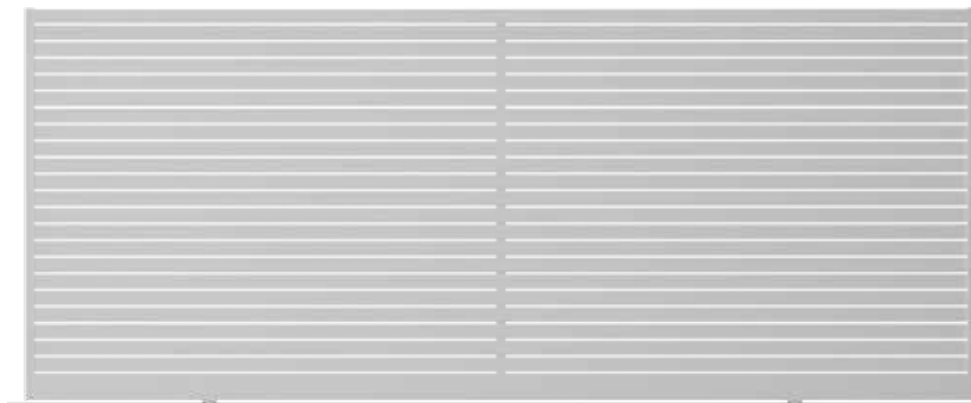

2

Horizontal slat sliding gate

65mm x 16.5mm or 90mm x 16.5mm slats

Variable slat spacing

Each slat required to be screw fixed

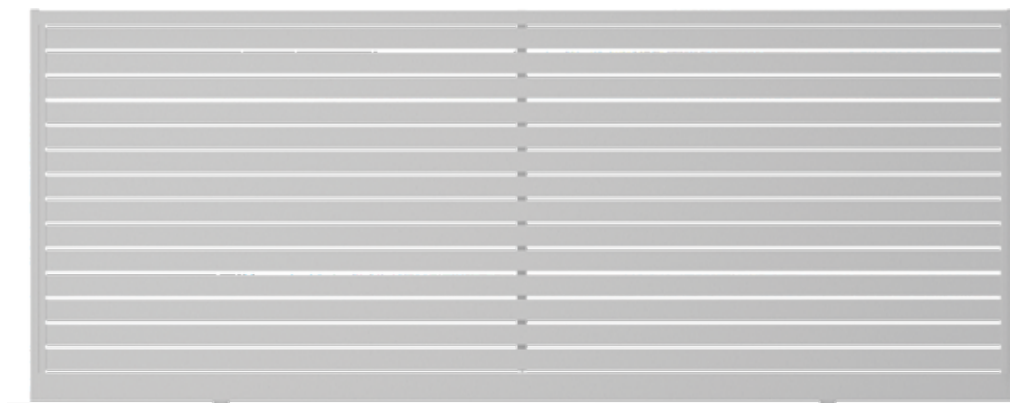

3

Vertical slat sliding gate

65mm x 16.5mm or 90mm x 16.5mm slats

Variable slat spacing

Each slat required to be screw fixed

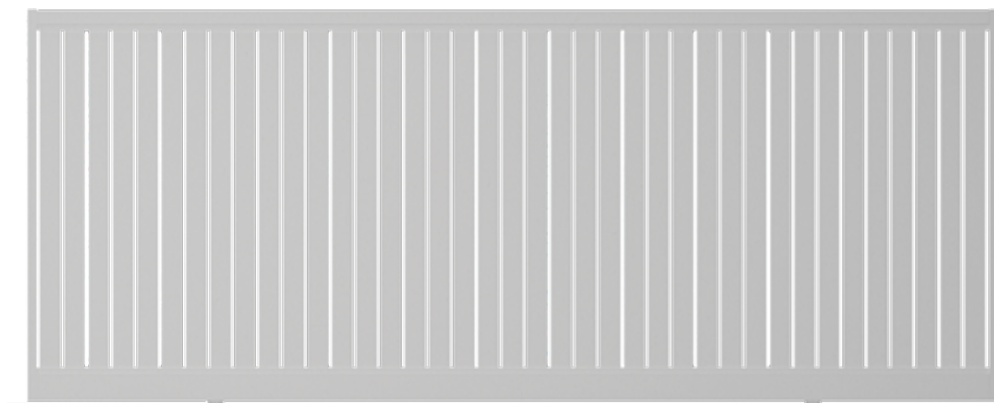

SLIDING GATE OPTIONS

Option 1

Horizontal slat sliding gate with 65mm x 16.5mm slats
9mm or 20mm slat spacing
Patented 'no weld' side frames

SEE PAGES 91-97 FOR FULL
SPECIFICATIONS ON ALL
PRODUCTS LISTED BELOW

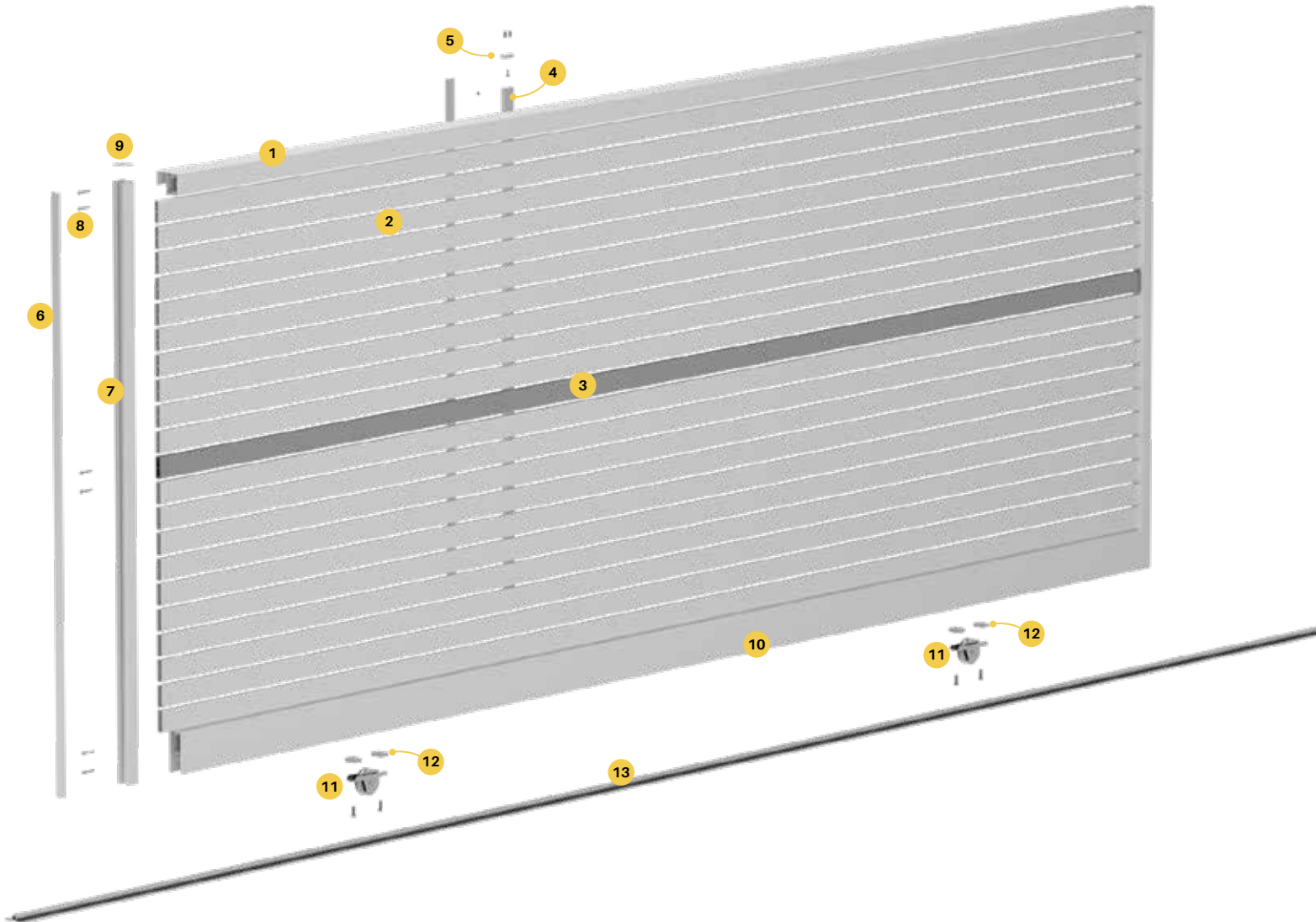

- | | | |
|--|--|--|
| <p>1 Top rail
Rail includes innovative side channel for slide guide or roller guide integration
Screw fix to side frames
XPSG-6100-TR</p> | <p>5 Top/bottom plate for centre support rail
Connects centre support rail to top and bottom rail for extra rigidity
XP-BTP</p> | <p>9 Gate frame cap
Presses into top of gate frames
XP-GFC</p> |
| <p>2 65x16.5mm slat
Standard slats held in place with patented friction fitting gate side frame
XP-6100-S65</p> | <p>6 Gate insert
Snaps into gate side frame to hide screw fixings
XP-4200-GI</p> | <p>10 Bottom Rail
Bottom rail features underside cavity for easy wheel recess fitting
Screw fixes to side frames
XPSG-6100-BR</p> |
| <p>3 65mm x 16.5mm gate slat with 2x screw flutes
Screw fluted slat at middle of gate provides extra rigidity
XP-6100-GB65</p> | <p>7 Gate side frames
Machined drill holes & slots
9mm or 20mm spacing
Suits 65x16.5mm slat
XP-4200-GSF09 or XP-4200-GSF20</p> | <p>11 Sliding gate wheel
80mm diameter wheel with 20mm diameter groove
XPSG-WHEEL</p> |
| <p>4 Centre support rail
Affixes to backside of gate slats
Screw fix each slat for extra support
Snap on cover hides all screws
XP-5800-CSR</p> | <p>8 Gate frame screws
12 gauge x 65mm long with flange hex head
Heavy duty screw fixing of side frame to top/bottom rail and gate blade
XP-SCREWSGF-10PK</p> | <p>12 Wheel clamping set
Clamps gate wheel to bottom rail
XPSG-WHEEL-CS</p> |
| | | <p>13 Gate track
Bolt down track with 20mm diameter running surface – Steel or aluminium
Consider anchor pins to secure track
XPSG-3000/6000-TRACK-ST or XPSG-6000-TRACK-AL</p> |

SLIDING GATE OPTIONS

Option 2

Horizontal slat gate with 65mm or 90mm x 16.5mm slats
Variable slat spacing including nil spacing

SEE PAGES 91-97 FOR FULL
SPECIFICATIONS ON ALL
PRODUCTS LISTED BELOW

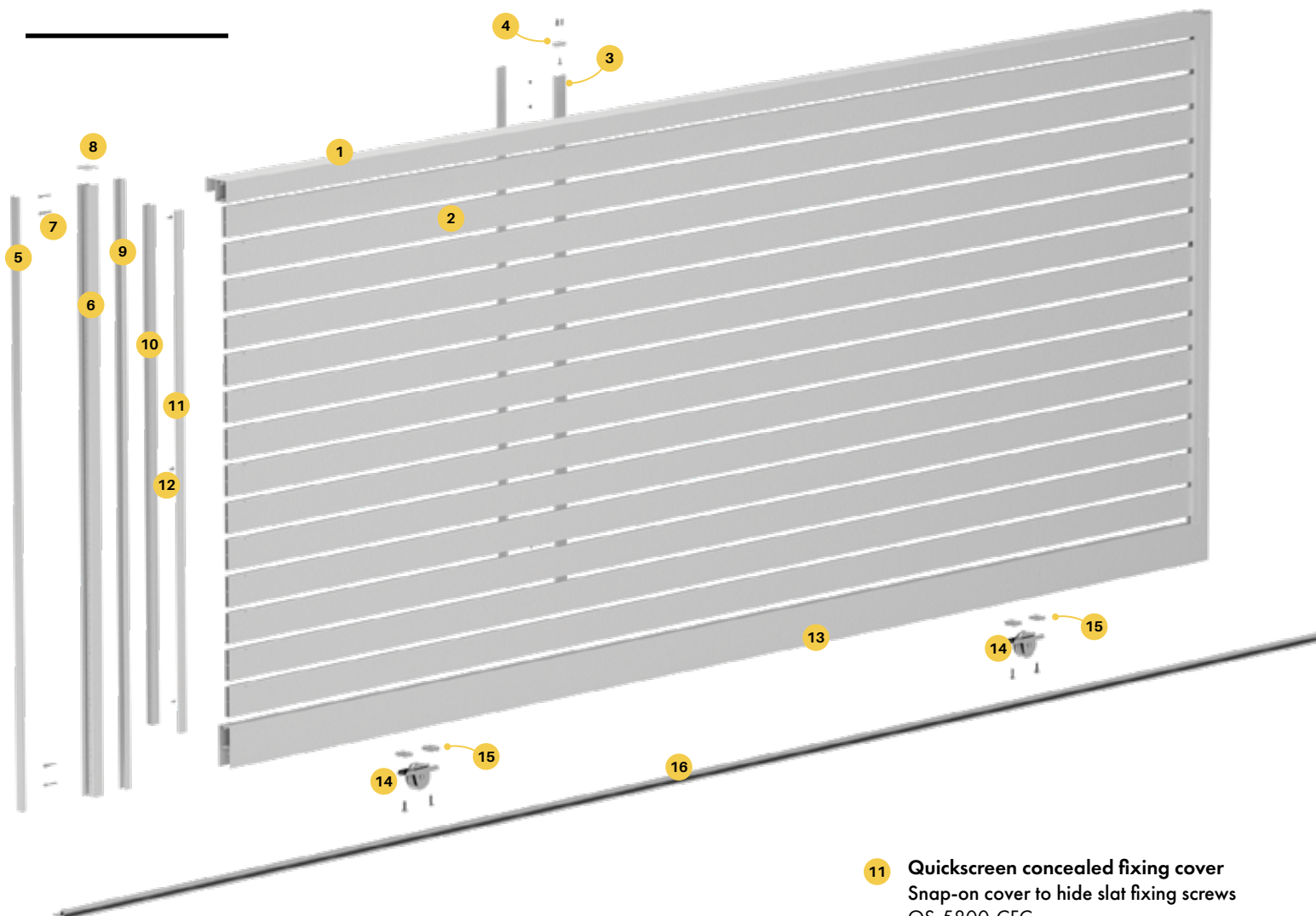

- 1 Top rail**
Rail includes innovative side channel for slide guide or roller guide integration
Screw fix to side frames
XPSG-6100-TR
- 2 65x16.5mm or 90x16.5mm slat**
Slats held in place with fixing screws
XP-6100-S65 / QS-6100-S90
- 3 Centre support rail**
Affixes to backside of gate slats
Screw fix each slat for extra support
Snap on cover hides all screws
XP-5800-CSR
- 4 Top/bottom plate for centre support rail**
Connects centre support rail to top and bottom rail for extra rigidity
XP-BTP
- 5 Gate insert**
Snaps into gate side frame to hide screw fixings
XP-4200-GI
- 6 Gate side frames**
Machined drill holes
XP-4200-GSF09 or XP-4200-GSF20
- 7 Gate frame screws**
12 gauge x 65mm long with flange hex head
Heavy duty screw fixing of side frame to top/bottom rail
XP-SCREWSGF-10PK
- 8 Gate frame cap**
Presses into top of gate frames
XP-GFC
- 9 Non-punched gate infill**
Replaces slotted infill from gate side frame
XP-XBAT-4200-INF
- 10 Quickscreen side frame**
Affix to inner face of gate side frame
Insert and screw off each slat
Variable slat spacing
QS-5800-SFC
- 11 Quickscreen concealed fixing cover**
Snap-on cover to hide slat fixing screws
QS-5800-CFC
- 12 Fixing screws**
Use to affix side frames and slats
All slats must be screw fixed to side frames
XP-SCREWS
- 13 Bottom Rail**
Bottom rail features underside cavity for easy wheel recess fitting
Screw fixes to side frames
XPSG-6100-BR
- 14 Sliding gate wheel**
80mm diameter wheel with 20mm diameter groove
XPSG-WHEEL
- 15 Wheel clamping set**
Clamps gate wheel to bottom rail
XPSG-WHEEL-CS
- 16 Gate track**
Bolt down track with 20mm diameter running surface – Steel or aluminium
Consider anchor pins to secure track
XPSG-3000/6000-TRACK-ST or XPSG-6000-TRACK-AL

SLIDING GATE OPTIONS

Option 3

Vertical slat gate with 65mm or 90mm x 16.5mm slats
Variable slat spacing including nil spacing

SEE PAGES 91-97 FOR FULL
SPECIFICATIONS ON ALL
PRODUCTS LISTED BELOW

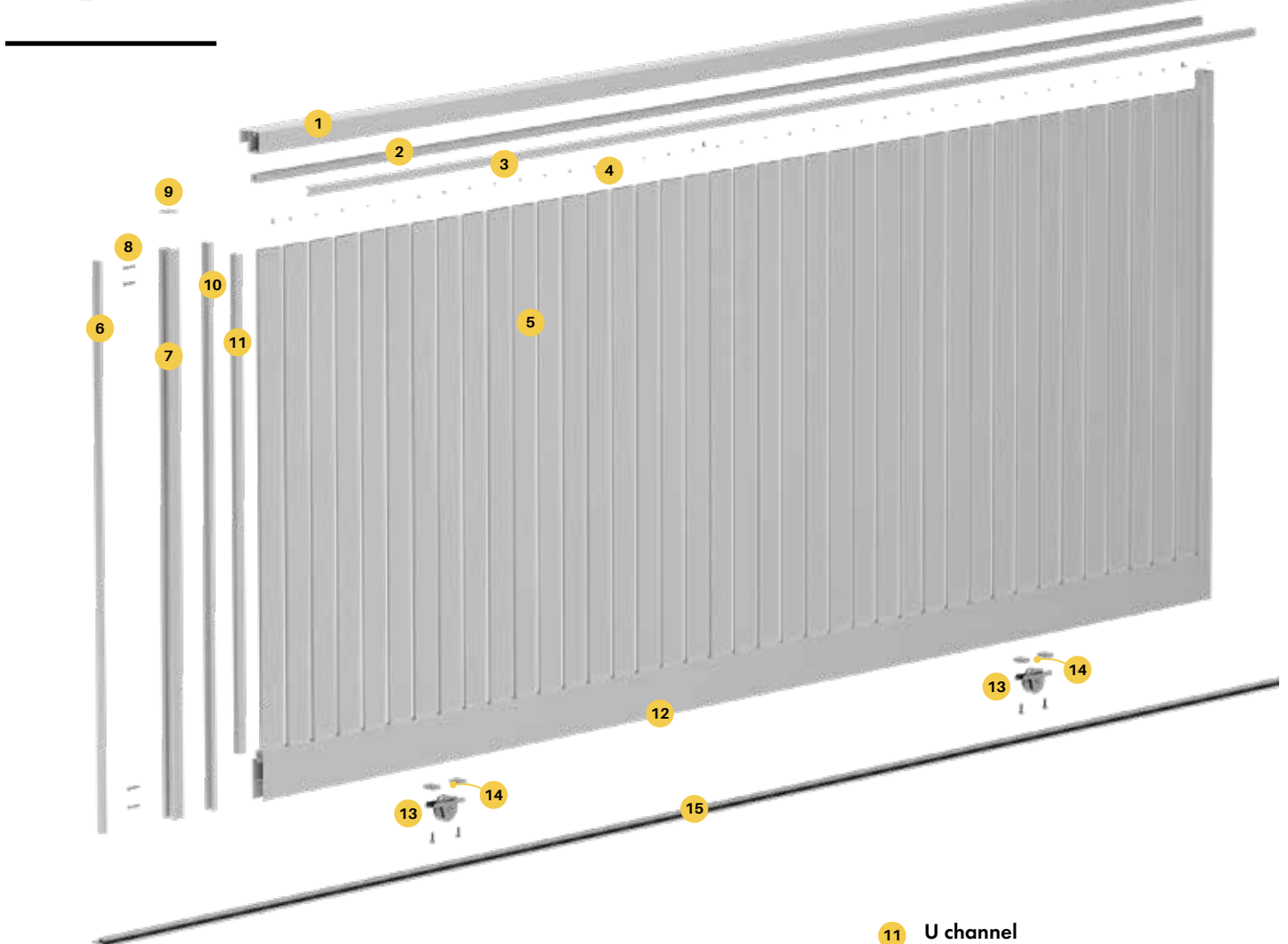

- | | | |
|--|--|--|
| <p>1 Top rail
Rail includes innovative side channel for slide guide or roller guide integration
Screw fix to side frames
XPSG-6100-TR</p> | <p>6 Gate insert
Snaps into gate side frame to hide screw fixings
XP-4200-GI</p> | <p>11 U channel
Affix to vertical inner face of gate side frames. Reduces potential light gap on both vertical edges of gate
QS-5000-HORIZ</p> |
| <p>2 Quickscreen side frame
Affix to inner face of top/bottom rails
Insert and screw off each slat – variable spacing
QS-5800-SFC</p> | <p>7 Gate side frames
Machined drill holes
XP-4200-GSF09 or XP-4200-GSF20</p> | <p>12 Bottom Rail
Bottom rail features underside cavity for easy wheel recess fitting
Screw fixes to side frames
XPSG-6100-BR</p> |
| <p>3 Quickscreen concealed fixing cover
Snap-on cover to hide slat fixing screws
QS-5800-CFC</p> | <p>8 Gate frame screws
12 gauge x 65mm long with flange hex head
Heavy duty screw fixing of side frames to top/bottom rail
XP-SCREWSGF-10PK</p> | <p>13 Sliding gate wheel
80mm diameter wheel with 20mm diameter groove
XPSG-WHEEL</p> |
| <p>4 Fixing screws
Use to affix side frames and slats
All slats must be screw fixed to side frames
XP-SCREWS</p> | <p>9 Gate frame cap
Presses into top of gate frames
XP-GFC</p> | <p>14 Wheel clamping set
Clamps gate wheel to bottom rail
XPSG-WHEEL-CS</p> |
| <p>5 65x16.5mm or 90x16.5mm slat
Slats held in place with fixing screws
XP-6100-S65 / QS-6100-S90</p> | <p>10 Non-punched gate infill
Replaces slotted infill from gate side frame
XP-XBAT-4200-INF</p> | <p>15 Gate track
Bolt down track with 20mm diameter running surface – Steel or aluminium
Consider anchor pins to secure track
XPSG-3000/6000-TRACK-ST or XPSG-6000-TRACK-AL</p> |

When calculating even spacing between vertical slats, overall gate width should be carefully considered to ensure first and last gap (between gate side frames and first/last slat) are kept uniform with other slat spacing

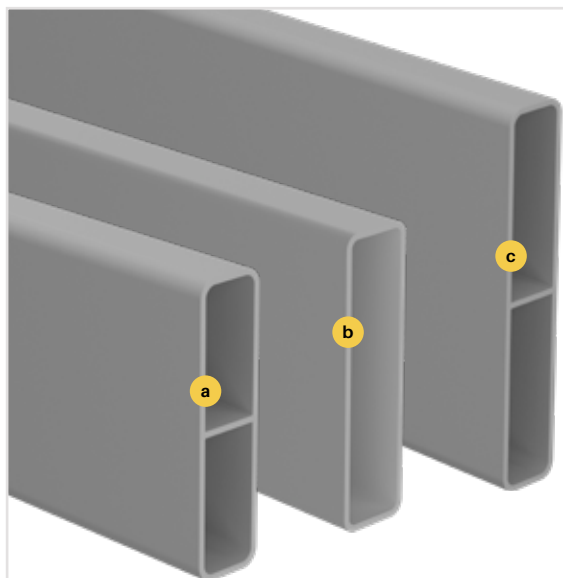

SLAT OPTIONS —

For full slat specification, see pages 7 & 25

- a** 65x16.5mm slat with centre web
- b** 65x16.5mm econo slat
- c** 90x16.5mm slat with centre web



Sliding gate top rail

6100MM LONG

Order Code: XPSG-6100-TR

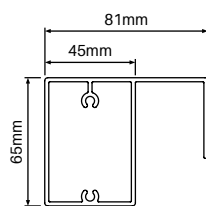

TECH SPECS

- PP 293 / AP 367
- Alloy 6063 T5 / 6100mm long
- 2.5mm wall thickness
- Top rail with innovative side channel for slide guide or roller guide integration
- Screw flutes incorporated for non-weld assembly
- lxx = 513.99 x 10E3 mmE4
- lyy = 404.97 x 10E3 mmE4

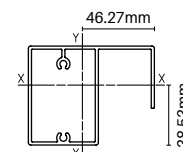

Finishes

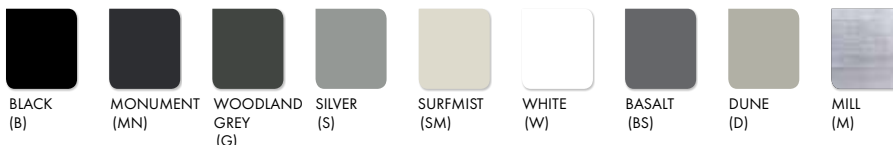

Sliding gate bottom rail

6100MM LONG

Order Code: XPSG-6100-BR

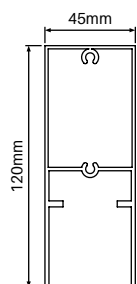

TECH SPECS

- PP 332 / AP 476
- Alloy 6063 T5 / 6100mm long
- 1.8mm wall top section with 2.5mm wall thickness bottom legs
- Bottom rail with underside cavity for wheel recess fitting
- Screw flutes incorporated for non-weld assembly
- lxx = 265.22 x 10E3 mmE4
- lyy = 994.41 x 10E3 mmE4

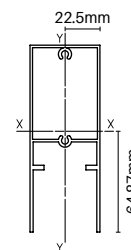

Finishes



GATE EXTRUSIONS



PATENTED FRICTION FIT SYSTEM

9MM SPACING Slotted gate side frame

4200MM LONG

Order Code: XP-4200-GSF09

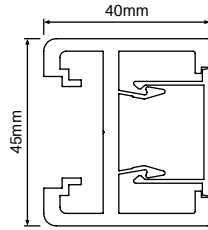

Finishes



TECH SPECS

- PP 170
- Alloy 6063-T5 / 4200mm long
- 3mm wall thickness with 3.8mm centre crossmember
- Slotted insert to suit 65x16.5mm slat with 9mm spacing
- Patented frame for friction insertion of slats
- Crossmember machined with drill holes along entire length to suit screw fixing of top & bottom rail as well as centrally located 'gate' slat
- lxx = 6.294 x 10E3 mmE4
- lyy = 152.403 x 10E3 mmE4

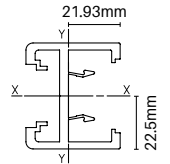

PATENTED FRICTION FIT SYSTEM

20MM SPACING Slotted gate side frame

4200MM LONG

Order Code: XP-4200-GSF20

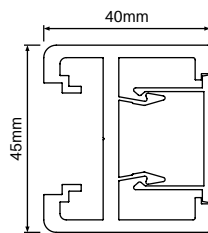

Finishes

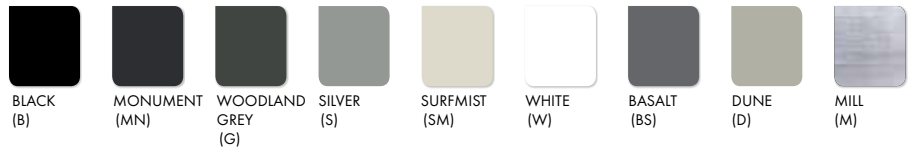

TECH SPECS

- PP 170
- Alloy 6063-T5 / 4200mm long
- 3mm wall thickness with 3.8mm centre crossmember
- Slotted insert to suit 65x16.5mm slat with 20mm spacing
- Patented frame for friction insertion of slats
- Crossmember machined with drill holes along entire length to suit screw fixing of top & bottom rail as well as centrally located 'gate' slat
- lxx = 6.294 x 10E3 mmE4
- lyy = 152.403 x 10E3 mmE4

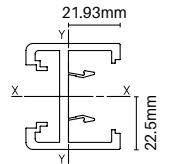

Snap-in gate insert

4200MM LONG

Order Code: XP-4200-GI

MATES WITH XP-4200-GSF09/20

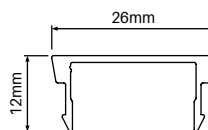

Finishes



TECH SPECS

- PP 100 / AP 100
- Alloy 6060-T5 / 4200mm long
- Snap-in gate insert mates with gate side frame
- Hides screws required for fixing of top & bottom rail and 'gate' slats
- lxx = 0.86 x 10E3 mmE4
- lyy = 5.93 x 10E3 mmE4

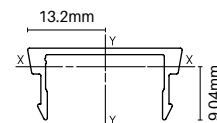

GATE EXTRUSIONS



NON-PUNCHED Gate infill

4200MM LONG

Order Code: XP-XBAT-4200-INF

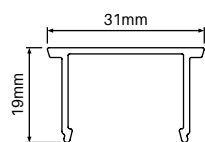

TECH SPECS

- PP 100 / AP 133
- Alloy 6060-T5 / 4200mm long
- Non-punched snap-in infill for gate side frames
- Required when making vertical slat sliding gates, variable spaced horizontal slat gates or gates using 90mm x 16.5mm slats
- Replace existing slotted infill in gate side frame with non-punched gate infill if required
- lxx = 2.94 x 10E3 mmE4
- lyy = 9.50 x 10E3 mmE4

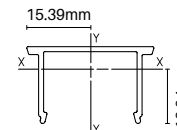

Finishes



BLACK
(B)



MONUMENT
(MN)



WOODLAND
GREY
(G)



SILVER
(S)



SURFMIST
(SM)



WHITE
(W)



BASALT
(BS)



DUNE
(D)



MILL
(M)



Quickscreen side frame

5800MM LONG

Order Code: QS-5800-SF

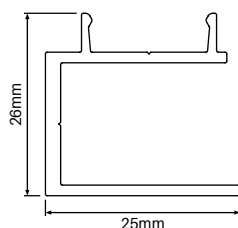

TECH SPECS

- PP 104 / AP 156
- Alloy 6063-T6 / 5800mm long
- Used for sliding gates with horizontal variable slat spacing and vertical slat sliding gates
- Each slat must be screw fixed to side frame
- Affix side frame to 45mm x 40mm gate frame
- lxx = 9.58 x 10E3 mmE4
- lyy = 8.38 x 10E3 mmE4

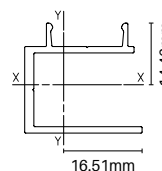

Finishes



BLACK
(B)



MONUMENT
(MN)



WOODLAND
GREY
(G)



SILVER
(S)



SURFMIST
(SM)



WHITE
(W)



BASALT
(BS)



DUNE
(D)



MILL
(M)

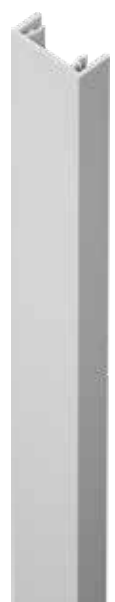

Quickscreen concealed fixing cover

5800MM LONG

Order Code: QS-5800-CFC

MATES WITH QS-5800-SF

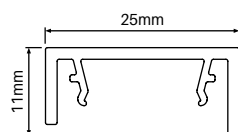

TECH SPECS

- PP 100 / AP 116
- Alloy 6060-T5 / 5800mm long
- Snap-on cover for Quickscreen side frame
- Hides screws used to affix slats to side frame
- lxx = 0.71 x 10E3 mmE4
- lyy = 6.58 x 10E3 mmE4

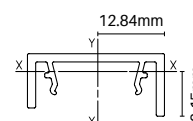

Finishes



BLACK
(B)



MONUMENT
(MN)



WOODLAND
GREY
(G)



SILVER
(S)



SURFMIST
(SM)



WHITE
(W)



BASALT
(BS)



DUNE
(D)



MILL
(M)

GATE EXTRUSIONS



Heavy duty U channel

5000MM LONG

Order Code: QS-5000-HORIZ

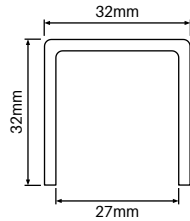

TECH SPECS

- PP 184 / AP 184
- Alloy 6060-T5
- 5000mm long
- 2.5mm wall thickness
- Required for vertical slat sliding gates only. Use on both internal vertical sides to reduce light gaps at gate edges
- lxx = 23.97 x 10E3 mmE4
- lyy = 38.92 x 10E3 mmE4

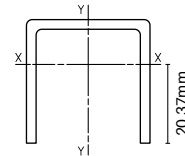

Finishes



65mm x 16.5mm gate slat with centre web & 2x screw flutes

6100MM LONG

Order Code: XP-6100-GB65

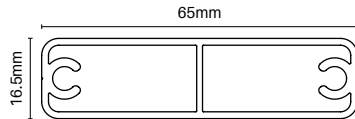

TECH SPECS

- PP 158 / AP 158
- Alloy 6063-T6
- 6100mm long
- 1.5mm wall thickness with 1.2mm wall centre web
- 2x screw flutes
- Used in strategic positions for horizontal sliding gate assembly
- Non weld assembly using 12 gauge screws into screw flutes (Code: XP-SCREWSGF-10PK)
- lxx = 11.85 x 10E3 mmE4
- lyy = 144.09 x 10E3 mmE4

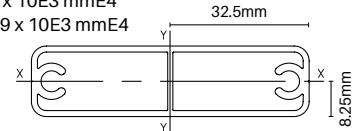

Finishes



Centre support rail

5800MM LONG

Order Code: XP-5800-CSR

OPTIONAL EXTRA

Snap-on cover hides fixings – provides slimline sturdy support rail with no visible fixings

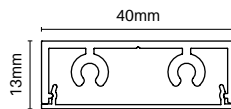

TECH SPECS

- PP 126 / AP 188
- Alloy 6063-T5
- 5800mm long
- Screwing fix centre support rail provides support to slats used in horizontal sliding gates
- For extra rigidity, centre support rail is braced to the top & bottom rail
- lxx = 1.73 x 10E3 mmE4
- lyy = 26.34 x 10E3 mmE4

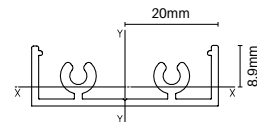

Finishes

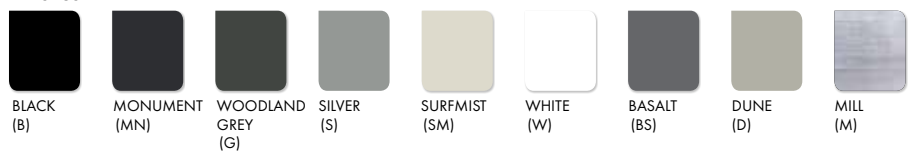

GUIDE POST & EXTENSION

65x65mm steel post

2700MM LONG

Order Code: XPSG-2700-ST65

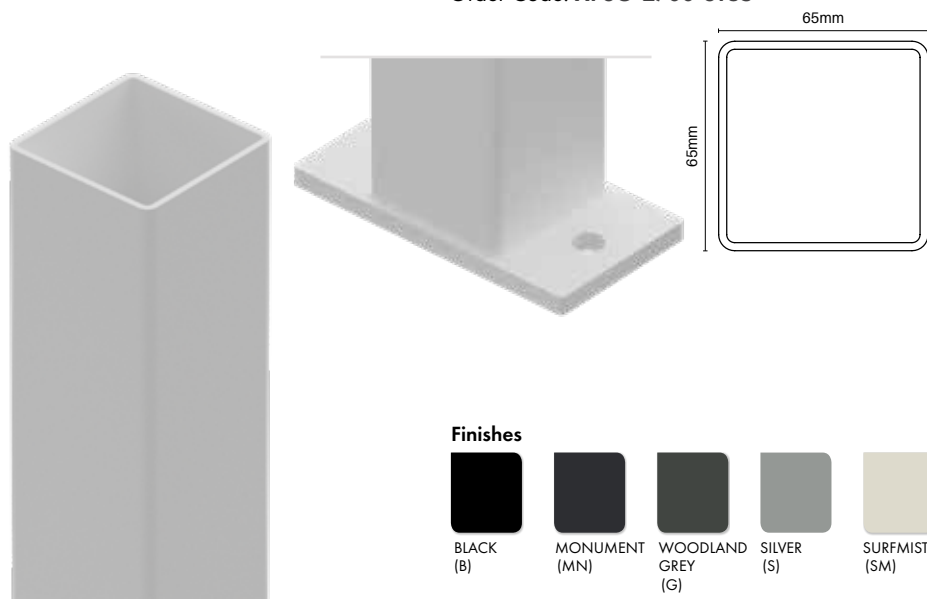

TECH SPECS

- 65x65mm galvanised steel post
- Includes press in black cap
- 2.5mm wall thickness
- Use at gate end to affix guide rollers or slide guide
- May also be used at gate front for affixing U or F catch
- Includes press in black cap
- Includes welded on 8mm thick base plate with 2 x 12.8mm diam fixing holes - use for base plated post fixing or bury into concrete for superior anchoring

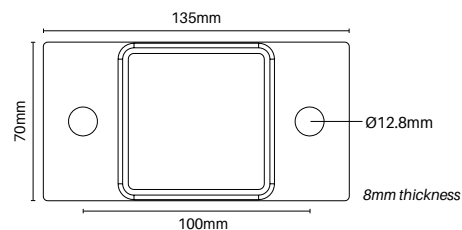

Finishes



Sliding gate extension

400MM LONG

Order Code: XPSG-MXTN-KIT

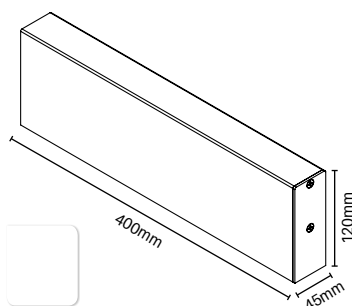

TECH SPECS

- 400mm long bottom rail extension
- Optional extra - useful where extra length required for motor rack to be affixed to bottom rail.
- Not required for every slide gate install. Recommended only where install situation requires
- Extension piece fixes to gate side frame
- Fixing bolts and plates included in kit

Finishes



Simply bolt onto bottom of gate side frame during assembly process

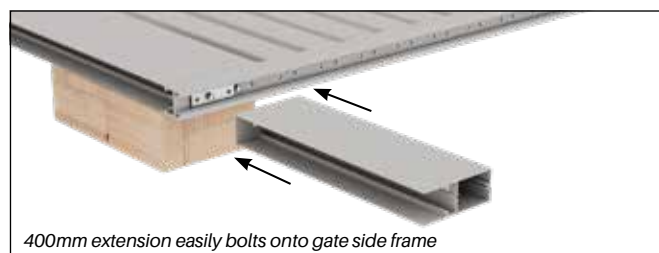

GATE ACCESSORIES

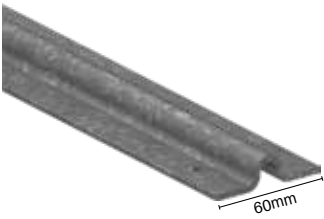

Steel sliding gate track

3000MM LONG OR
6000MM LONG

Order Codes:

XPSG-3000-TRACK-ST (3000mm)

XPSG-6000-TRACK-ST (6000mm)

- Available 3000mm or 6000mm long
- Made from 3mm galvanised steel for durability
- Bolt down sliding gate track with a $\varnothing 20$ mm running surface
- Easy to install with predrilled fixing holes (22 holes for 3000mm track and 42 holes for 6000mm track)

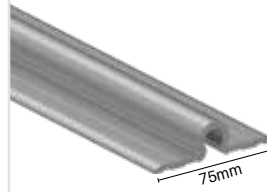

Aluminium sliding gate track

6000MM LONG

Order Code:

XPSG-6000-TRACK-AL (6000mm)

- Available 6000mm long
- Mill finish aluminium - 6063-T5
- Bolt down sliding gate track with a $\varnothing 20$ mm running surface
- No drill holes - drill fixing holes as needed



Sliding gate track pins

Order Code: **XPSG-ANCHOR**

- Mushroom head galvanised steel track anchor pins
- 6.5mm x 38mm
- Pre-expanded expansion anchor. Once hammered in, unique kinked shaft provides a spring action for vibration proof anchoring. Use 6.5mm masonry bit into concrete

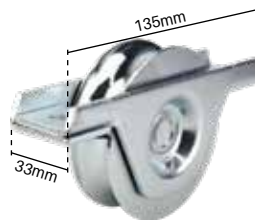

Sliding gate wheel

Order Code: **XPSG-WHEEL**

- 80mm diameter with 20mm diameter groove
- Zinc plated steel
- Load rating 180kg
- Use with 1 x XPSG-WHEEL-CS clamping set to fix to sliding gate bottom rail
- Made in Italy



Sliding gate wheel clamping set

Order Code: **XPSG-WHEEL-CS**

- Use to clamp sliding gate wheel to bottom rail
- Aluminium M8 threaded block
- Includes 2 x zinc plated screws
- Sold as a pack of 2 (suits 1 x wheel)



Slide guide

Order Code: **XPSG-GUIDE**

- Self-adjusting slide guide attaches to sliding gate top rail
- Keeps gate in vertical position and travelling true while opening/closing
- As gate travels along track and shifts up or down, slide guide adjusts automatically. Up to 280mm vertical adjustment.
- Guide channel is anodised black with sturdy nylon block

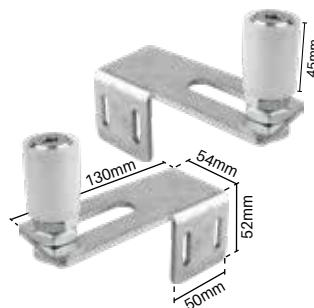

Sliding gate guide rollers

2 PACK

Order Code: **XPSG-TOPROLL-2PK**

- Alternative to SlideGuide
- Rollers guide top rail while gate opens and closes
- Can only be used if vertical deviation of gate while travelling is 15mm or less
- White nylon rollers - made in Italy
- Kit includes 1 x left and 1 x right zinc plated steel mounting bracket (fixings not included) - 30mm hole centers

2 installation methods –

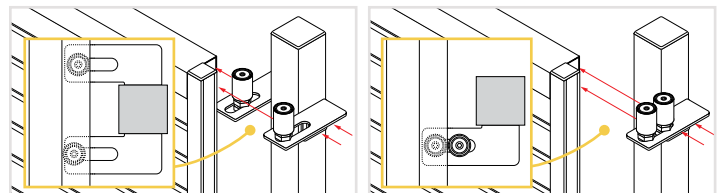

GATE ACCESSORIES



Gate U catch

Order Code: XPSG-CATCH-U

- Suits up to 50mm gate frames
- Gate catch supplied with 5 pre-drilled holes for easy installation and adjustment
- Rubber stop provided for noise reduction
- Steel zinc plated



Gate F catch

Order Code: XPSG-CATCH-F

- Suits up to 50mm gate frames
- Affix bracket to wall/post via "F" leg
- U catch attaches to F section – includes rubber stop for noise reduction
- U catch horizontally adjustable for ease of lining up to gate frame
- Steel zinc plated



Gate stop

Order Code: XPSG-STOP

- Stops the gate in the open position
- Forged steel zinc plated gate stop with nylon bumper
- Bolts to concrete at end of gate track. 4x Ø11mm fixing holes
- Made in Italy



Centre support rail top/bottom plate

Order Code: XP-BTP

- Aluminium with countersunk hole machining
- Use to brace off top and/or bottom of centre support rail to top and bottom rails
- Bracing centre support rail provides extra rigidity

MATES WITH XP-5800-CSR



Gate frame cap

NYLON

Black / Monument / Woodland Grey / Silver / Surfmist / White

Order Code: XP-GFC

- UV stabilised nylon – 3mm thick cap
- Available in 5 colours
- Suits gate side frame
- Press-in flat cap

Finishes



PACK OF 10 Gate frame screws

12Gx65MM HEX FLANGE HEAD

Order Code: XP-SCREWSGF-10PK

- Hex flange head for easy assembly
- Use to screw horizontal top & bottom rails to vertical side frames
- Also use to screw fix 'gate' slat to side frames for horizontal slat gates with 9mm or 20mm spacing (65x16.5mm slats)



Self drilling wafer screws

10Gx16MM – BAG OF 100

Black / Monument / Woodland Grey Silver / Surfmist / White / Basalt Dune / Mill finish

Order Code: XP-SCREWS

- 10G x 16mm self drilling wafer head zinc plated
- Powder coated heads for neat finish
- Use to: (1) Screw fix centre support rail to slats (2) Screw fix & brace off centre support rail top/bottom plate to top/bottom rail (3) Screw fix slats to side frames if required (4) Attach Quickscreen side frame to outer gate frame for gate options 2 & 3 (see pages 89-90)

Sliding gate motors



LONG TERM RELIABILITY
NiceHome automation and accessories are tested every day in the Nice laboratories according to strict criteria. To ensure compliance with the strictest safety requirements on the market, NiceHome guarantees the highest possible technological and quality standards.

PROFESSIONAL QUALITY
Designed and manufactured in Italy, NiceHome automation benefits from unique Italian know-how combining top performance with an essential style to adapt perfectly to the needs of your home.

To complement horizontal slat and vertical slat sliding gates, GO can supply the highest quality Italian made gate automation and accessories. NiceHome automation is a new upgrade to the well-known Mhouse range.



Filo 400 Pro Kit

Order Code: XPSG-FILO-400

- KIT INCLUDES:**
1x Motor
2x Remotes
1x Pair of Photocells (safety device which prevents the gate from closing on pedestrians or vehicles)

- Sliding gate opener suits gates up to 6000mm wide and weighing up to 400kg
- Easy to install and simple programming steps
- Flexible short power cord pre-wired to motor
- Plugs into standard power point with 10 amp flat 3 pin plug
- Includes pinion (cog) that integrates with rack on gate

Low voltage cable option

FILO 400 Pro Kit with split pack Features external transformer

- Order Code: XPSG-FILO-400PRO-SP
- Same motor and accessories as FILO 400 except transformer is separated from motor
 - External transformer converts 240V mains power to low voltage 24V
 - Use 2 core x 2.5mm (double insulated) electrical cable to run from transformer to motor. CABLE SOLD SEPARATELY - can be purchased from electrical wholesaler or reputable hardware store
 - Motor can be installed a maximum of 50 meters away from transformer
 - 10 amp flat 3 pin plug
 - Ideal where getting 240V mains power to gate motor is difficult. Simply run low voltage cable from transformer to gate motor.
 - Refer www.easygate.com.au for technical assistance/manuals

- KIT INCLUDES:**
1x Motor
2x Remotes
1x Pair of Photocells (safety device which prevents the gate from closing on pedestrians or vehicles)
1x External transformer in weatherproof enclosure



External transformer

MOTOR ACCESSORIES



Remote control

Order Code: XPSG-FILO-REMOTE

- Optional extra remote control to replace remotes in kit if broken or more remotes required (2x remotes included as standard with each motor kit)
- 5 channel remote able to control various gate functions (eg open only, close only, partial open etc)



Wireless keypad

Order Code: XPSG-FILO-WKP

- Optional wireless keypad for gate motor opening/closing
- PIN number control access
- Easy to affix to wall or post
- Runs on 2 x CR2430 lithium batteries



Solar power kit

Order Code: XPSG-FILO-SOLAR

- Solar power system designed for use with NiceHome motors
- System uses exclusively solar power to run automation without use of electrical mains power
- Provides continuous electrical energy. Ideal for sites where mains power is unavailable
- Includes photovoltaic panel (converts solar energy into electrical energy) and electric battery (for stored power, able to operate gate night and day)
- Attention must be paid to ensure panel positioned to receive full sunshine



Backup battery

Order Code: XPSG-FILO-BATTERY

- Optional battery provides backup power in the event of mains power failure
- Gate can be cycled multiple times under battery power (no. of cycles may vary due to gate size and site conditions)
- Backup battery is recharged under mains power



Rack

Order Code: XPSG-FILO-RACK

- Tough & durable nylon rack (with steel core)
- Affix to bottom rail of sliding gate
- 1 meter long sections; 6 fixing points
- Quieter than steel racks
- Made in Italy

TECHNICAL ASSISTANCE/MANUALS AND SUPPORT VIDEOS

www.easygate.com.au

ALUMAWOOD

ALUMINIUM SCREENING • KWILA, WESTERN RED CEDAR & ISLAND GREY

INTERPON UNDERCOAT • ITALIAN IMAGE FILM

AUSTRALIA'S BEST QUALITY AT UNBEATABLE PRICES

SYSTEM ADVANTAGES

Concealed fixing: screws are hidden – clean finish!



Low maintenance – unlike timber screening



Cost effective solution



Hinged & sliding gates also available



Adjustable slot spacing





ECO FRIENDLY

Slats have commonly been made from harvested timber which must be repeatedly painted. Alumawood slats are made from aluminium – the most abundant metal in the Earth's crust and third most abundant element (after oxygen and silicon). There are no ongoing painting issues with imaged slats.



FIRE RETARDANT

Aluminium is described as non-combustible. When aluminium is exposed to a prolonged fire environment it will begin to melt (not burn) with a melting point between 600 and 660 degrees celsius. Aluminium slats are an excellent choice where fire risk requires consideration.



WEATHER & INSECT PROOF

Imaged aluminium is impervious to insects and termites plus the non-porous surface is naturally resistant to fungi, mould and mildew. It is also unaffected by exposure to sunlight and water making it ideal for batten/screening solutions.

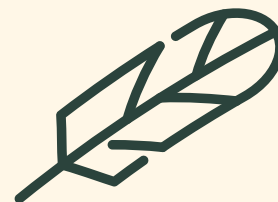

LIGHT WEIGHT

Aluminium weighs approximately one third of a piece of steel that is the same size and shape. Alumawood is made by extruding aluminium which allows for optimisation of shape to maximise strength and reduce weight.



COLOUR STABILITY

Alumawood features genuine Interpon basecoat with Italian film for a long lasting finish.

Woodgrain effect imaged aluminium has a durable base coat applied followed by a technically advanced film which is transferred onto the base coat under heat & pressure. The transfer cannot rub or peel off. The sophisticated process is called sublimation.



RUST PROOF

Aluminium does not rust. Alumawood may be enjoyed for the long term with minimal maintenance and no worry of rusting.

Aluminium is produced to chemical composition, mechanical property and dimensional tolerances in AS/NZS 1866:1997.

- AS/NZS ISO 9001:2008 – Quality Management Systems
- AS/NZS ISO 14001:2004 – Environmental Management Systems
- AS/IEC 17025-NATA – NATA Accredited Mechanical Testing Laboratory

now
available!

ISLAND GREY

ALUMINIUM SLAT SCREENING

WITH MONUMENT POWDER COAT
POSTS & ACCESSORIES

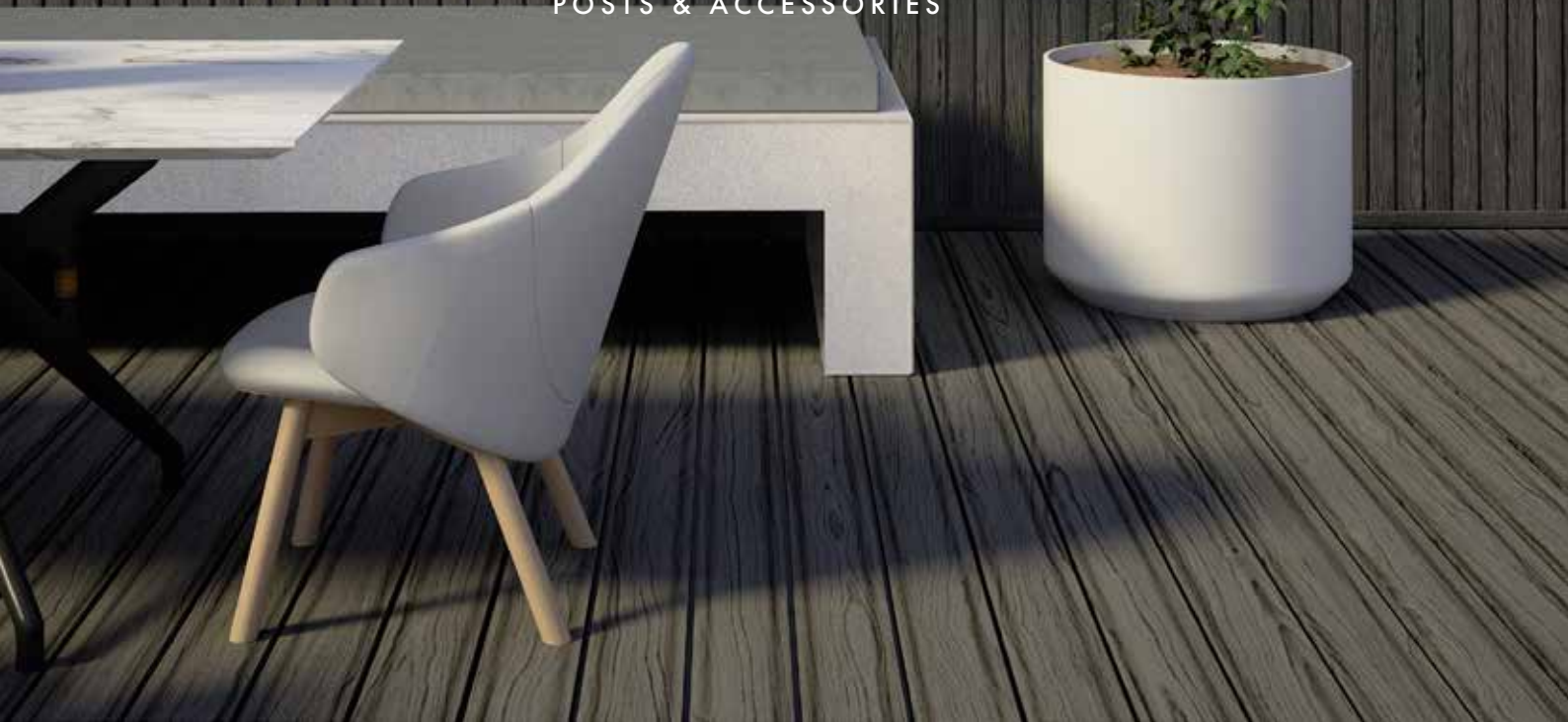

**65mm x 16.5mm slat
with centre web**

5800MM LONG

Order Code: **AW-5800-S65-IG**

- Alloy 6063-T6
- 1.2mm wall thickness with centre web
- Ideal match with Trex™ Island Mist board

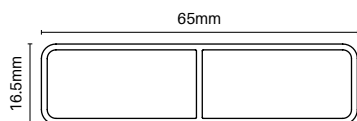

Finishes



ISLAND GREY

Timber imaged aluminium



**65mm x 16.5mm gate
slat with centre web &
2x screw flutes**

5800MM LONG

Order Code: **AW-5800-GB65-IG**

- Required for gate assembly

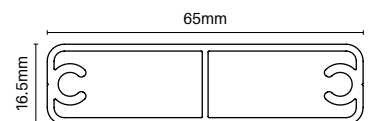

Finishes



ISLAND GREY

SLAT OPTIONS



65mm x 16.5mm slat with centre web

5800MM LONG
Order Code: AW-5800-S65

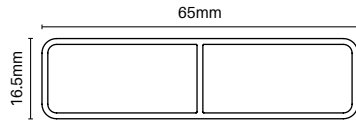

Finishes



TECH SPECS

- PP 157 / AP 157
- Alloy 6063-T6
- 5800mm long
- 1.2mm wall thickness with centre web
- 3.5mm radius corners
- Interpon base coat; Italian image film
- lxx = 9.60 x 10E3 mmE4
- lyy = 83.09 x 10E3 mmE4

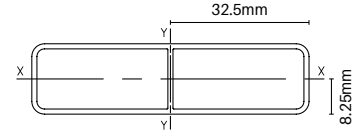

CENTRE WEB ADDS STRENGTH & RIGIDITY TO SLAT



65mm x 16.5mm gate slat with centre web & 2x screw flutes

5800MM LONG
Order Code: AW-5800-GB65

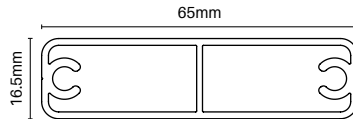

Finishes



TECH SPECS

- PP 158 / AP 158
- Alloy 6063-T6
- 5800mm long
- 1.5mm wall thickness with 1.2mm wall centre web
- 2x screw flutes
- Interpon base coat; Italian image film
- Used in strategic positions for gate assembly
- Non weld assembly using 12 gauge screws into screw flutes (Code: XP-SCREWSGF-10PK)
- lxx = 11.85 x 10E3 mmE4
- lyy = 144.09 x 10E3 mmE4

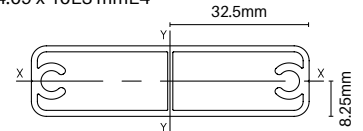

SCREW FLUTES USED IN GATE ASSEMBLY



90mm x 16mm slat with centre web

5800MM LONG
Order Code: AWQS-5800-S90-WRC

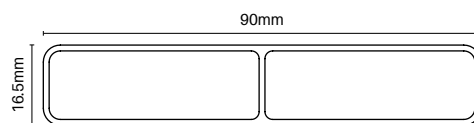

Finishes



TECH SPECS

- PP 208 / AP 208
- Alloy 6063-T6
- 5800mm long
- 1.2mm wall thickness with centre web
- 3mm radius corners
- Interpon base coat; Italian image film
- lxx = 13.28 x 10E3 mmE4
- lyy = 202.57 x 10E3 mmE4

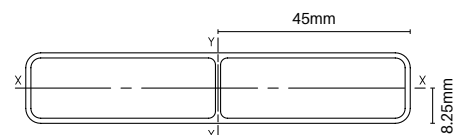

CENTRE WEB ADDS STRENGTH & RIGIDITY TO SLAT

ALUMAWOOD HORIZONTAL SLAT SYSTEM



- For Island Grey*
- 1 Concealed fixing cover**
AWQS-5800-CFC
Refer page 107

 - 2 Side frame**
AWQS-5800-SF
Refer page 107

 - 3 Spacers & screws**
QS-KIT
Refer page 113

 - 4 Side frame top cap**
QS-SFC-B
Refer page 108

 - 5 65x16.5mm or 90x16mm slat**
65mm: AW-5800-S65
90mm: AWQS-5800-S90-WRC*
*WRC finish only
Refer page 103

 - 6 F section**
AWQS-5800-F
Refer page 107

 - 7 135 degree adapter**
AW-5800-135
Refer page 109





POSTS & ACCESSORIES —

- 1 50x50mm post
- 4 Dress rings
- 2 65x65mm heavy duty post
- 5 Domical covers
- 3 Top caps
- 6 Base plates

For full range of posts & accessories, see pages 111 & 112
**Monument powder coat finish to complement Island Grey





ALUMAWOOD SCREENING EXTRUSIONS

The Alumawood system is extremely cost effective. Each slat is screwed off once in position. The system allows for variable slat spacing so any gap is achievable. Once slats are screwed off, a snap on cover hides the fixings to provide a seamless finish.

For horizontal slat screening, generally the side frame is screwed directly to a post or wall without need of another U channel or angle.

In 'void' situations where slats cannot be fed in from top down, an F section is available. The F section can also be used where it is preferred to pre-make complete panels in a factory and simply install onsite.

For raking panels/angles, slats can be cut at an angle and screwed off making Alumawood an ideal solution for difficult installations.

Vertical slat screening is also easily achievable with Alumawood extrusions.

Available in long length supply or custom made to size ready for assembly.

ALUMAWOOD EXTRUSIONS



Side frame

5800MM LONG

Order Code: **AWQS-5800-SF**
QS-5800-SF-MN

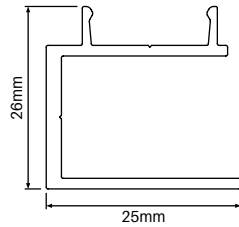

Finishes



KWILA
(KWI)



WESTERN
RED CEDAR
(WRC)



MONUMENT
(MN)
For Island Grey

TECH SPECS

- PP 104 / AP 156
- Alloy 6063-T6 / 5800mm long
- Each slat must be screw fixed to side frame
- For horizontal slat - affix side frame directly to post or wall or use with F-section
- For vertical slat - use as top/bottom frame into which slats are inserted
- Screw fixings are hidden when panel is assembled
- lxx = 9.58 x 10E3 mmE4
- lyy = 8.38 x 10E3 mmE4

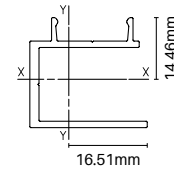

Concealed fixing cover

5800MM LONG

Order Code: **AWQS-5800-CFC**
QS-5800-CFC-MN

MATES WITH AWQS-5800-SF
QS-5800-SF-MN

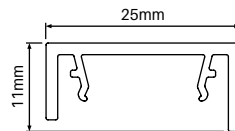

Finishes



KWILA
(KWI)



WESTERN
RED CEDAR
(WRC)



MONUMENT
(MN)
For Island Grey

TECH SPECS

- PP 100 / AP 116
- Alloy 6060-T5 / 5800mm long
- Snap-on cover for Alumawood side frame
- Hides screws used to affix slats to side frame
- Cover not required in vertical slat installs
- lxx = 0.71 x 10E3 mmE4
- lyy = 6.58 x 10E3 mmE4

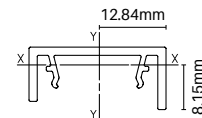

F section

5800MM LONG

Order Code: **AWQS-5800-F**
QS-5800-F-MN

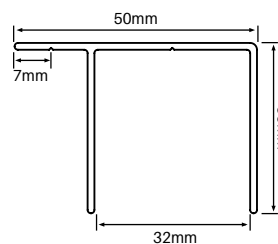

Finishes



KWILA
(KWI)



WESTERN
RED CEDAR
(WRC)



MONUMENT
(MN)
For Island Grey

TECH SPECS

- PP 170 / AP 234
- Alloy 6063-T6
- 5800mm long
- Fix off to wall or post through 15mm offset leg
- For horizontal slat - use in a void situation or if panels pre-assembled in factory for installation onsite
- For vertical slat - use as vertical side frames into which horizontal top/bottom rails are inserted
- 1.4mm wall thickness
- lxx = 20.76 x 10E3 mmE4
- lyy = 42.29 x 10E3 mmE4

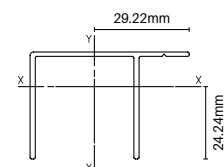

ALUMAWOOD EXTRUSIONS



Heavy duty U channel top/bottom frame

5000MM LONG
Order Code: **AWQS-5000-HORIZ**
QS-5000-HORIZ-MN

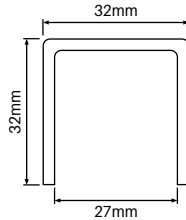

**FOR VERTICAL
SLAT**

Finishes

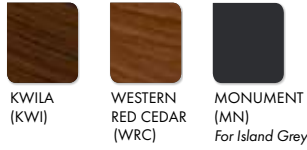

TECH SPECS

- PP 184 / AP 184
- Alloy 6060-T5
- 5000mm long
- For horizontal slat – not required
- For vertical slat – use as top/bottom U channel frame into which frames inserted (refer code AWQS-5800-SF)
- 2.5mm wall thickness
- lxx = 23.97 x 10E3 mmE4
- lyy = 38.92 x 10E3 mmE4

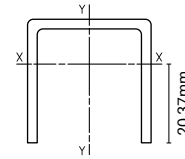

Centre support rail

5800MM LONG
Order Code: **AW-5800-CSR**
XP-5800-CSR-MN

OPTIONAL EXTRA

Commonly used for screens 2000mm or wider to provide strength & rigidity to panel

Snap-on cover hides fixings – provides slimline sturdy support rail with no visible fixings

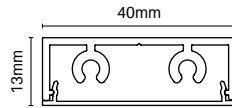

Finishes

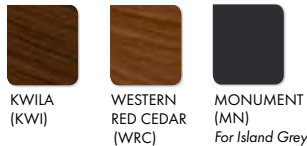

TECH SPECS

- PP 126 / AP 188
- Alloy 6063-T5
- 5800mm long
- Screw fix off to each slat to provide support/rigidity
- For horizontal slat – support rail installed vertically to brace horizontal slats
- For vertical slat – support rail installed horizontally to brace vertical slats
- Includes 2x screw flutes for cap insertion
- lxx = 1.73 x 10E3 mmE4
- lyy = 26.34 x 10E3 mmE4

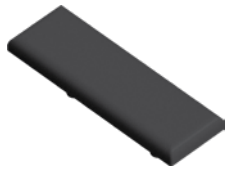
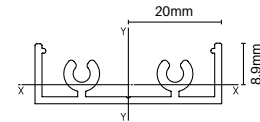

MATES WITH AW-5800-CSR

Centre support rail cap

40mm x 13mm

3MM THICK

Order Code: **XP-CSRC-B**

- Black nylon cap
- Simply press into screw flutes in centre support rail
- Easy and fast fitting of cap



MATES WITH AW-5800-CSR
XP-5800-CSR

Centre support rail top/bottom plate

Order Code: **AW-BTP-TR**
XP-BTP-MN

- Optional extra to install as part of centre support rail
- Aluminium with countersunk hole machining
- Terrain powder coat finish matches well with Kwila & WRC finishes
- Monument powder coat matches with Island Grey
- 2x CSK screws included for fixing to CSR
- Use to brace top and/or bottom of centre support rail to structure above or below if desired
- Bracing centre support rail provides extra rigidity to panels – recommended for wide screens



MONUMENT (MN)
For Island Grey

Side frame top cap

30mm x 26mm

3MM THICK

Order Code: **QS-SFC-B**

- Black nylon cap
- Simply press into side frame
- Easy and fast fitting of cap

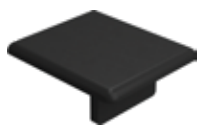

MATES WITH
AWQS-5800-SF
+
AWQS-5800-CFC



Screw top/bottom plate to centre support rail



Screw through central hole to substrate at top or bottom

ALUMAWOOD 135 ANGLE ADAPTER

135 degree adapter

5800MM LONG

Order Code: AW-5800-135

XP-6000-135-MN



TECH SPECS

- PP 109 / AP 163
- Alloy 6060 - T5
- Simple 2 step process:
 - (1) Adapter simply fixes to post/wall.
 - (2) Quickscreen side frame then attached to adapter into which slats insert
- Ideal for when screens to run at 135 degree angle from post or wall
- lxx = 5.76 x 10E3 mmE4
- lyy = 25.92 x 10E3 mmE4

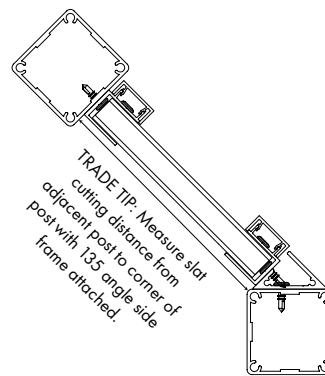
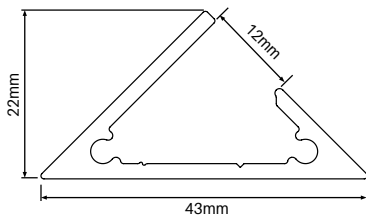
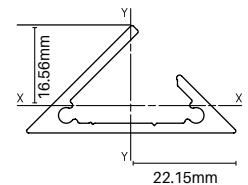

Finishes



KWILA (KWI)



WESTERN RED CEDAR (WRC)



MONUMENT (MN)
For Island Grey

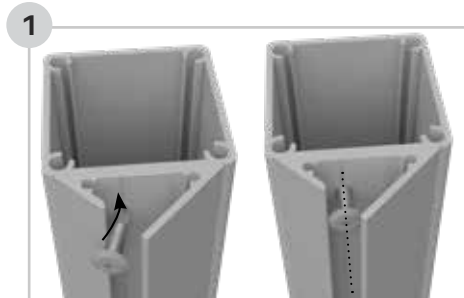

Place 135 adapter against post/wall. Insert screw into void opening. Screw fix adapter using V groove as a guide to fixing location.
TIP: pilot hole drill before screw fixing; max screw head size is 10mm.

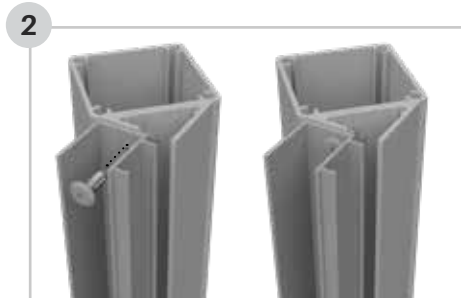

Screw fix Quickscreen Side Frame with screw positioned slightly offset from centre (closer to the snap on cover side) but ensure screw sufficiently engages with short leg of 135 angle adapter.

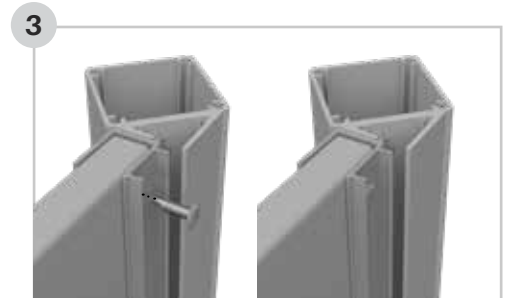

Insert slats into Quickscreen side frame and fix off slats.

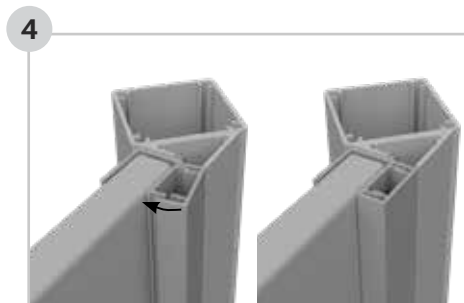

Snap on concealed fixing cover. Lever into place with short leg going on first then levering on long leg to snap into position.

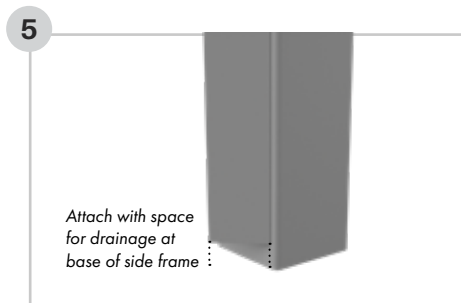

135 angle adapter should be cut so that it is elevated from floor and at the same length as Quickscreen Side Frame.

NOW AVAILABLE HORIZONTAL SLAT BALUSTRADE



Four stylish infill designs to choose from



Save time & money without compromising quality or style



Non-weld assembly and easy installation



Engineering certification approved for balustrading

Why choose horizontal slat balustrade?

AIRE Horizontal Slat Balustrade is a complete non-weld system which perfectly typifies the saying 'simplicity is the ultimate form of sophistication'. With sleek lines and innovative design consideration ensuring screw fixings are hidden, the system is easy to install and yet provides for a stunning finish.

The system is stocked in 3 popular powder coat finishes – satin black, monument matt and pearl white glass. It is also available in mill finish allowing customisation of powder coat colour. Pre-powder coated material can be cut to required lengths and assembled onsite. The installation process is simple and effective – side frames are affixed to the sturdy aluminium posts and horizontal slats are screw fixed either side with a fixing cover hiding screws.

The system has been extensively load tested by accredited NATA testing facilities. Importantly, engineering compliance certification is available.

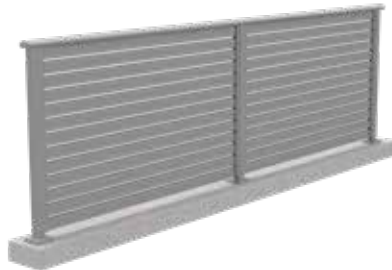

01

Horizontal Slat Balustrade

Horizontal slat balustrade with 9mm spacing with welded base plated posts

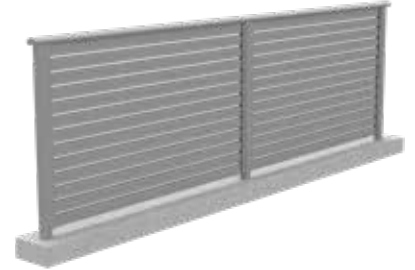

02

Horizontal Slat Balustrade

Horizontal slat balustrade with 9mm spacing with core drill posts

POSTS & ACCESSORIES

50x50mm full post

2400MM, 5800MM or 6000MM LONG
Order Code: **AW-2400/5800-FP**
XP-2400/6000-FP-MN

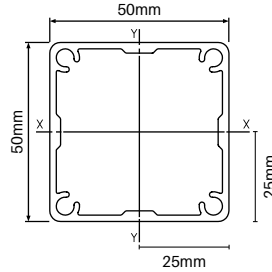

Finishes



TECH SPECS

- Alloy 6063 - T6
- 1.8mm wall thickness with 3mm ribs
- Screw flutes to screw on base plate if required
- Press-in aluminium powder coated top plate included with 2400mm posts
- lxx = 170.44 x 10E3 mmE4
- lyy = 170.44 x 10E3 mmE4

4x screw flutes in post allow tight fit of press in flat aluminium top plate.

Optional base plate can be attached using screw flutes for base plated post installations.



50x50mm post flat top plate

POWDER COATED ALUMINIUM

Order Code: **AW-TP-TR / XP-TP-MN**

- Alloy ADC12 aluminium plate
- Powder coated to complement image finish
- Press into post screw flutes for secure fixing
- Suits 50 x 50mm post
- 2400mm posts come with free top plate included - only purchase if extra top plates are required
- Top plates required for 5800mm/ 6000mm posts - sold separately

Powder coat colour

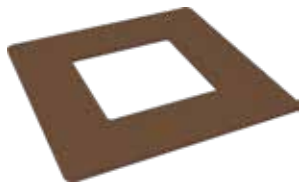

50x50mm post dress ring

POWDER COATED ALUMINIUM

Order Code: **AW-DR-TR / XP-DR-MN**

- Suits 50x50mm core drill posts
- Terrain powder coat suits both Kwila & WRC image finishes
- 100mm x 100mm outer - 52mm x 52mm inner

Powder coat colour

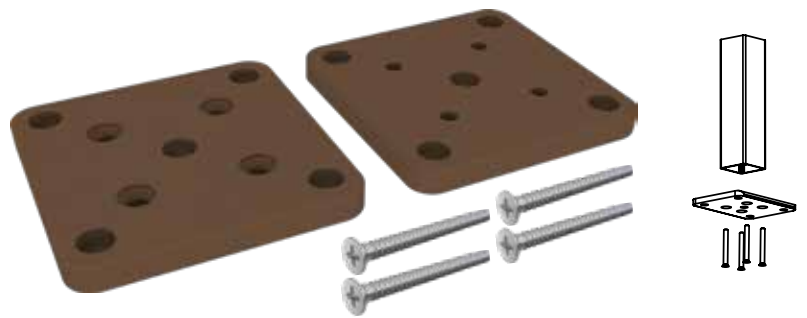

50x50mm post base plate set

POWDER COATED ALUMINIUM

Order Code: **AW-BP-SET-TR**
XP-BP-SET-MN

- Simply screw base plate onto core drill post
- 4x 12G x 50mm long CSK screws included in set

Powder coat colour

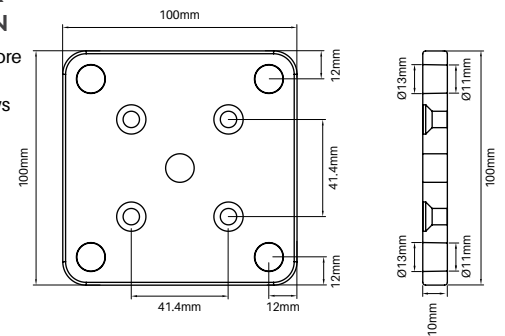

Discreet screws fix two parts of cover together

Powder coat colour



Two part domical cover

POWDER COATED ALUMINIUM

Order Code: **AW-DC-2P-TR**
XP-DC-2P-MN

- Suits 50x50mm post with screw fixed base plate
- Terrain powder coat matches well with Kwila & WRC image finish
- 106x106mm outer - 52x52mm inner - Alloy ADC12
- 29.5mm high
- Cover can be fitted to posts after fence is installed with innovative 2 piece design

POSTS & ACCESSORIES

65x65mm heavy duty post

2400MM, 5800MM or 6000MM LONG
Order Code: **AW-2400/5800-65HD**
XP-2400/6000-65HD-MN

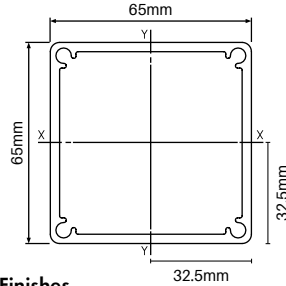

Finishes



TECH SPECS

- 65x65mm larger profile, heavy duty post
- Alloy 6063 - T6
- 3mm wall thickness
- Screw flutes to screw on base plate if required
- Aluminium powder coated press-in top plate included with 2400mm posts
- lxx = 464.62 x 10E3 mmE4
- lyy = 464.62 x 10E3 mmE4

4x screw flutes in post allow tight fit of press in flat aluminium top plate.

Optional base plate can be attached using screw flutes for base plated post installations.



65x65mm post flat top plate

POWDER COATED ALUMINIUM

Order Code: **AW-65TP-TR / XP-65TP-MN**

- Alloy ADC12 aluminium plate
- Coated to complement image finish
- Press into post screw flutes for secure fixing
- 2400mm posts come with free top plate included - only purchase if extra top plates are required
- Top plates required for 5800mm/ 6000mm posts - sold separately

Powder coat colour

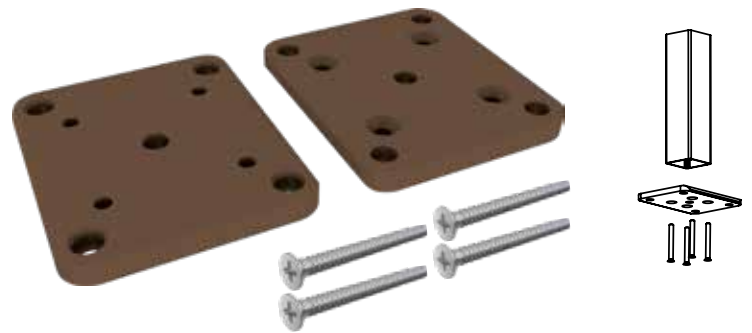

65x65mm post base plate set

POWDER COATED ALUMINIUM

Order Code: **AW-65BP-SET-TR / XP-65BP-SET-MN**

- Simply screw base plate onto core drill post
- 4x 12G x 50mm long CSK screws included in set

Powder coat colour

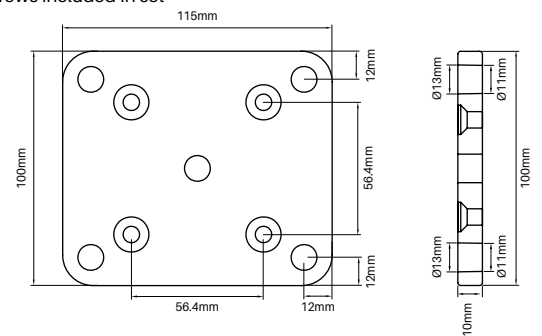

65x65mm post dress ring

POWDER COATED ALUMINIUM

Order Code: **AW-65DR-TR / XP-65DR-MN**

- Suits 65x65mm heavy duty post
- Terrain powder coat suits both Kwila & WRC image finishes
- 115mm x 115mm outer - 67mm x 67mm inner

Powder coat colour



65x65mm two part domical cover

POWDER COATED ALUMINIUM

Order Code: **AW-65DC-2P-TR**
XP-65DC-2P-MN

- Suits 65x65mm post with screw fixed base plate
- 122x106mm outer - 67x67mm inner - Alloy ADC12
- 30mm high
- Cover can be fitted to posts after fence is installed

Powder coat colour

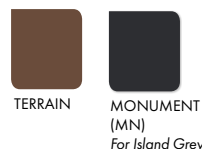

ACCESSORIES



Timber fixing kit

4 PACK – SS316
Order Code: S-110LAG-4PK

- M10 x 110mm timber lag screws x4 with nuts and washers
- Suits fixing holes in both the 50x50mm and 65x65mm base plate sets



Concrete fixing kit

4 PACK – SS316
Order Code: S-120ROD-4PK

- M10 x 120mm concrete threaded rods x4 with nuts and washers
- Suits fixing holes in both the 50x50mm and 65x65mm base plate sets



Screw & spacer kit

SCREWS & SPACER BLOCKS
Order Code: QS-KIT

- 50 screws: 10G x 18mm long
- 10x spacer blocks
- Spacers enable 9mm, 15mm or 20mm spacing between slats
- Use screws to fix off slats
- Remove spacers once slats are screw fixed off

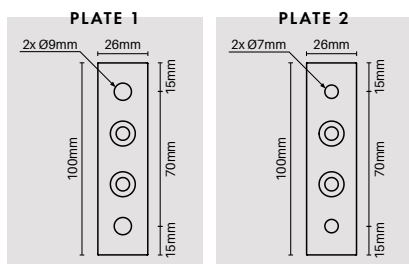
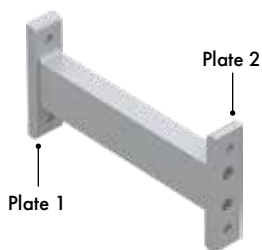

Side frame mounting arm

200MM or 400MM WIDE

Black / Monument / Woodland Grey
Silver / Surfmist / Mill finish

Order Code: XP-ARMSF (200mm wide)
XP-ARMSF-400-M (400mm wide – Mill finish)

- Use for mounting screens offset from a vertical surface
- 2x welded fixing plates – 100mm L x 26mm W x 10mm D
- 2x Ø9mm fixing holes (plate 1) & 2x 7mm fixing holes (plate 2)

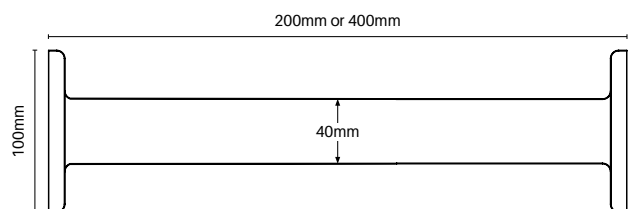

Louvre brackets

1x LEFT & 1x RIGHT
Terrain

Order Code: AW-LB-TR / QS-LB-MN

- 1x left and 1x right bracket per pack
- Terrain powder matches well with Kwila & WRC image finishes
- Monument powder coat matches well with Island Grey
- Die cast aluminium
- Suits 65x16.5mm slat – Press brackets onto end of slat then insert bracket into side frame
- Space brackets at nil, 5, 9, 20mm or any spacing desired
- Cost effective and fast way to achieve a fixed louvre finish



MONUMENT (MN)
For Island Grey

40° FINAL SLAT ANGLE

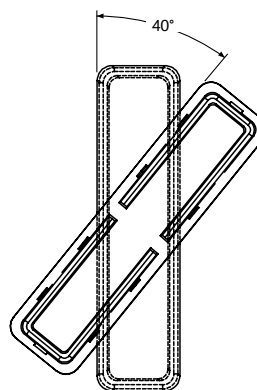

100mm support foot

HEIGHT ADJUSTABLE
SS316 / POLISH FINISH

Order Code: XP-FOOT-ADJ

- Height adjustable support foot for wider or larger screens
- Screw fix to midpoint of underside of bottom rail U channel
- Easily height adjustable (from 25mm up to 100mm) – stainless steel stem can be cut down and bottom flange reattached with grub screw
- Stylish high polish marine grade SS316 finish

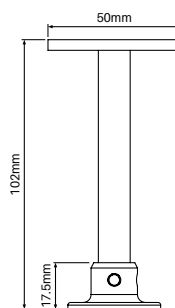

Remove stem from base plate and cut to required length

ACCESSORIES

65MM SLAT CAPS

Suits 65x16.5mm slats
Order Code: AW-EC65-TR-4PK
XP-EC65-MN-4PK



Powder coat colour



TECH SPECS

- Alloy ADC12 aluminium flat end cap
- Suits GO's 65x16.5mm slat
- Terrain powder coat finish suits Kwila & WRC slats
- Monument powder coat finish matches well with Island Grey slats
- Press into end of slat
- Innovative design feature with polymer inserts ensures tight press in fit (inserts supplied with every cap)
- Internally slotted so end cap can be used with webbed or non-webbed slats

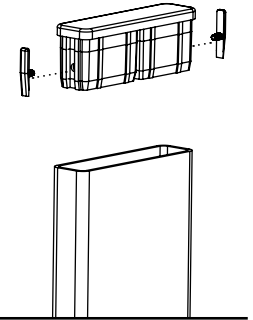

DESIGN INNOVATION

Tapered polymer insert can be installed one or both sides of cap.
Use inserts if cap not a tight fit in slat.

90MM SLAT CAPS

Suits 90x16mm WRC slats only
Order Code: AW-EC90-TR-4PK



Powder coat colour



TECH SPECS

- Alloy ADC12 aluminium flat end cap
- Suits GO's 90x16mm slat
- Terrain powder coat finish suits WRC slats
- Press into end of slat
- Innovative design feature with polymer inserts ensures tight press in fit (inserts supplied with every cap)
- Internally slotted so end cap can be used with webbed or non-webbed slats
- Sold as a 4 pack



Rapid set concrete

20KG BAG
Order Code: GROUT-RSC

- Specially formulated to harden rapidly
- Not available Perth depot - Use 20kg Kwik Set concrete (Code: GROUT-KWIKSET)



Kwikset concrete
Perth only



Concrete mix

20KG BAG
Order Code: GROUT-CONCRETE

- Quality blend of GP cement, aggregate & sand - just add water
- Ideal for high strength concreting of posts



Sika HES grout

20KG BAG
Order Code: GROUT-SIKA

- Non shrink structural grout
- Ready mixed, high quality grout
- Sets with high early strength



Bostik HES grout

20KG BAG
Order Code: GROUT-BOS

- Non shrink structural grout
- High performance, high early strength

ACCESSORIES

STAINLESS STEEL FASTENERS



M12 dome nut

PACK OF 4 – SS316

Order Code:
GS-DN-4PK

- 4x dome nuts & 4x split washers
- Suits M12 thread

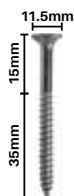

50mm CSK batten screw

SS316
14 gauge
Order Code:
CSK-050



75mm CSK batten screw

SS316
14 gauge
Order Code:
CSK-075

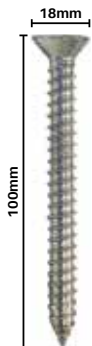

100mm CSK timber screw

4 PACK – SS316
M12 thread
Order Code:
CSK-100-4PK

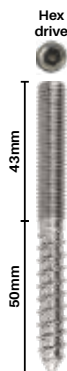

93mm lag screw

SS304
M12 thread
Order Code:
GS093LAG



115mm lag screw

SS304
M12 thread
Order Code:
GS115LAG



160mm lag screw

SS304
M12 thread
Order Code:
GS160LAG

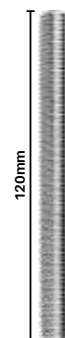

120mm threaded rod

SS304
M12 thread
Order Code:
GS120ROD

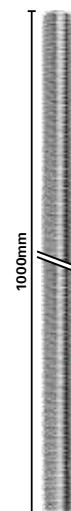

1000mm threaded rod

SS304
M12 thread
Order Code:
GS1000ROD



Self drilling tek screws

12Gx20mm – BAG OF 100

Black, Woodland Grey, Monument, Primrose, Paperbark, Silver, Surfmist & White

Order Code: SS-TS-100

- Self drilling tek screw featuring integrated thread and drill/cutting tip
- 12G x 20mm tek screw with hex head
- Packed in convenient bags of 100 screws



Soudafix CA1400 Chemical anchor

280mL

Order Code: SOUD-CA1400

- High performance, two-component chemical anchoring resin for the pressure-free securing of anchoring rods, studs, threaded collars etc
- Fast cure
- Vinyl ester styrene free
- Can be used in damp concrete
- Apply with standard caulking gun



Self drilling wafer screws

10Gx16mm – BAG OF 100

Black / Monument / Woodland Grey / Mill finish

Order Code: XP-SCREWS

- Bags of 100 – 10G x 16mm self drilling wafer head zinc plated
- Powder coated heads for neat finish
- Ideal for fixing top/bottom frame to F section
- Can also be used for fixing slats to top/bottom frame with vertical slat screening

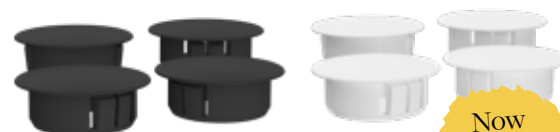

Post plugs – 4 pack

Black or White finish

Order Code: SS-POSTPLUG-4PK
SS-POSTPLUG-4PK-W

- Ø32mm outer top suits 25mm hole
- Suits post wall thickness 1.5mm – 3.2mm
- Cap holes in posts when fixing posts to structures

Now available in white!

HORIZONTAL SLAT INSTALL GUIDE

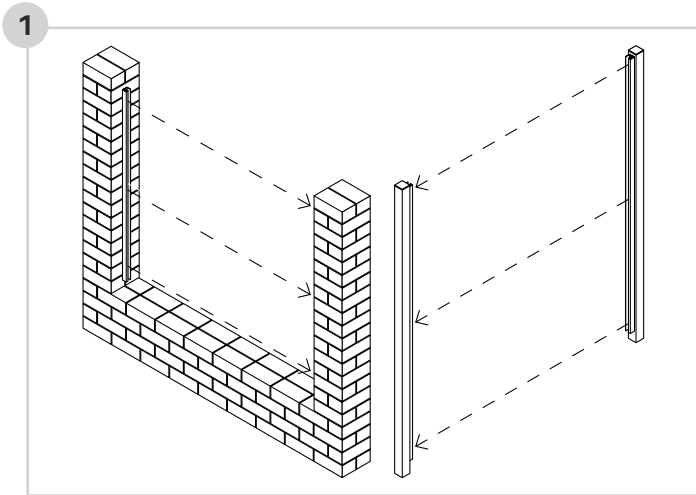

1 Take measurement between walls or posts at 3 points: top, middle and bottom (Take note of the smallest measurement)

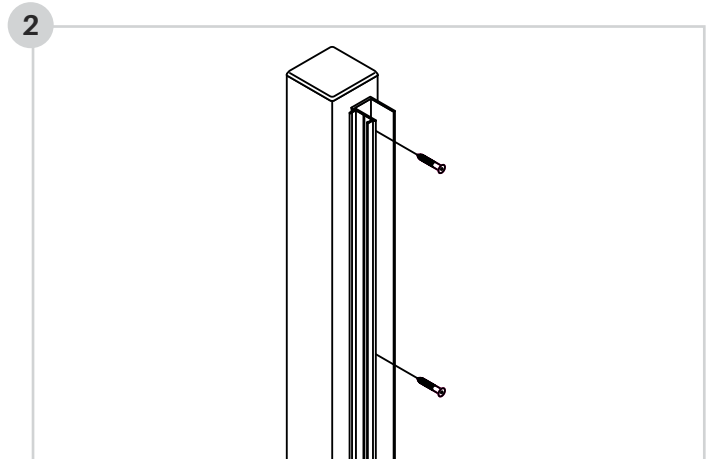

2 Cut side frames 3mm less than desired height (3mm allows for the top cap)
Affix side frames to wall or post with appropriate fixings

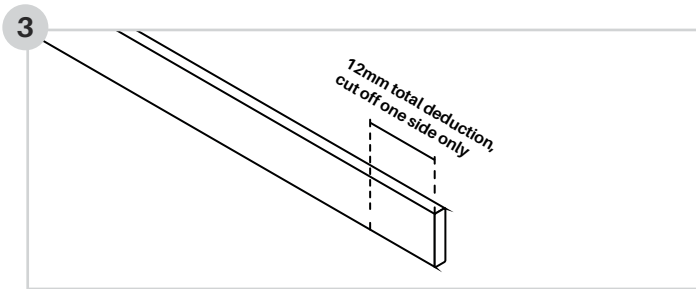

3 Cut aluminium slats 12mm less than total width of opening (Refer to measurement in step 1)

The 12mm deduction takes into account thickness of side frame on both sides of the screen and head of fixings.

Ensure fixings holding side frame do not obstruct slats when dropping in. If so, you may need to trim slats further.

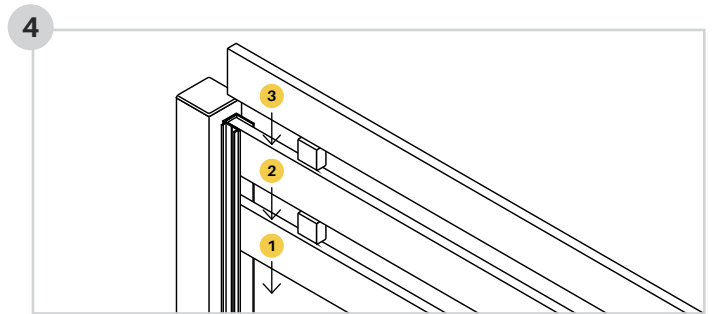

4 Drop in aluminium slats

Tip: Ensure bottom slat is level and screw off at both sides

Optional spacer blocks can be rotated to achieve a 9, 15 or 20mm slat gap. Any gap can be achieved by leaving a desired space. Consider using timber block spacers to achieve other gaps.

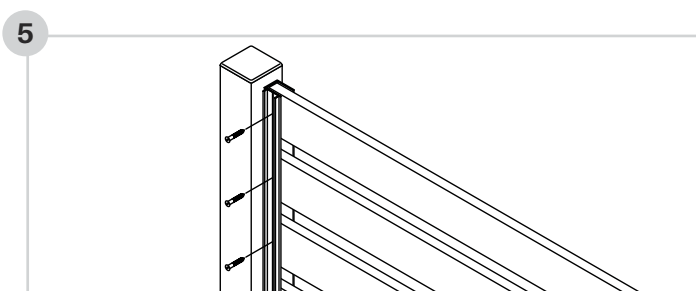

5 Screw off each slat as it is dropped in (ensuring each slat is level)
If spacer blocks used, remove after each level is installed.

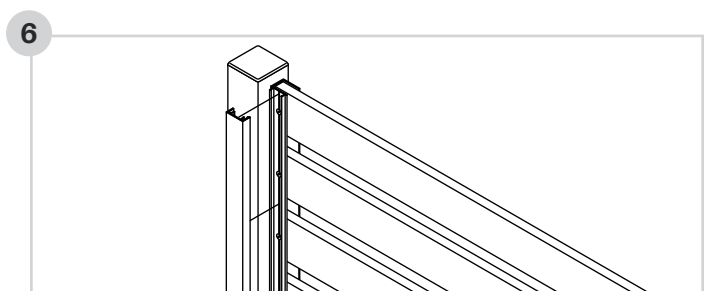

6 Cut snap on fixing cover to appropriate height

Attach snap on fixing cover to hide screws

Tip: If screen is wider than 1800mm, it is recommended to attach the centre support rail vertically at the centre of the screen. Cut centre support rail to appropriate height of screen and screw off to each slat at back side of screen

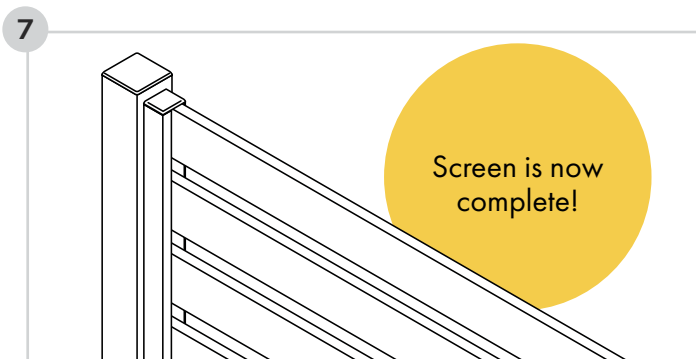

Snap on fixing cover install tip

Engage shorter leg of snap-on cover first.

At this point, the snap-on cover will be sitting off the side frame on an angle.

The longer leg must be at open side of side frame.

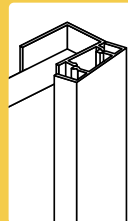

Starting from the top and working your way down, use a wood block and a hammer/mallet to tap the longer leg into place.

A short, sharp tap may be required to engage the long leg.

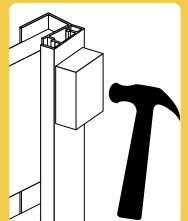

HORIZONTAL SLAT INSTALL GUIDE

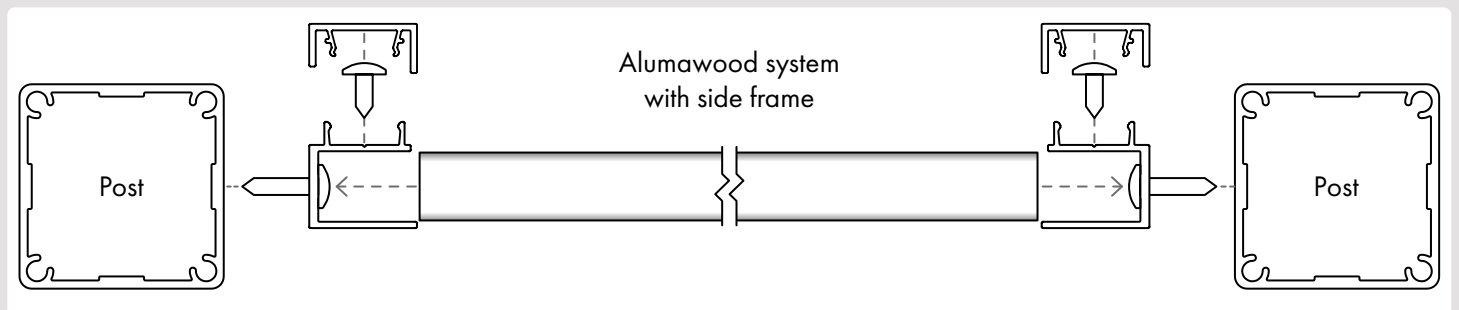
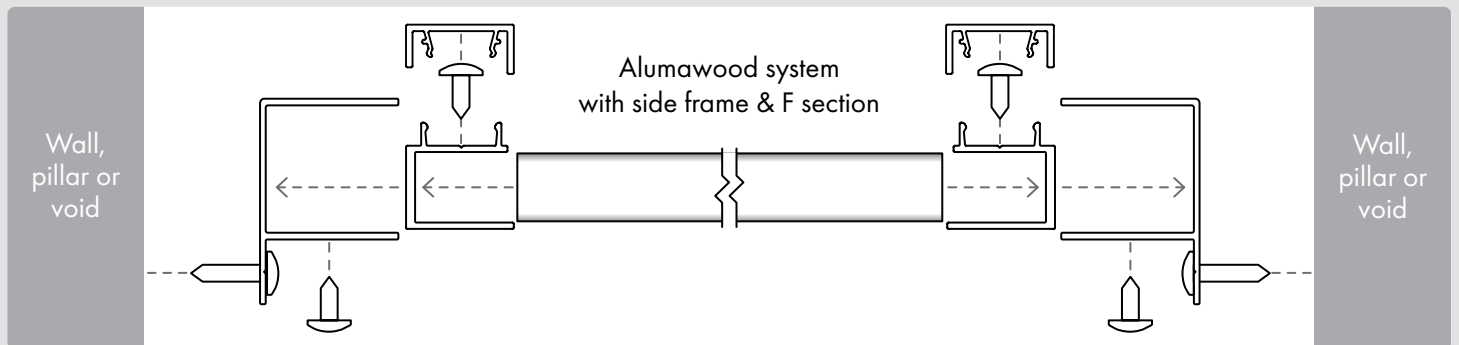
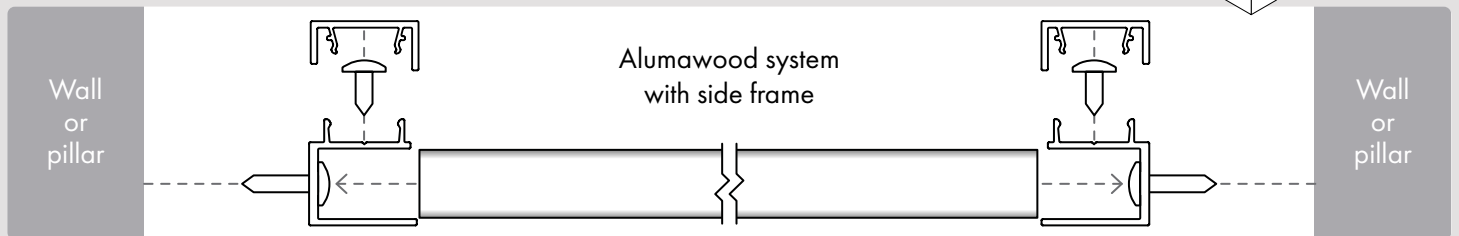
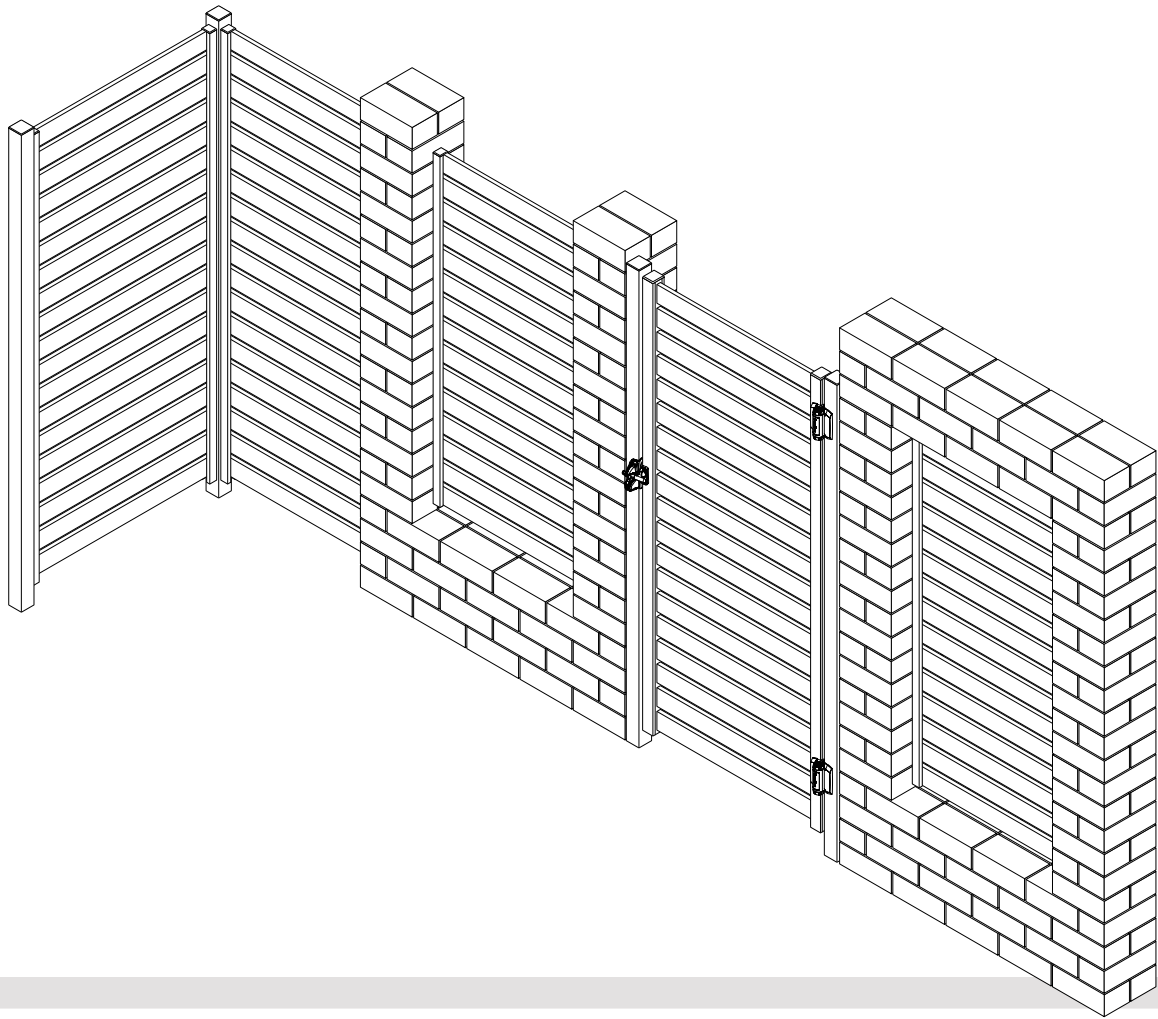



65mm slat spacing table

QUICKSCREEN

HORIZONTAL SLAT SYSTEM

Slat Qty

Total number of slats required for height shown in corresponding rows

Slat spacing

Height of gap between each slat

Height

The Alumawood side frames allow for variable gap spacing as each slat is fixed off at desired position. Any gap is achievable. Shown are specifications for the popular spacings of nil, 5mm, 9mm & 20mm spacing.

The formula to calculate variable gap screen height is:

$((65\text{mm (slat height)} + \text{desired gap}) \times \text{number of slats}) - \text{desired gap} + 3\text{mm}$ (for top cap).

For example, a 30mm desired gap with 14 slats: $(65 + 30) \times 14 - 30 + 3 = 1303\text{mm}$ high

Slat Qty	Slat spacing	Height
5	Nil	328mm
	5mm	348mm
	9mm	364mm
	20mm	408mm
6	Nil	393mm
	5mm	418mm
	9mm	438mm
	20mm	493mm
7	Nil	458mm
	5mm	488mm
	9mm	512mm
	20mm	578mm
8	Nil	523mm
	5mm	558mm
	9mm	586mm
	20mm	663mm
9	Nil	588mm
	5mm	628mm
	9mm	660mm
	20mm	748mm
10	Nil	653mm
	5mm	698mm
	9mm	734mm
	20mm	833mm
11	Nil	718mm
	5mm	768mm
	9mm	808mm
	20mm	918mm
12	Nil	783mm
	5mm	838mm
	9mm	882mm
	20mm	1003mm
13	Nil	848mm
	5mm	908mm
	9mm	956mm
	20mm	1088mm
14	Nil	913mm
	5mm	978mm
	9mm	1030mm
	20mm	1173mm
15	Nil	978mm
	5mm	1048mm
	9mm	1104mm
	20mm	1258mm
16	Nil	1043mm
	5mm	1118mm
	9mm	1178mm
	20mm	1343mm
17	Nil	1108mm
	5mm	1188mm
	9mm	1252mm
	20mm	1428mm
18	Nil	1173mm
	5mm	1258mm
	9mm	1326mm
	20mm	1513mm
19	Nil	1238mm
	5mm	1328mm
	9mm	1400mm
	20mm	1598mm
20	Nil	1303mm
	5mm	1398mm
	9mm	1474mm
	20mm	1683mm
21	Nil	1368mm
	5mm	1468mm
	9mm	1548mm
	20mm	1768mm
22	Nil	1433mm
	5mm	1538mm
	9mm	1622mm
	20mm	1853mm

Slat Qty	Slat spacing	Height
23	Nil	1498mm
	5mm	1608mm
	9mm	1696mm
	20mm	1938mm
24	Nil	1563mm
	5mm	1678mm
	9mm	1770mm
	20mm	2023mm
25	Nil	1628mm
	5mm	1748mm
	9mm	1844mm
	20mm	2108mm
26	Nil	1693mm
	5mm	1818mm
	9mm	1918mm
	20mm	2193mm
27	Nil	1758mm
	5mm	1888mm
	9mm	1992mm
	20mm	2278mm
28	Nil	1823mm
	5mm	1958mm
	9mm	2066mm
	20mm	2363mm
29	Nil	1888mm
	5mm	2028mm
	9mm	2140mm
	20mm	2448mm
30	Nil	1953mm
	5mm	2098mm
	9mm	2214mm
	20mm	2533mm
31	Nil	2018mm
	5mm	2168mm
	9mm	2288mm
	20mm	2618mm
32	Nil	2083mm
	5mm	2238mm
	9mm	2362mm
	20mm	2703mm
33	Nil	2148mm
	5mm	2308mm
	9mm	2436mm
	20mm	2788mm
34	Nil	2213mm
	5mm	2378mm
	9mm	2510mm
	20mm	2873mm
35	Nil	2278mm
	5mm	2448mm
	9mm	2584mm
	20mm	2958mm
36	Nil	2343mm
	5mm	2518mm
	9mm	2658mm
	20mm	3043mm
37	Nil	2408mm
	5mm	2588mm
	9mm	2732mm
	20mm	3128mm
38	Nil	2473mm
	5mm	2658mm
	9mm	2806mm
	20mm	3213mm
39	Nil	2538mm
	5mm	2728mm
	9mm	2880mm
	20mm	3298mm
40	Nil	2603mm
	5mm	2798mm
	9mm	2954mm
	20mm	3383mm



90mm slat spacing table

QUICKSCREEN HORIZONTAL SLAT SYSTEM

Slat Qty

Total number of slats required for height shown in corresponding rows

Slat spacing

Height of gap between each slat

Height

The Alumawood side frames allow for variable gap spacing as each slat is fixed off at desired position. Any gap is achievable. Shown are specifications for the popular spacings of nil, 5mm, 9mm & 20mm spacing.

The formula to calculate variable gap screen height is:
 $((90\text{mm (slat height)} + \text{desired gap}) \times \text{number of slats}) - \text{desired gap} + 3\text{mm}$
 (for top cap).

For example, a 30mm desired gap with 14 slats: $(90 + 30) \times 14 - 30 + 3 = 1653\text{mm}$ high

Slat Qty	Slat spacing	Height	Slat Qty	Slat spacing	Height
5	Nil	453	23	Nil	2073
	5mm	473		5mm	2183
	9mm	489		9mm	2271
	20mm	533		20mm	2513
6	Nil	543	24	Nil	2163
	5mm	568		5mm	2278
	9mm	588		9mm	2370
	20mm	643		20mm	2623
7	Nil	633	25	Nil	2253
	5mm	663		5mm	2373
	9mm	687		9mm	2469
	20mm	753		20mm	2733
8	Nil	723	26	Nil	2343
	5mm	758		5mm	2468
	9mm	786		9mm	2568
	20mm	863		20mm	2843
9	Nil	813	27	Nil	2433
	5mm	853		5mm	2563
	9mm	885		9mm	2667
	20mm	973		20mm	2953
10	Nil	903	28	Nil	2523
	5mm	948		5mm	2658
	9mm	984		9mm	2766
	20mm	1083		20mm	3063
11	Nil	993	29	Nil	2613
	5mm	1043		5mm	2753
	9mm	1083		9mm	2865
	20mm	1193		20mm	3173
12	Nil	1083	30	Nil	2703
	5mm	1138		5mm	2848
	9mm	1182		9mm	2964
	20mm	1303		20mm	3283
13	Nil	1173	31	Nil	2793
	5mm	1233		5mm	2943
	9mm	1281		9mm	3063
	20mm	1413		20mm	3393
14	Nil	1263	32	Nil	2883
	5mm	1328		5mm	3038
	9mm	1380		9mm	3162
	20mm	1523		20mm	3503
15	Nil	1353	33	Nil	2973
	5mm	1423		5mm	3133
	9mm	1479		9mm	3261
	20mm	1633		20mm	3613
16	Nil	1443	34	Nil	3063
	5mm	1518		5mm	3228
	9mm	1578		9mm	3360
	20mm	1743		20mm	3723
17	Nil	1533	35	Nil	3153
	5mm	1613		5mm	3323
	9mm	1677		9mm	3459
	20mm	1853		20mm	3833
18	Nil	1623	36	Nil	3243
	5mm	1708		5mm	3418
	9mm	1776		9mm	3558
	20mm	1963		20mm	3943
19	Nil	1713	37	Nil	3333
	5mm	1803		5mm	3513
	9mm	1875		9mm	3657
	20mm	2073		20mm	4053
20	Nil	1803	38	Nil	3423
	5mm	1898		5mm	3608
	9mm	1974		9mm	3756
	20mm	2183		20mm	4163
21	Nil	1893	39	Nil	3513
	5mm	1993		5mm	3703
	9mm	2073		9mm	3855
	20mm	2293		20mm	4273
22	Nil	1983	40	Nil	3603
	5mm	2088		5mm	3798
	9mm	2172		9mm	3954
	20mm	2403		20mm	4383

VERTICAL SLAT SYSTEM

The Alumawood System allows 65x16.5mm or 90x16.5mm slats to be installed using a cost effective top/bottom rail system. Each slat requires screwing off at top and bottom. Screws are hidden by a heavy duty "U" section at top and bottom. An "F" section is installed vertically on both sides which allows easy installation between posts or pillars. A complete system is available – panels, pedestrian gates and sliding gates.

Ideal for installations between pillars and existing posts!

ASSEMBLE ON-SITE OR IN YOUR WORKSHOP –

Panels fit into F section on both sides for easy installation. Problems with out of square pillars or posts can be easily overcome with F section fitting.

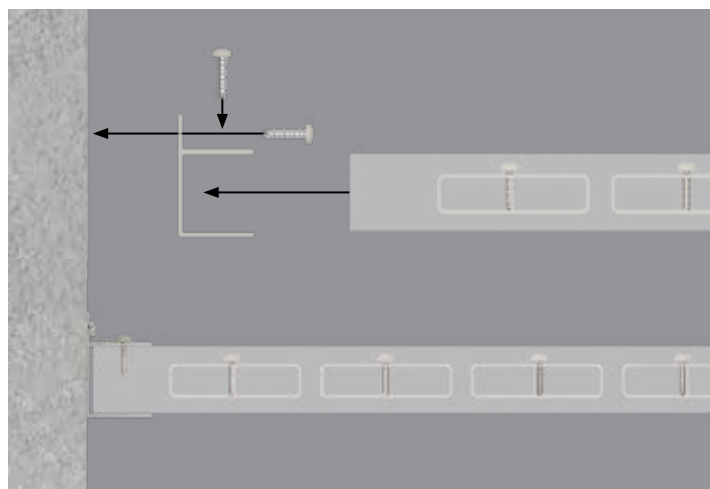

For
Island Grey

- 1 **F section**
AWQS-5800-F
Refer page 107



- 2 **U channel top/bottom channel**
AWQS-5000-HORIZ
Refer page 108



- 3 **Top/bottom frame**
AWQS-5800-SF
Refer page 107



- 4 **65x16.5mm or 90x16mm slat**
65mm: AW-5800-S65
90mm: AWQS-5800-S90-WRC*
*WRC finish only
Refer page 103

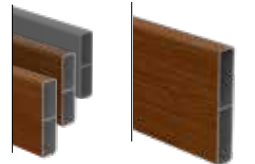

POSTS & ACCESSORIES –

- 1 50x50mm post
- 2 65x65mm heavy duty post
- 3 Top caps
- 4 Dress rings
- 5 Domical covers
- 6 Base plates

For full range of posts & accessories, see pages 111 & 112
** Monument powder coat finish to complement Island Grey



VERTICAL SLAT INSTALL GUIDE

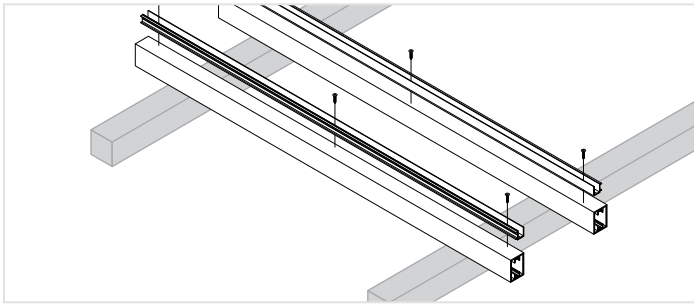

- 1 Place first slat on padded bearers, then place the top and bottom frames onto the slat.

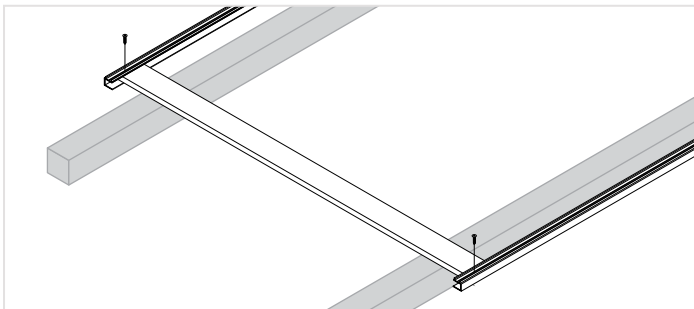

- 2 Position front edge of slat required distance from the edge of the top and bottom frame and screw through frame to affix at both end of the slat with 1x screw per end.

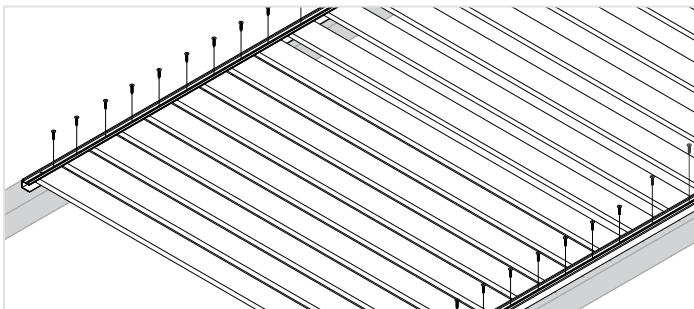

- 3 Slide remaining slats into the top and bottom frame and attach with single screw through top and bottom frames to affix, then check measure diagonals. Double screw fix first and last slats. **Keep slat spacing in mind!**

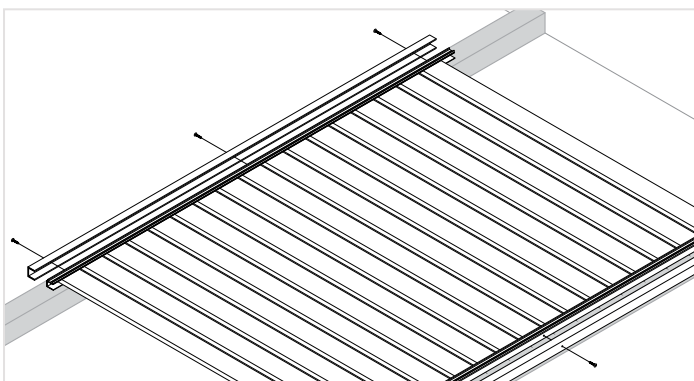

- 4 Place U channel over top and bottom frame, pre-drill 3mm holes and screw off in three points on top and bottom of the U channel – Measure in 50mm from the left and right edges, then one in the centre. **Ensure sufficient pilot holes are drilled before affixing, making sure they won't hit other screws.**



For panels over 1800mm wide, we suggest using a height adjustable foot underneath screen to prevent sagging of panel. Pre-drill 3mm holes and affix with screws. If using the height adjustable foot there is no need for a screw in the middle of the bottom rail.

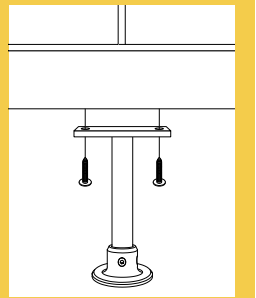

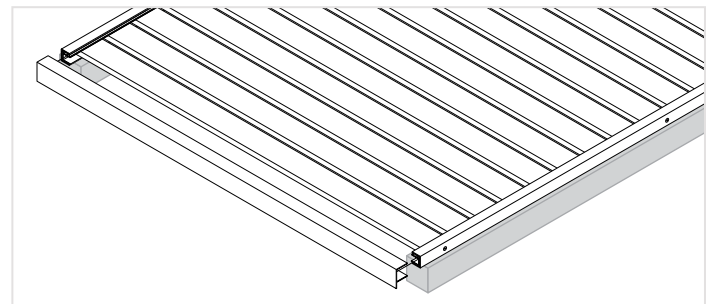

- 5 Place F section over each side of panel – F section will stay in place without screws until the last step.

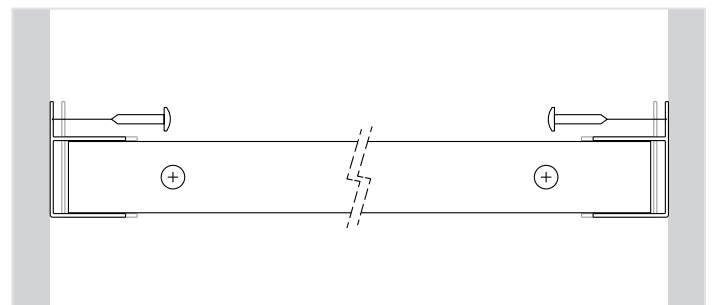

- 6 Lift panel into opening and push F section out to sit flush to wall then affix F section to wall (fixings not included). **Ensure sufficient pilot holes are drilled before affixing.**

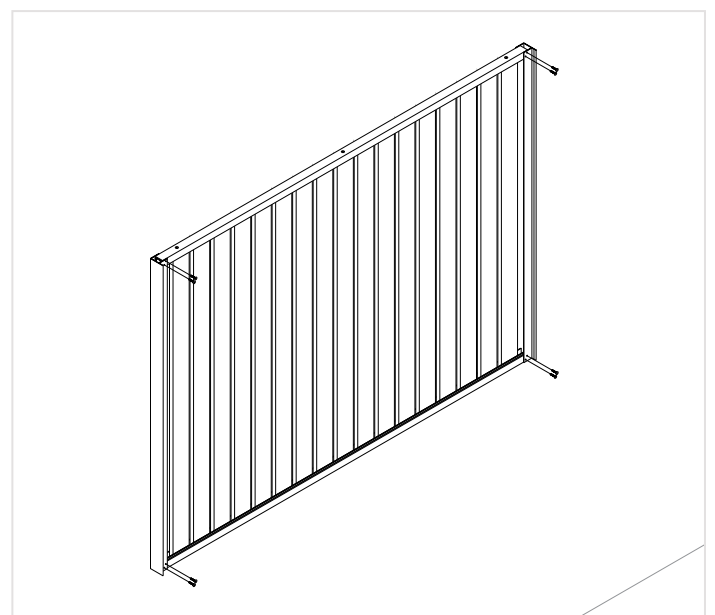

- 6 Affix panel to F section by pre-drilling 3mm holes and screwing through F section in corner positions – we suggest using 2 screws in each corner

innovative, non-weld Pedestrian gates

AVAILABLE IN 2 CONVENIENT SUPPLY OPTIONS

1

Long length supply

Buy long length extrusions then cut to size and assemble on-site or at your premises

2

Cut to size service

Simply provide gate size required – we will cut to size and flat pack for easy assembly

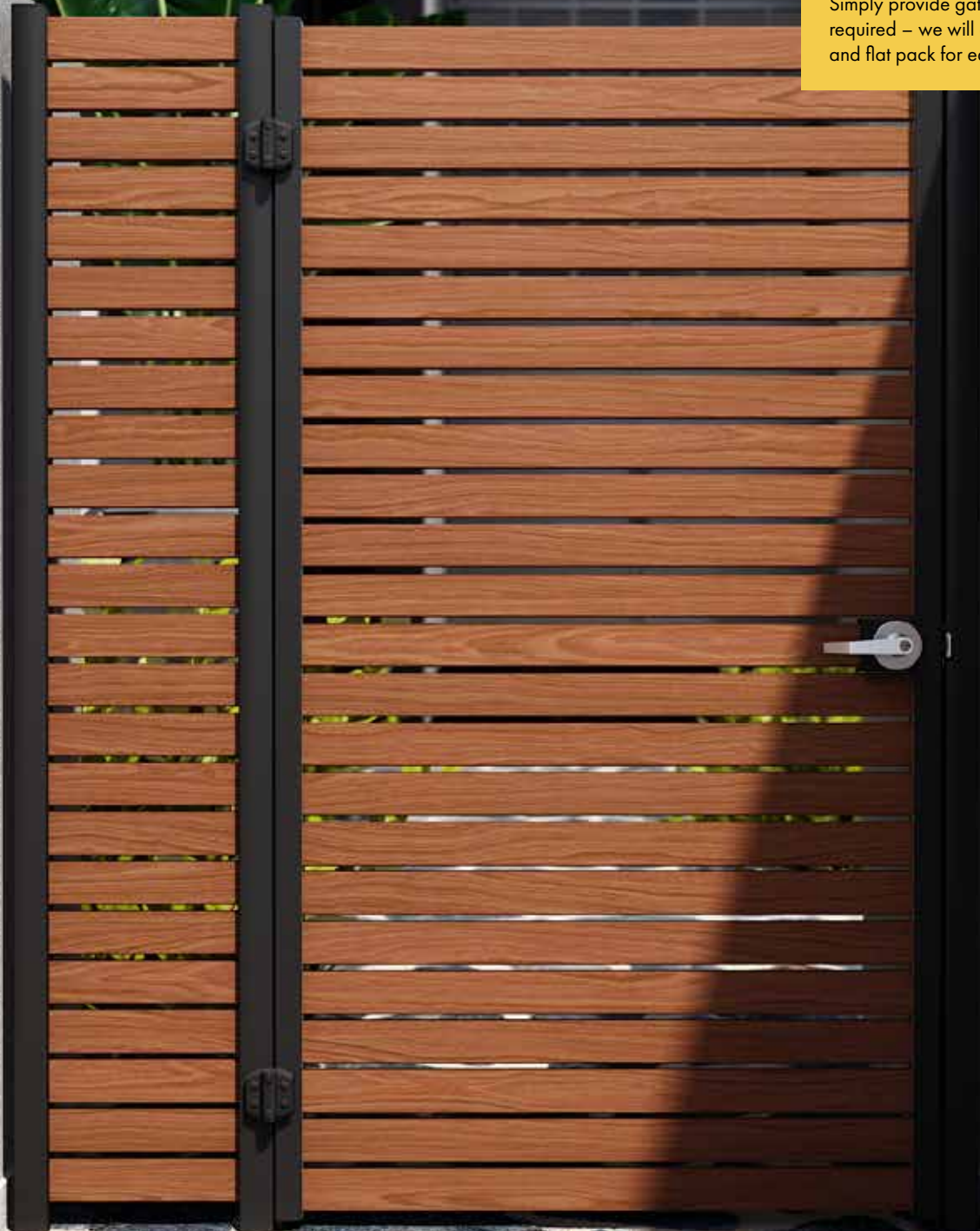

Pedestrian gate options

SELECT FROM A RANGE OF PEDESTRIAN GATE OPTIONS

We can cut to size, flat pack and send Australia wide or you can purchase long length extrusions and cut to size yourself.

Assemble pre-powder coated gates with no welding or riveting required.

Contact us for detailed assembly instructions



1 Horizontal slat pedestrian gate

Fitted with D&D Lokk Latch Deluxe

65mm x 16.5mm slats with 9mm or 20mm slat spacing

Patented gate side frames for fast assembly

Slats and side frames in Kwila or WRC imaged

Island Grey slats with monument powder coat frames



2 Horizontal slat pedestrian gate

Fitted with D&D Lokk Latch Deluxe

65mm x 16.5mm or 90mm x 16.5mm slats

Variable slat spacing

Each slat required to be screw fixed

Slats and side frames in Kwila or WRC imaged

Island Grey slats with monument powder coat frames

*WRC finish only for 90x16.5mm slat



3 Horizontal slat pedestrian gate

Fitted with Lockwood 001 deadlatch

65mm x 16.5mm slats with 9mm or 20mm slat spacing

Patented gate side frames for fast assembly

Slats Kwila or Island Grey, WRC imaged. Frames & lockbox available in black, monument or woodland grey powdercoat

Patented non-weld lockbox*

*Lockbox powder coated Terrain



4 Horizontal slat pedestrian gate

Fitted with knob or lever handle

65mm x 16.5mm slats with 9mm or 20mm slat spacing

Patented gate side frames for fast assembly

Patented non-weld lockbox

Slats Kwila or Island Grey, WRC imaged. Frames & lockbox available in black, monument or woodland grey powdercoat



5 Vertical slat pedestrian gate

Fitted with D&D Lokk Latch Deluxe

65mm x 16.5mm or 90mm x 16.5mm slats

Variable slat spacing

Each slat required to be screw fixed

Slats and side frames in Kwila or WRC* imaged

Slats Kwila or Island Grey, WRC imaged. Frames & lockbox available in black, monument or woodland grey powdercoat

PEDESTRIAN GATE OPTIONS

Option 1

Slats & frames imaged aluminium

Horizontal slot gate with 65mm x 16.5mm slats
9mm or 20mm slat spacing
Fitted with the D&D Lokk Latch Deluxe

SEE PAGES 129-134 FOR FULL
SPECIFICATIONS ON ALL
PRODUCTS LISTED BELOW

- 1 **Patented non-weld gate side frames**
Machined drill holes & slots – 9mm or 20mm spacing
Suits 65x16.5mm slat
AWXP-4200-GSF09 or AWXP-4200-GSF20
- 2 **Gate insert**
Snaps into gate side frame to hide gate slat fixing screws
AWXP-4200-GI
- 3 **Gate frame cap**
Simply press into top of gate frames
XP-GFC
- 4 **Gate frame screws**
12 gauge x 65mm long with flange hex head
XP-SCREWSGF-10PK
- 5 **Gate hinges**
A range of hinging options available
See pages 72-76 for hinge options
- 6 **65mm x 16.5mm gate slat w/ 2x screw flutes**
Screw fluted slats at top/middle/bottom of gate
AW-5800-GB65
- 7 **65x16.5mm slat**
Standard slats held in place with patented friction fitting gate side frame
AW-5800-S65
- 8 **Lokk Latch Deluxe**
Manufactured by D&D Technologies
Lockable both sides
LL-DL | See pages 77 & 78



! INFORMATION BELOW RELATES TO OPTION 1 ONLY

GATE CONFIGURATIONS 'Gate slat' positioning in conjunction with width & height specifications

Up to 1000mm wide



Gate blades:

- 2x top
- 1x middle
- 1x bottom

From 1001mm to 1200mm wide



Gate blades:

- 2x top
- 1x middle
- 2x bottom

PEDESTRIAN GATE OPTIONS

Option 2

Slats & frames imaged aluminium

Horizontal slat gate with 65mm or 90mm x 16.5mm slats
Variable slat spacing including nil spacing
Fitted with the D&D Lokk Latch Deluxe
Maximum 1200mm wide

SEE PAGES 129-134 FOR FULL SPECIFICATIONS ON ALL PRODUCTS LISTED BELOW

1 Patented non-weld gate side frames

Machined drill holes
AWXP-4200-GSF20

2 Gate insert

Snaps into gate side frame to hide required fixing screws
AWXP-4200-GI

3 Gate frame cap

Simply press into top of gate frames
XP-GFC

4 Gate frame screws

12 gauge x 65mm long with flange hex head
Use to fix off heavy duty top/bottom rail
XP-SCREWSGF-10PK

5 Gate hinges

A range of hinging options available
See pages 72-76 for hinge options

6 Non-punched gate infill

Replaces slotted infill from gate side frame
XP-XBAT-4200-INF

7 Quickscreen sideframe

Affix to inner face of gate side frame
Insert and screw off each slat – variable spacing
AWQS-5800-SF

8 Quickscreen concealed fixing cover

Snap-on cover to hide slat fixing screws
AWQS-5800-CFC

9 Fixing screws

Use to affix Quickscreen side frames and slats
All slats must be screw fixed to side frames
XP-SCREWS

10 65x16.5mm or 90x16mm slat

Slats held in place with fixing screws
AW-5800-S65 / AWQS-5800-S90 *

* 90x16.5mm slat in WRC only

11 65x45mm heavy duty rail

Position at top & bottom of gate
XP-6100-HD6545

12 Lokk Latch Deluxe w/ packer

Manufactured by D&D Technologies
Lockable both sides
LL-DL | See pages 77 & 78



! INFORMATION BELOW RELATES TO OPTION 1 ONLY

From 1201 mm to 1500mm wide

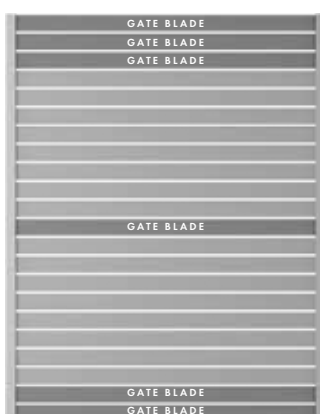

Gate blades:

- 3x top
- 1x middle
- 2x bottom

From 1501 mm to 2100mm wide

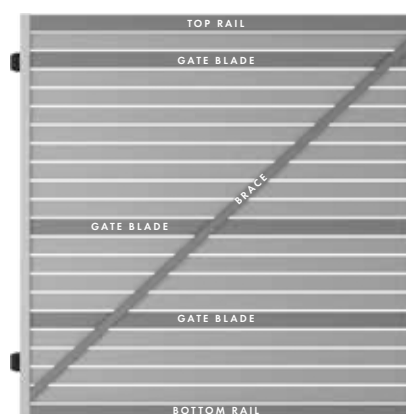

Gate blades:

- 1x 2nd slat down
- 1x middle
- 1x ¾ down

Top & bottom rail:

- 1x HD top rail
- 1x HD bottom rail

Brace:

- 1x centre support rail (Diagonal)

PEDESTRIAN GATE OPTIONS

Option 3

Slats & side frames imaged aluminium
Lockbox powder coated Terrain

Horizontal slat gate with 65mm x 16.5mm slats
9mm or 20mm slat spacing
Fitted with the Lockwood 001 deadlatch
*Inwards swinging only

SEE PAGES 129-134 FOR FULL
SPECIFICATIONS ON ALL
PRODUCTS LISTED BELOW

- 1 Patented non-weld gate side frames**
Machined drill holes & slots – 9mm or 20mm spacing
Suits 65x16.5mm slat
AWXP-4200-GSF09 or AWXP-4200-GSF20
- 2 Gate insert**
Snaps into gate side frame to hide gate slat fixing screws
AWXP-4200-GI
- 3 Gate stop & rubber**
Required for latch side of gate
XP-4200-GSTOP / XP-GATESTOP-RUB
- 4 Aluminium CSK blind rivet**
CSK rivets recommended due to 3mm gap
between latching post & gate side frame
XP-GATESTOP-RIV-10PK
- 5 Gate frame cap**
Simply press into top of gate frames
XP-GFC
- 6 Gate frame screws**
12 gauge x 65mm long with flange hex head
XP-SCREWSGF-10PK
- 7 Gate hinges**
A range of hinging options available
See pages 72-76 for hinge options
- 8 65mm x 16.5mm gate slat w/ 2x screw flutes**
Screw fluted slats at top/middle/bottom of gate
AWXP-5800-GB65
- 9 65x16.5mm slat**
Standard slats held in place with patented
friction fitting gate side frame
AW-5800-S65

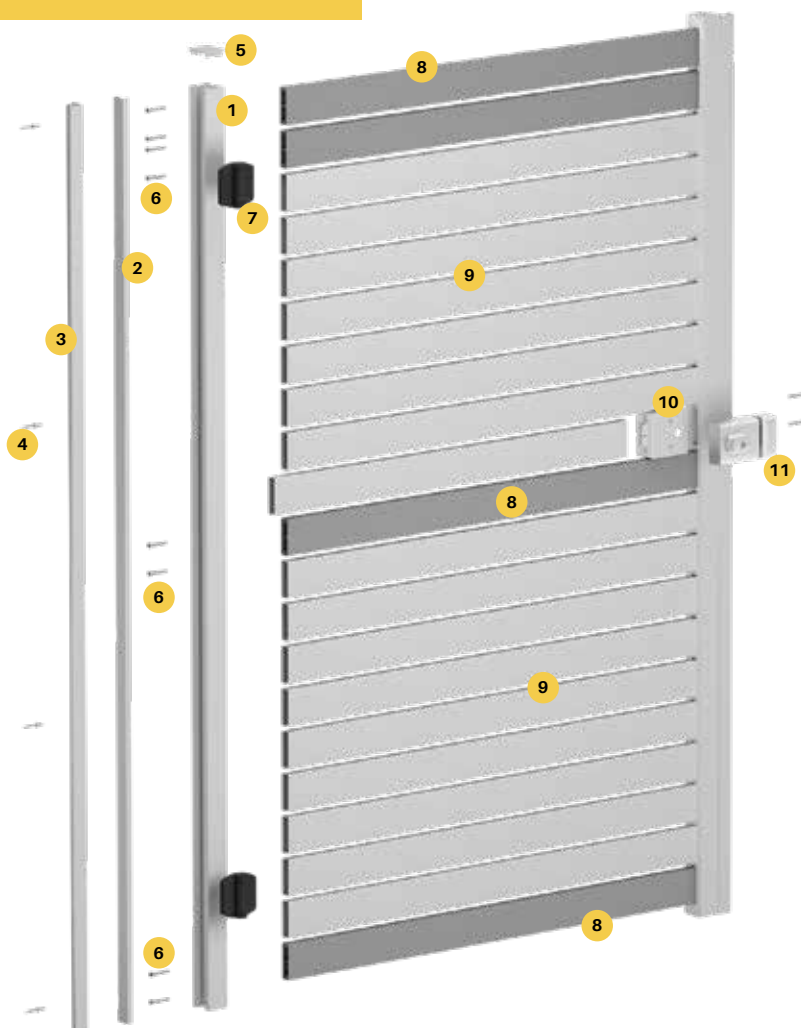

- 10 Deadlatch lockbox**
Patented non-weld lockbox to suit
Lockwood 001 deadlatch
XP-LBOX-DL *Powder coated Terrain finish

- 11 Lockwood 001 deadlatch**
Manufactured by Lockwood
XP-DL001 | See page 133

! INFORMATION BELOW RELATES TO OPTIONS 3 & 4

GATE CONFIGURATIONS 'Gate slat' positioning in conjunction with width & height specifications

Up to 1000mm wide



Gate blades:

- 2x top
- 1x middle
- 1x bottom

From 1001mm to 1200mm wide



Gate blades:

- 2x top
- 1x middle
- 2x bottom

PEDESTRIAN GATE OPTIONS

Option 4

Horizontal slot gate with 65mm x 16.5mm slats
9mm or 20mm slot spacing
Fitted with knob or lever handle set

SEE PAGES 129-134 FOR FULL SPECIFICATIONS ON ALL PRODUCTS LISTED BELOW

Slats timber imaged

Side frames & lockbox powder coated Black, Monument or Woodland Grey

1 Gate lever set lock box kit

Inclusions:

- 1a 2x 2094mm gate side frame (9mm or 20mm spacing)
 - 1b 2x Gate insert
 - 1c 2x Machined gate stop (Left & right) with bulb rubber
 - 1d 1x Non-machined gate stop (for hinge side)
 - 1e 2x Gate frame caps
 - 1f 1x 10 pack Wafer head 10-16x16mm screws (For affixing gate stop)
- XP-GKIT-LSET09 or XP-GKIT-LSET20

2 Gate frame screws

12 gauge x 65mm long with flange hex head
XP-SCREWSGF-10PK

3 Gate hinges

A range of hinging options available
See pages 72-76 for hinging options

4 65mm x 16.5mm gate slat w/ 2x screw flutes

Screw fluted slats at top/middle/bottom of gate
XP-6100-GB65

5 65x16.5mm slat

Standard slats held in place with patented friction fitting gate side frame
AW-5800-S65

6 Lockbox

Patented non-weld lockbox to suit knob/lever handle set
XP-LBOX-LSET

7 Knob or lever handle set

Key lockable both sides
XP-HDL-KNOB / XP-HDL-LEVER / XP-HDL-LW534
See page 133



! INFORMATION BELOW RELATES TO OPTIONS 3 & 4

From 1201mm to 1500mm wide



Gate blades:

- 3x top
- 1x middle
- 2x bottom

From 1501mm to 2100mm wide

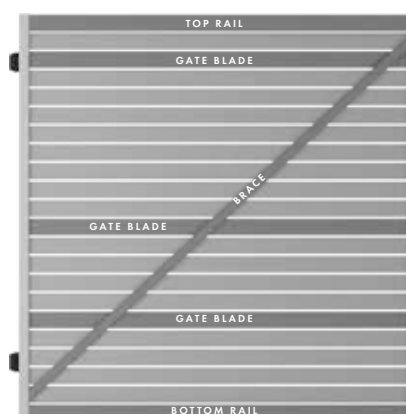

Gate blades:

- 1x 2nd slat down
- 1x middle
- 1x ¾ down

Top & bottom rail:

- 1x HD top rail
- 1x HD bottom rail

Brace:

- 1x centre support rail (Diagonal)

PEDESTRIAN GATE OPTIONS

Option 5

Slats & frames imaged aluminium

Vertical slat gate with 65mm or 90mm x 16.5mm slats
 Variable slat spacing including nil spacing
 Fitted with the D&D Lokk Latch Deluxe
 Maximum 1200mm wide

SEE PAGES 129-134 FOR FULL
 SPECIFICATIONS ON ALL
 PRODUCTS LISTED BELOW

- 1 **Patented non-weld gate side frames**
Machined drill holes
AWXP-4200-GSF20
- 2 **Gate insert**
Snaps into gate side frame to hide top & bottom rail fixing screws
AWXP-4200-GI
- 3 **Gate frame cap**
Simply press into top of gate frames
XP-GFC
- 4 **Gate frame screws**
12 gauge x 65mm long with flange hex head
Use to fix off heavy duty top/bottom rail
XP-SCREWSGF-10PK
- 5 **Gate hinges**
A range of hinging options available
See pages 72-76 for hinging options
- 6 **Non-punched gate infill**
Replaces slotted infill from gate side frame
XP-XBAT-4200-INF
- 7 **U channel**
Affix to vertical inner face of gate side frames
Reduces potential light gap on both vertical edges of gate
AWQS-5000-HORIZ
- 8 **Quickscreen sideframe**
Affix to inner face of top & bottom rails
Insert and screw off each slat – variable spacing
AWQS-5800-SF
- 9 **Quickscreen concealed fixing cover**
Snap-on cover to hide slat fixing screws
AWQS-5800-CFC
- 10 **Fixing screws**
Use to affix Quickscreen side frames and slats
All slats must be screw fixed to side frames
XP-SCREWS
- 11 **65x45mm heavy duty rail**
Position at top & bottom of gate
AWXP-5800-HD6545
- 12 **65x16.5mm or 90x16mm slat**
Slats held in place with fixing screws
AW-5800-S65 / AWQS-5800-S90 *90x16.5mm slat in WRC only
- 13 **Lokk Latch Deluxe w/ packer**
Manufactured by D&D Technologies
Lockable both sides
LL-DL | See page 77 & 78



When calculating even spacing between vertical slats, overall gate width should be carefully considered to ensure first and last gap (between gate side frames and first/last slat) are kept uniform with other slat spacing

GATE EXTRUSIONS

Slat Options

Refer page 105

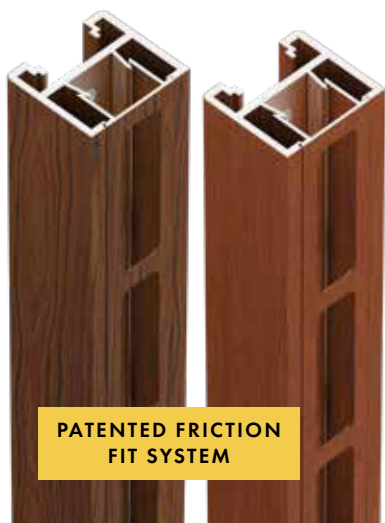

9MM SPACING Slotted gate side frame

4200MM LONG

Order Code: **AWXP-4200-GSF09**
XP-4200-GSF09-MN

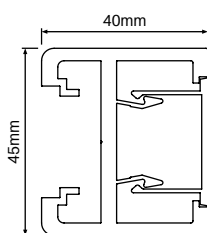

TECH SPECS

- PP 170
- Alloy 6063-T5 / 4200mm long
- 3mm wall thickness with 3.8mm centre crossmember
- Slotted insert to suit 65x16.5mm slat with 9mm spacing
- Patented frame for friction insertion of slats
- Crossmember machined with drill holes along entire length to suit screw fixing of strategically placed 'gate slats' featuring screw flutes
- lxx = 6.294 x 10E3 mmE4
- lyy = 152.403 x 10E3 mmE4

Finishes



KWILA
(KWI)



WESTERN
RED CEDAR
(WRC)



MONUMENT
(MN)
For Island Grey

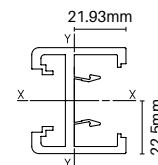

20MM SPACING Slotted gate side frame

4200MM LONG

Order Code: **AWXP-4200-GSF20**
XP-4200-GSF20-MN

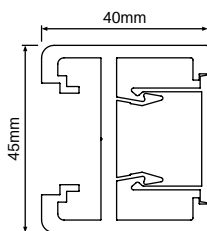

TECH SPECS

- PP 170
- Alloy 6063-T5 / 4200mm long
- 3mm wall thickness with 3.8mm centre crossmember
- Slotted insert to suit 65x16.5mm slat with 20mm spacing
- Patented frame for friction insertion of slats
- Crossmember machined with drill holes along entire length to suit screw fixing of strategically placed 'gate slats' featuring screw flutes
- lxx = 6.294 x 10E3 mmE4
- lyy = 152.403 x 10E3 mmE4

Finishes



KWILA
(KWI)



WESTERN
RED CEDAR
(WRC)



MONUMENT
(MN)
For Island Grey

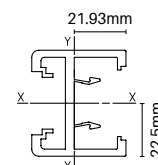

Snap-in gate insert

4200MM LONG

Order Code: **AWXP-4200-GI**
XP-4200-GI-MN

MATES WITH AWXP-4200-GSF09/20
XP-4200-GSF09/20

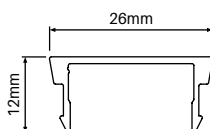

TECH SPECS

- PP 100 / AP 100
- Alloy 6060-T5 / 4200mm long
- Snap-in gate insert mates with gate side frame
- Hides screws required for fixing 'gate slats' into position
- lxx = 0.86 x 10E3 mmE4
- lyy = 5.93 x 10E3 mmE4

Finishes



KWILA
(KWI)



WESTERN
RED CEDAR
(WRC)



MONUMENT
(MN)
For Island Grey

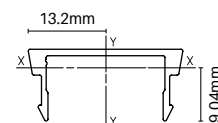

GATE EXTRUSIONS

NON-PUNCHED

Gate infill

4200MM LONG

Order Code: **XP-XBAT-4200-INF**

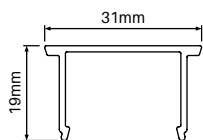

Finishes



KWILA
(KWI)



WESTERN
RED CEDAR
(WRC)



MONUMENT
(MN)
For Island Grey

TECH SPECS

- PP 100 / AP 133
- Alloy 6060-T5 / 4200mm long
- Non-punched snap-in infill for gate side frames
- Required when making vertical gates, variable spaced horizontal slat gates or gates using 90mm x 16.5mm slats
- Replace existing slotted infill in gate side frame with non-punched gate infill
- lxx = 2.94 x 10E3 mmE4
- lyy = 9.50 x 10E3 mmE4

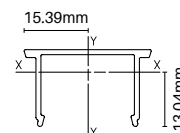

Side frame

5800MM LONG

Order Code: **AWQS-5800-SF**
QS-5800-SF-MN

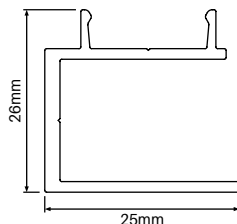

Finishes



KWILA
(KWI)



WESTERN
RED CEDAR
(WRC)



MONUMENT
(MN)
For Island Grey

TECH SPECS

- PP 104 / AP 156
- Alloy 6063-T6 / 5800mm long
- Each slat must be screw fixed to frame
- Required for vertical slat gates, variable spaced horizontal gates or gates using 90x16.5mm slat
- Screw fixings are hidden when panel is assembled
- lxx = 9.58 x 10E3 mmE4
- lyy = 8.38 x 10E3 mmE4

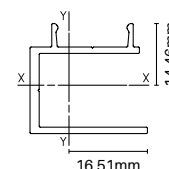

Concealed fixing cover

5800MM LONG

Order Code: **AWQS-5800-CFC**
QS-5800-CFC-MN

MATES WITH AWQS-5800-SF
QS-5800-CFC

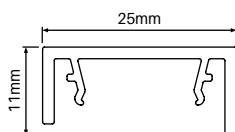

Finishes



KWILA
(KWI)



WESTERN
RED CEDAR
(WRC)



MONUMENT
(MN)
For Island Grey

TECH SPECS

- PP 100 / AP 116
- Alloy 6060-T5 / 5800mm long
- Snap-on cover for Alumawood side frame
- Hides screws used to affix slats to side frame
- lxx = 0.71 x 10E3 mmE4
- lyy = 6.58 x 10E3 mmE4

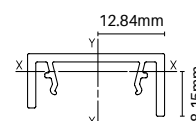

GATE EXTRUSIONS



Heavy duty top/bottom rail

5800MM OR 6100MM LONG

Order Code: **AWXP-5800-HD6545**
XP-6100-HD6545-MN

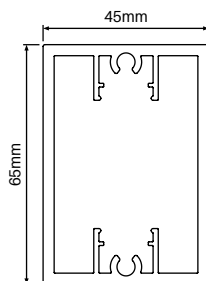

Finishes



KWILA
(KWI)



WESTERN
RED CEDAR
(WRC)



MONUMENT
(MN)
For Island Grey

TECH SPECS

- PP 219 / AP 219
- Alloy 6063-T5 / 5800mm long for WRC & Kwila finish
- Alloy 6063-T5 / 6100mm long for Monument finish
- 3mm wall thickness
- Heavy duty top/bottom rail used for wide gates
- Also required for vertical slat gates, horizontal gates with variable spacing or gates fitted with a lockbox
- Non weld assembly using 12 gauge screws into screw flutes (Code: XP-SCREWSGF-10PK)
- lxx = 206.98 x 10E3 mmE4
- lyy = 427.32 x 10E3 mmE4

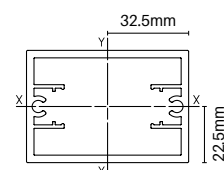

Gate stop

4200MM LONG

Order Code: **AWXP-4200-GSTOP**
XP-4200-GSTOP-MN

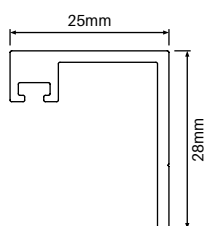

Finishes



KWILA
(KWI)



WESTERN
RED CEDAR
(WRC)



MONUMENT
(MN)
For Island Grey

TECH SPECS

- PP 106 / AP 123
- Alloy 6063-T5 / 4200mm long
- Must be used on gates fitted with Lockwood 001 lockbox
- Bulb rubber sold separately (Code: XP-GATESTOP-RUB)
- lxx = 7.61 x 10E3 mmE4
- lyy = 10.95 x 10E3 mmE4

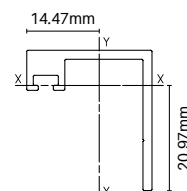

Heavy duty U channel

5000MM LONG

Order Code: **AWQS-5000-HORIZ**
QS-5000-HORIZ-MN

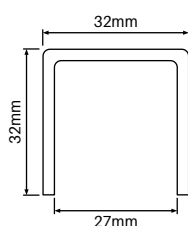

FOR VERTICAL SLAT

Finishes



KWILA
(KWI)



WESTERN
RED CEDAR
(WRC)



MONUMENT
(MN)
For Island Grey

TECH SPECS

- PP 184 / AP 184
- Alloy 6060-T5
- 5000mm long
- Required for vertical slat pedestrian gates only. Use on both internal vertical sides to reduce light gaps at gate edges
- 2.5mm wall thickness
- lxx = 23.97 x 10E3 mmE4
- lyy = 38.92 x 10E3 mmE4

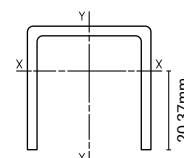

GATE KITS FOR LEVER/KNOB SETS

9mm gate lockbox kit

SUITABLE FOR LEVER/KNOB LOCK SET

Order Code: **XP-GKIT-LSET09**

- Gate side frame kit is specifically machined to suit horizontal pedestrian gate with lockbox and KNOB/LEVER set
- Patented non-weld assembly system: Use pre-powder coated aluminium lockbox (Code: XP-LBOX-LSET)
- Suits 65x16mm slats with **9mm spacing**
- Lockbox and lever/knob handle sold separately

Finish – powder coat



KIT INCLUSIONS

- a. 2 x 2094mm long Gate Side Frame slotted with 9mm space (1pc has extra machining for lock set)
- b. 2 x 2094mm long Gate Inserts
- c. 1 x 2200mm long Right hand machined Gate Stop
- d. 1 x 2200mm long Left hand machined Gate Stop
- e. 1 x 2200mm long non-machined Gate Stop (for hinge side)
- f. 2 x 2250mm long Gate Stop Rubber
- g. 2 x Gate Frame Cap - Black nylon
- h. 1 x 10 pack Wafer head 10-16 x 16mm screws (for affixing gate stop)

CONTEMPORARY LOOK
TIMBER IMAGE SLATS WITH POWDER COATED SIDE FRAME

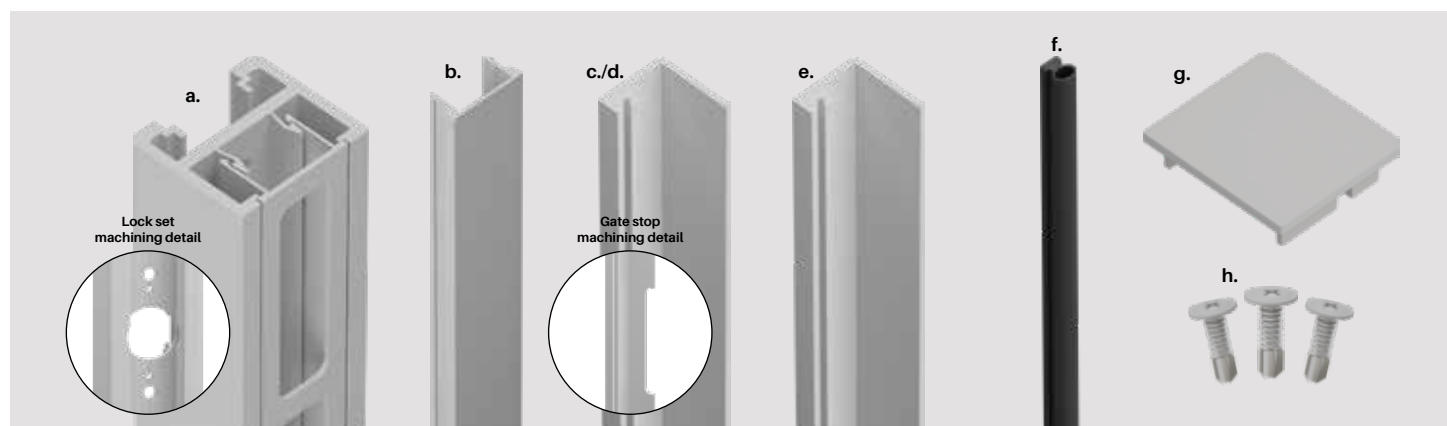

20mm gate lockbox kit

SUITABLE FOR LEVER/KNOB LOCK SET

Order Code: **XP-GKIT-LSET20**

- Gate side frame kit is specifically machined to suit horizontal pedestrian gate with lockbox and KNOB/LEVER set
- Patented non-weld assembly system: Use pre-powder coated aluminium lockbox (Code: XP-LBOX-LSET)
- Suits 65x16mm slats with **20mm spacing**
- Lockbox and lever/knob handle sold separately

Finish – powder coat



KIT INCLUSIONS

- a. 2 x 2094mm long Gate Side Frame slotted with 20mm space (1pc has extra machining for lock set)
- b. 2 x 2094mm long Gate Inserts
- c. 1 x 2200mm long Right hand machined Gate Stop
- d. 1 x 2200mm long Left hand machined Gate Stop
- e. 1 x 2200mm long non-machined Gate Stop (for hinge side)
- f. 2 x 2250mm long Gate Stop Rubber
- g. 2 x Gate Frame Cap - Black nylon
- h. 1 x 10 pack Wafer head 10-16 x 16mm screws (for affixing gate stop)

CONTEMPORARY LOOK
TIMBER IMAGE SLATS WITH POWDER COATED SIDE FRAME

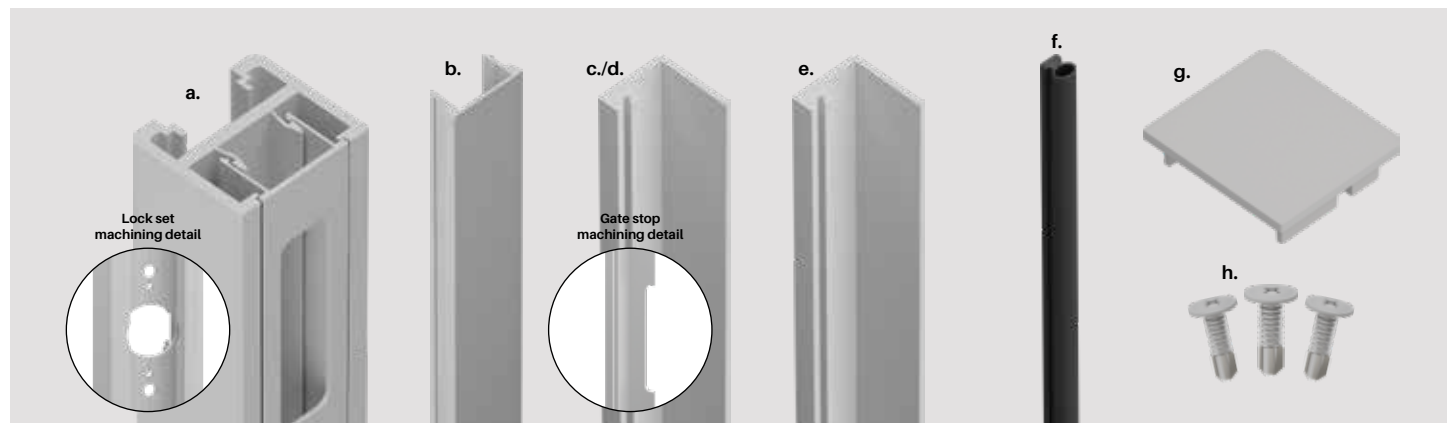

GATE ACCESSORIES



Deadlatch lockbox

ALUMINIUM

Terrain

Order Code: **AW-LBOX-DL-TR**

- Patented non-weld lockbox
- Terrain powdercoat matches well with Kwila & WRC
- Suits horizontal slat gates with 65x16.5mm slats
- Must use with gate side frame (AWXP-4200-GSF09/20)
- Screw fix assembly of pre-powder coated lockbox and extrusion
- Suits Lockwood 001 deadlatch (XP-DL001)



Lever/knob lockbox

ALUMINIUM

Black, Monument or Woodland Grey

Order Code: **XP-LBOX-LSET-B/MN/G**

- Patented non-weld lockbox
- Powder coated black, monument or woodland grey
- Suits horizontal slat gates with 65x16.5mm slats
- Must use with gate kits (XP-GKIT-LSET09/20)
- Screw fix assembly of pre-powder coated lockbox and extrusion
- Suits knob or lever sets (Stanley or Lockwood models)



Lockwood round knob set

HIGH PURITY ZINC ALLOY

Order Code: **XP-HDL-LW534**

- Lockwood model 534
- Knob set keyed both sides
- Lock / unlock both sides
- Suits left or right gate opening
- Satin Chrome brushed finish
- C4 5 pin on outside
- C4 6 pin restricted compatible on inside



Lockwood 001 deadlatch

12Gx65MM HEX

FLANGE HEAD

Order Code: **XP-DL001**

- Lockwood 001 deadlatch to suit metal frames
- Market leading performance & reliability
- Only suits inwards swinging gate
- Cut-resistant stainless steel bolt



Stanley round knob set

STAINLESS STEEL

Order Code: **XP-HDL-KNOB**

- Knob set keyed both sides
- Lock / unlock both sides
- Suits left or right gate opening
- Stainless steel knob and rose
- C4 6 pin restricted compatible (inside & outside)



Stanley lever set

STAINLESS STEEL

Order Code: **XP-HDL-LEVER**

- Lever set keyed both sides
- Lock / unlock both sides
- Suits left or right gate opening
- Stainless steel knob and rose
- C4 6 pin restricted compatible (inside & outside)

Electric Striker

Order Code: **XP-HDL-ES**

- Optional electric striker kit
- Left or right handing
- Power required to lock/unlock
- 12 volt (DC current)
- LATCHING POST - face mount SS304 striker face plate with built in side keeper
- Requirement to notch latching post to recess electric striker mechanism
- Allow 9mm latching gap
- Compatible with locks: XP-HDL-LW534
XP-HDL-KNOB



GATE ACCESSORIES



Gate frame cap

NYLON

Black / Monument

Order Code: **XP-GFC-B**

- UV stabilised nylon – 3mm thick cap
- Available in 5 colours
- Suits gate side frame
- Press-in flat cap



BLACK
(B)



MONUMENT
(MN)
For Island Grey



Self drilling wafer screws

10Gx16MM – BAG OF 100

Black, Monument

Order Code: **XP-SCREWS-B/MN**

- 10G x 16mm self drilling wafer head zinc plated
- Powder coated heads for neat finish
- Use to screw fix slats to Quickscreen side frame or to affix centre support rail to slats



Countersunk blind rivet

4.0x8.4

Order Code: **XP-GATESTOP-RIV-10PK**

- Countersunk aluminium rivet – 10 pack
- Use for affixing gate stop to post when using a lockbox with Lockwood 001 deadlatch – due to 3mm gap requirement between gate side frame and post rivets are required (as screw heads may interfere)



Nylon packer

USE WITH D&D

LOKK LATCH DELUXE

Order Code: **XP-PACKER**

- UV stabilised nylon
- Must be used when installing a D&D Lokk Latch Deluxe
- Packer aligns Lokk Latch Deluxe with gate side frame
- Affixes to inner face of gate side frame positioned under Lokk Latch striker



Gate stop rubber

4300MM LONG

Order Code: **XP-GATESTOP-RUB**

- Used as bumper for gate stop (mates with XP-4200-GSTOP)
- Rubber feeds into cavity in gate stop extrusion
- Cut to required length



PACK OF 10

Gate frame screws

12Gx65MM HEX FLANGE HEAD

Order Code: **XP-SCREWSGF-10PK**

- Use to secure gate slats to gate side frame through pre-machined holes in gate side frames
- Hex flange head for easy assembly

GATE ASSEMBLY: SIMPLE OVERVIEW

GATE OPTIONS 1, 3 & 4

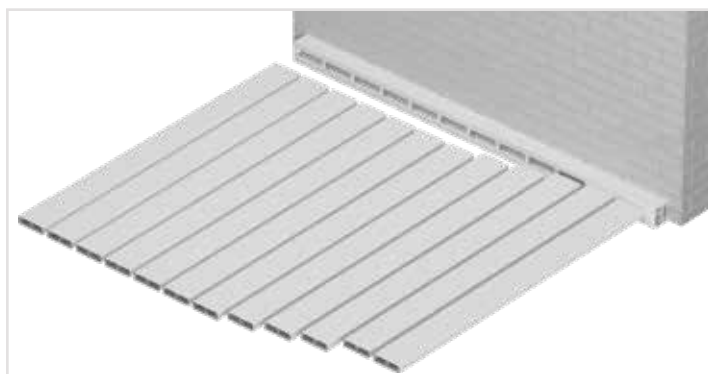

- 1 On a flat protected surface, lay 1x gate side frame with slotted spacer infill and rest against a padded stop and tap slats and gate blades into place

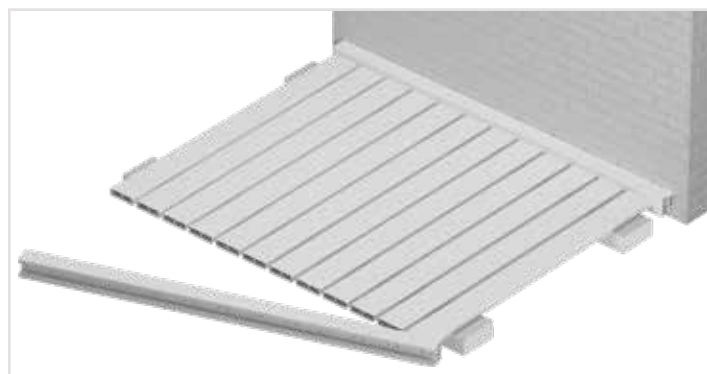

- 2 Elevate slats and gate side frame on two padded bearers. Engage second gate side frame to slats and top frame until all slats are fully engaged
TIP: Start at one end and work slats in from one end to the other



- 3 Screw off gate blades at required positions. Ensure gate is square by measuring diagonals



- 4 Slide 2x outer infills down into position to hide screw heads

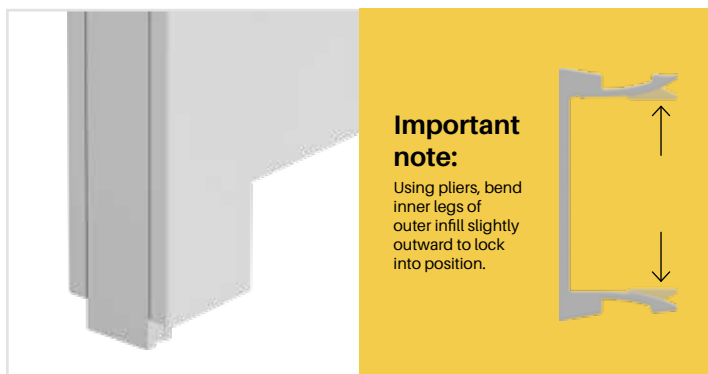

- 5 Slide 2x outer infills past end of gate side frame (approx. 10mm), then using pliers, bend inner legs of outer infill slightly outwards. Tap outer infill back to level with gate side frame
TIP: This step stops the outer infill from sliding down prior to hardware installation



- 6 Insert top caps into side frames

To determine the actual slat width for your gate, make a deduction of 36mm to the overall gate width (outer edge to outer edge of gate side frame)

FORMULA FOR SLAT WIDTH:
OVERALL GATE WIDTH – 36MM

You need to allow for hinge and latch gaps
Check hinge and latch hardware specifications for gaps required and take this information into account when determining overall gate width

Contact us for further installation instructions when using lockboxes etc.

GATE ASSEMBLY

GATES WIDER THAN 1500MM

- 1 When the gate is wider than 1500mm, 2x heavy duty top/bottom rails are used in place of the top and bottom gate blades (Additional gate blades are still required as per page 127).

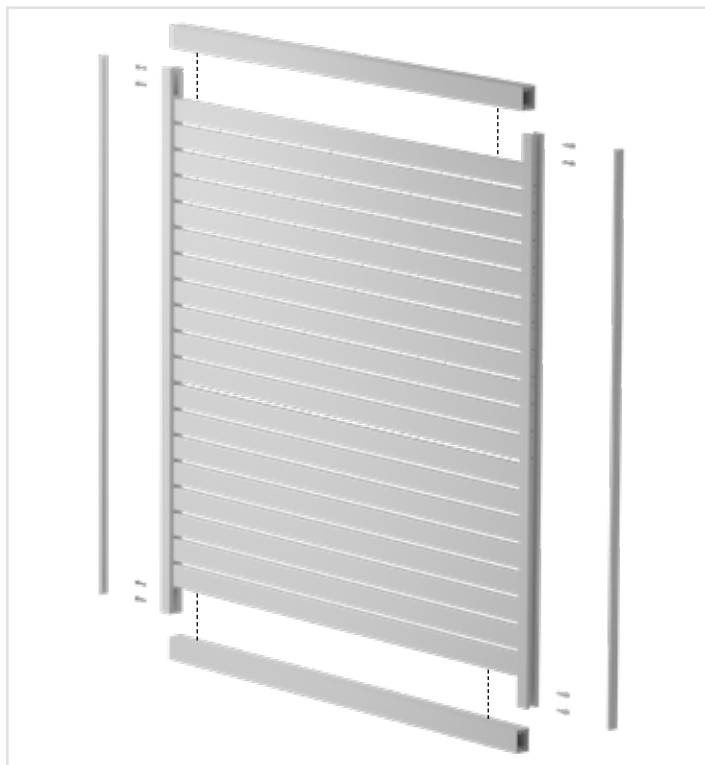

- 2 Once top/bottom rails and all slats are installed, ensure gate is square. The slimline brace must be measured and cut with an aluminium drop saw to run diagonally across the back face of the gate. Secure each slat using XP-SCREWS.

IMPORTANT:

Ensure the slimline brace is installed running from the 'bottom' hinge side corner to the top 'latch' side corner

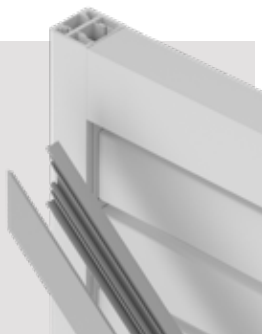

SUGGESTED HINGE FIXING METHOD USING 65MM M8 BOLTS, SPRING WASHERS & NUTS FOR GATES 1500MM AND UNDER

*Hinge fixings not supplied

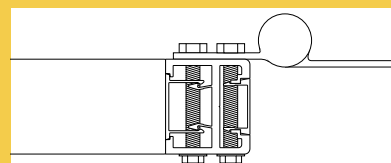

A complete range of hinges, latches & accessories

REFER PAGES 72-84



1
Long length supply

Buy long length extrusions then cut to size and assemble on-site or at your premises

2
Cut to size service

Simply provide gate size required – we will cut to size and flat pack for easy assembly

industry first, trade quality Sliding gates

AVAILABLE IN 2 CONVENIENT SUPPLY OPTIONS



Cut to size order forms for sliding gates

For cut to size orders, simply enter required height and width – our handy order form will then generate instant pricing for your order

We will then take your order, cut to size and flat pack for delivery Australia wide.



Sliding gate options

SELECT FROM A RANGE OF SLIDING GATE OPTIONS

We can cut to size, flat pack and send Australia wide or you can purchase long length extrusions and cut to size yourself

Assemble pre-powder coated sliding gates quickly and easily with no welding or riveting required

Save time and money without requirement of fully fabricating and welding

Contact us for detailed assembly instructions

1

Horizontal slat sliding gate

65mm x 16.5mm slats with 9mm or 20mm slat spacing

Patented 'no weld' gate side frames for fast assembly

Slats & frame imaged WRC or Kwila. Monument frame for Island Grey.

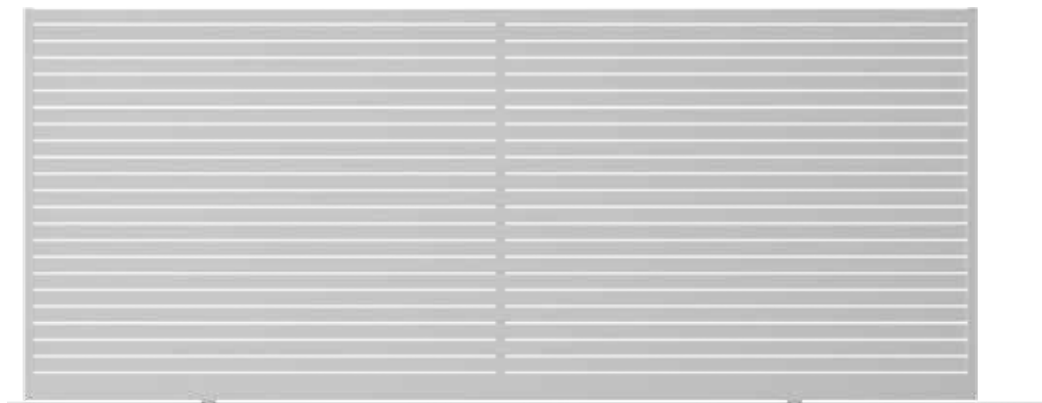

2

Horizontal slat sliding gate

65mm x 16.5mm or 90mm x 16.5mm slats

Variable slat spacing

Each slat required to be screw fixed

Slats & frame imaged WRC or Kwila. Island Grey slats with Monument powder coat framing.

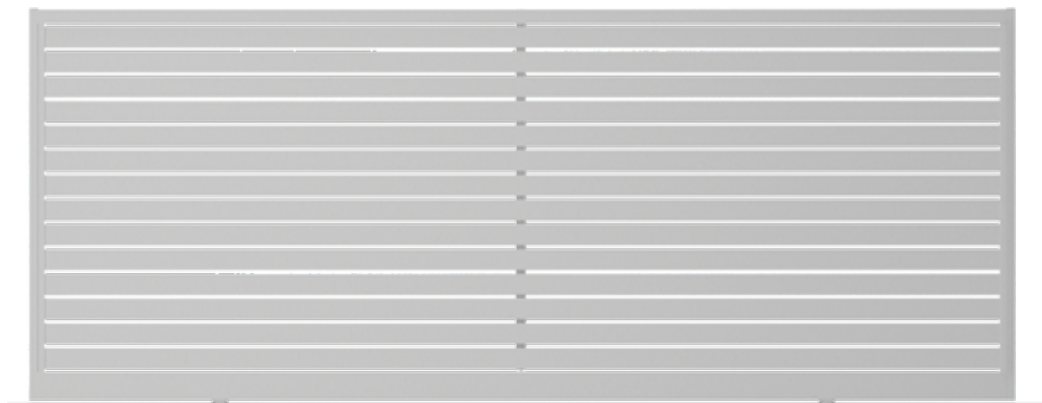

***WRC only available in 90x16.5mm slat**

3

Vertical slat sliding gate

65mm x 16.5mm or 90mm x 16.5mm slats

Variable slat spacing

Each slat required to be screw fixed

Slats & frame imaged WRC or Kwila. Island Grey slats with Monument powder coat framing.

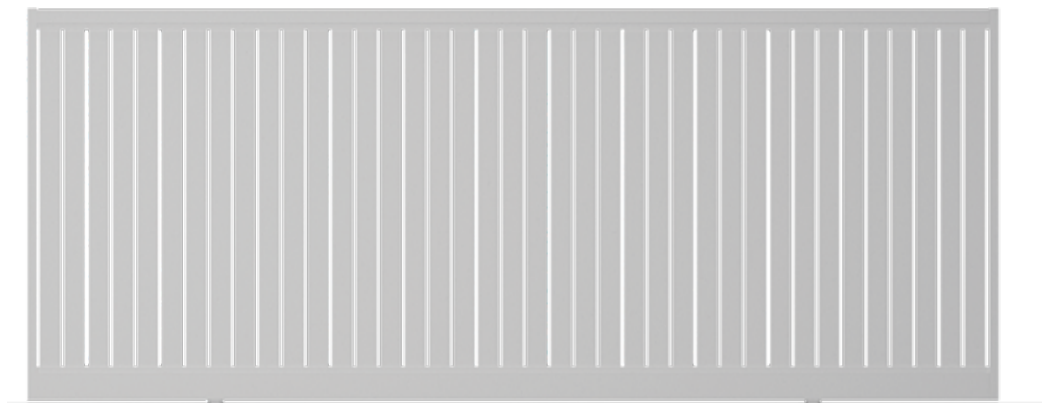

***WRC only available in 90x16.5mm slat**

SLIDING GATE OPTIONS

Option 1

Horizontal slat sliding gate with 65mm x 16.5mm slats
9mm or 20mm slat spacing
Patented 'no weld' side frames
Slats & frames timber imaged aluminium

SEE PAGES 143-149 FOR FULL SPECIFICATIONS ON ALL PRODUCTS LISTED BELOW

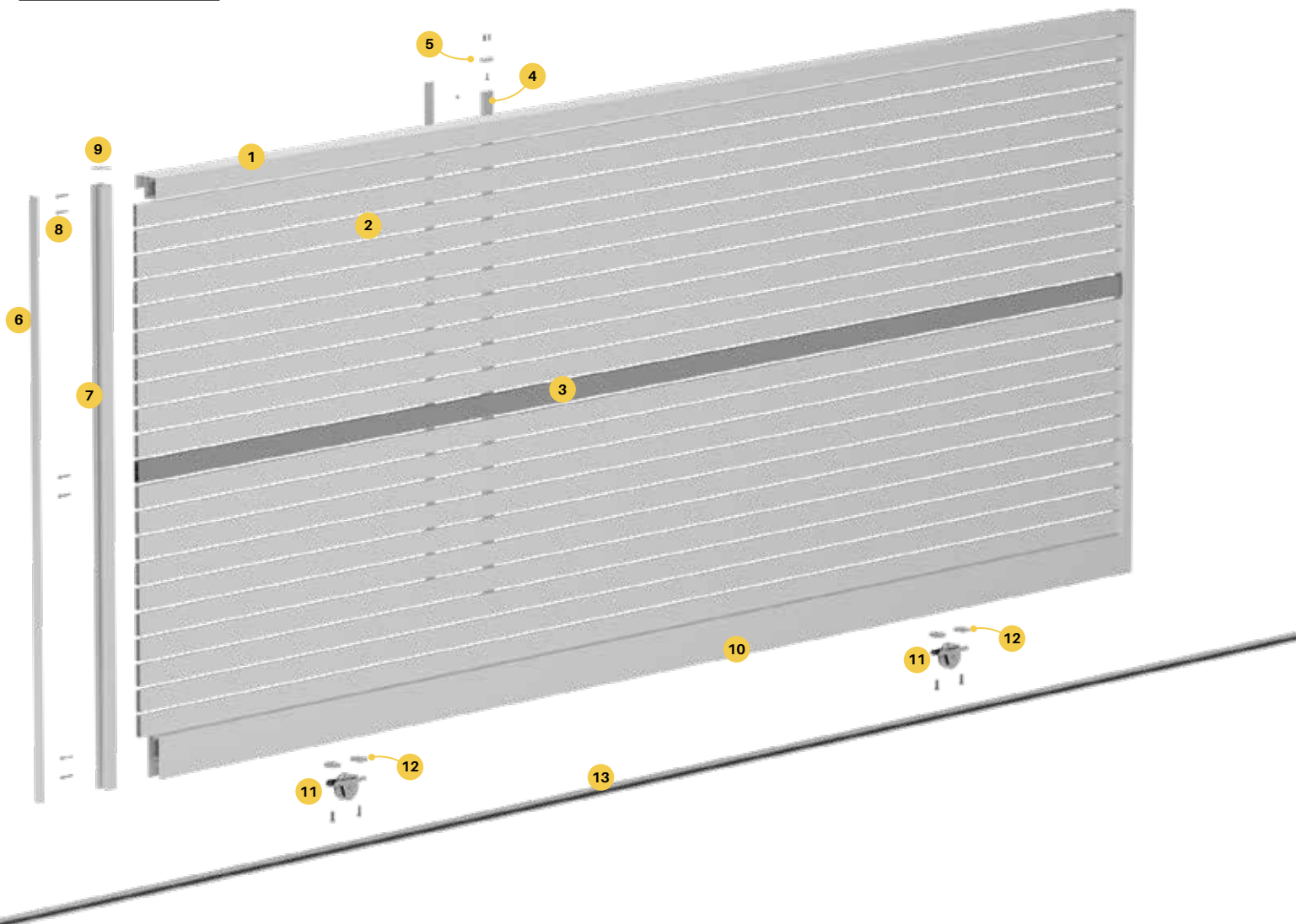

- | | | |
|--|--|--|
| <p>1 Top rail
Rail includes innovative side channel for slide guide or roller guide integration
Screw fix to side frames
AWSG-5800-TR</p> | <p>5 Top/bottom plate for centre support rail
Connects centre support rail to top and bottom rail for extra rigidity
AW-BTP</p> | <p>9 Gate frame cap
Presses into top of gate frames
XP-GFC-B</p> |
| <p>2 65x16.5mm slat
Standard slats held in place with patented friction fitting gate side frame
AW-5800-S65</p> | <p>6 Gate insert
Snaps into gate side frame to hide screw fixings
AWXP-4200-GI</p> | <p>10 Bottom Rail
Bottom rail features underside cavity for easy wheel recess fitting
Screw fixes to side frames
AWSG-5800-BR</p> |
| <p>3 65mm x 16.5mm gate slat with 2x screw flutes
Screw fluted slat at middle of gate provides extra rigidity
AW-5800-GB65</p> | <p>7 Gate side frames
Machined drill holes & slots
9mm or 20mm spacing
Suits 65x16.5mm slat
AWXP-4200-GSF09 or AWXP-4200-GSF20</p> | <p>11 Sliding gate wheel
80mm diameter wheel with 20mm diameter groove
XPSG-WHEEL</p> |
| <p>4 Centre support rail
Affixes to backside of gate slats
Screw fix each slat for extra support
Snap on cover hides all screws
AW-5800-CSR</p> | <p>8 Gate frame screws
12 gauge x 65mm long with flange hex head
Heavy duty screw fixing of side frame to top/bottom rail and gate blade
XP-SCREWSGF-10PK</p> | <p>12 Wheel clamping set
Clamps gate wheel to bottom rail
XPSG-WHEEL-CS</p> |
| | | <p>13 Gate track
Bolt down track with 20mm diameter running surface – Steel or aluminium
Consider anchor pins to secure track
XPSG-3000/6000-TRACK-ST or XPSG-6000-TRACK-AL</p> |

SLIDING GATE OPTIONS

Option 2

Horizontal slat gate with 65mm or 90mm x 16.5mm slats
Variable slat spacing including nil spacing. *WRC Only
Slats & frames timber imaged aluminium

SEE PAGES 143-149 FOR FULL SPECIFICATIONS ON ALL PRODUCTS LISTED BELOW

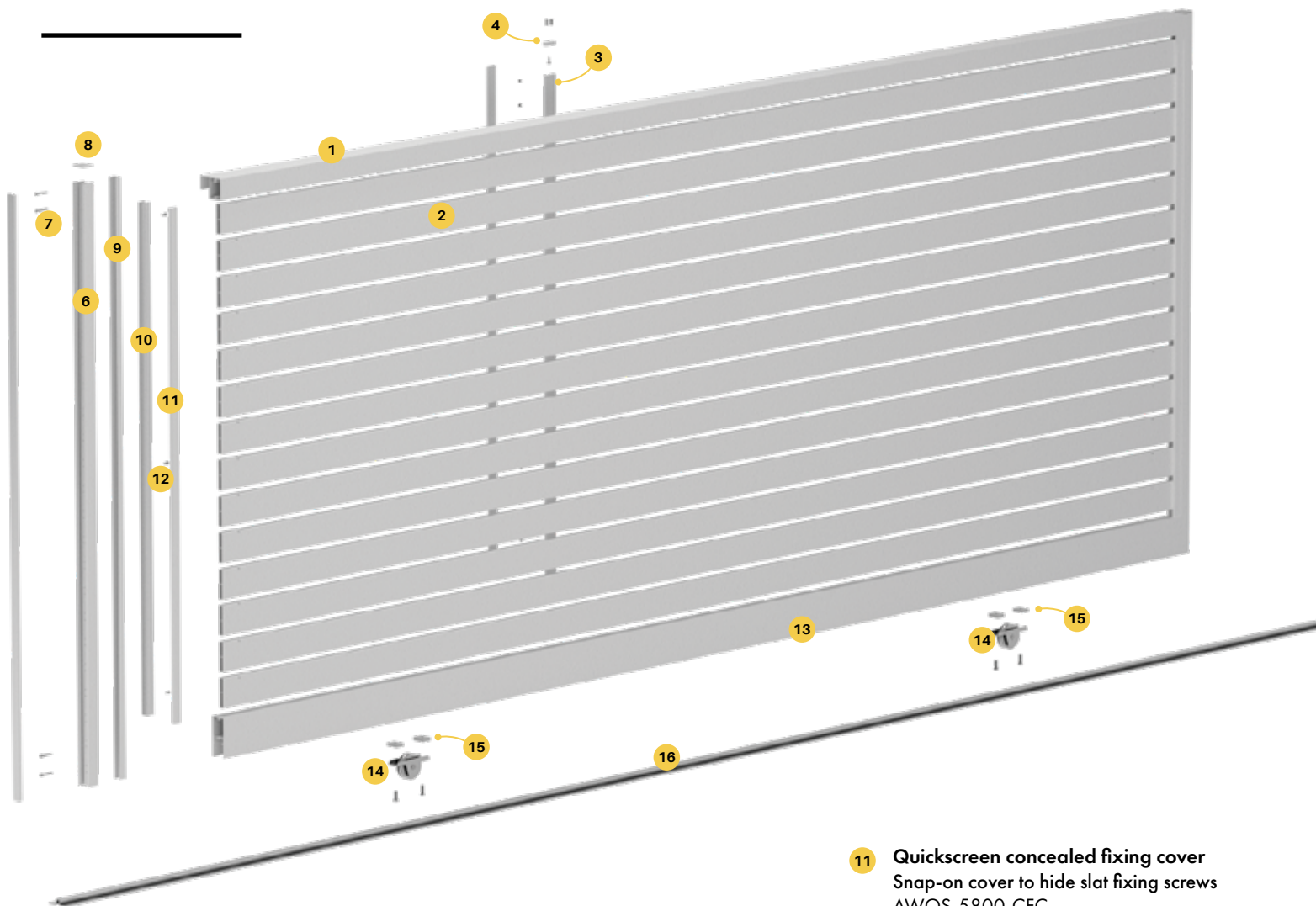

- 1 Top rail**
Rail includes innovative side channel for slide guide or roller guide integration
Screw fix to side frames
AWSG-5800-TR
- 2 65x16.5mm or 90x16mm slat**
Slats held in place with fixing screws
AW-5800-S65 / AWQS-5800-S90
- 3 Centre support rail**
Affixes to backside of gate slats
Screw fix each slat for extra support
Snap on cover hides all screws
AW-5800-CSR
- 4 Top/bottom plate for centre support rail**
Connects centre support rail to top and bottom rail for extra rigidity
AW-BTP
- 5 Gate insert**
Snaps into gate side frame to hide screw fixings
AWXP-4200-GI

- 6 Gate side frames**
Machined drill holes
AWXP-4200-GSF09 or AWXP-4200-GSF20
- 7 Gate frame screws**
12 gauge x 65mm long with flange hex head
Heavy duty screw fixing of side frame to top/bottom rail
XP-SCREWSGF-10PK
- 8 Gate frame cap**
Presses into top of gate frames
XP-GFC-B
- 9 Non-punched gate infill**
Replaces slotted infill from gate side frame
XP-XBAT-4200-INF
- 10 Quickscreen side frame**
Affix to inner face of gate side frame
Insert and screw off each slat
Variable slat spacing
AWQS-5800-SFC

- 11 Quickscreen concealed fixing cover**
Snap-on cover to hide slat fixing screws
AWQS-5800-CFC
- 12 Fixing screws**
Use to affix side frames and slats
All slats must be screw fixed to side frames
XP-SCREWS
- 13 Bottom Rail**
Bottom rail features underside cavity for easy wheel recess fitting
Screw fixes to side frames
AWSG-5800-BR
- 14 Sliding gate wheel**
80mm diameter wheel with 20mm diameter groove
XPSG-WHEEL
- 15 Wheel clamping set**
Clamps gate wheel to bottom rail
XPSG-WHEEL-CS
- 16 Gate track**
Bolt down track with 20mm diameter running surface – Steel or aluminium
Consider anchor pins to secure track
XPSG-3000/6000-TRACK-ST or XPSG-6000-TRACK-AL

SLIDING GATE OPTIONS

Option 3

Vertical slat gate with 65mm or 90mm x 16.5mm slats
Variable slat spacing including nil spacing
Slats & frames timber imaged aluminium

SEE PAGES 143-149 FOR FULL SPECIFICATIONS ON ALL PRODUCTS LISTED BELOW

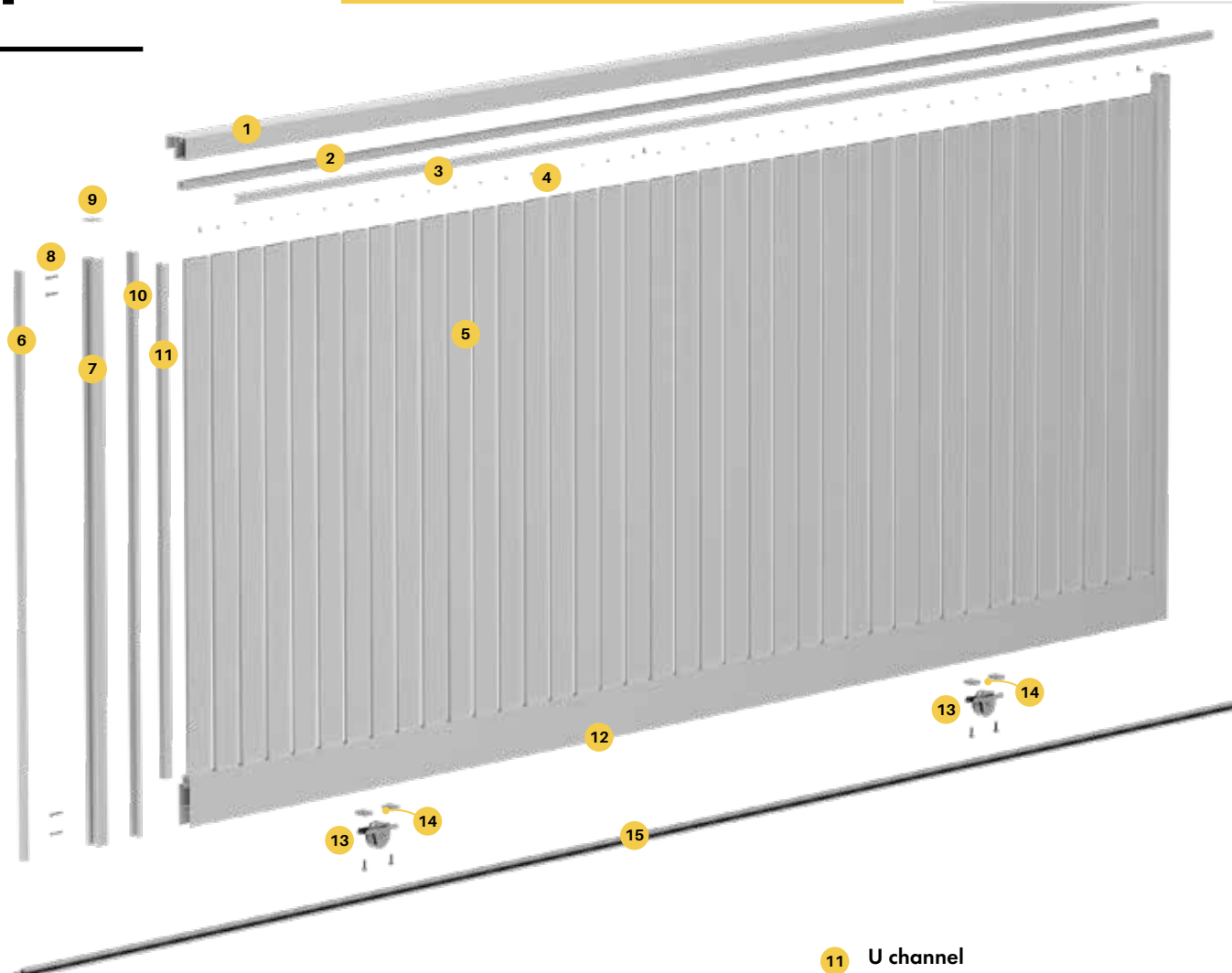

1 Top rail
Rail includes innovative side channel for slide guide or roller guide integration
Screw fix to side frames
AWSG-5800-TR

2 Quickscreen side frame
Affix to inner face of top/bottom rails
Insert and screw off each slat – variable spacing
AWQS-5800-SFC

3 Quickscreen concealed fixing cover
Snap-on cover to hide slat fixing screws
AWQS-5800-CFC

4 Fixing screws
Use to affix side frames and slats
All slats must be screw fixed to side frames
XP-SCREWS

5 65x16.5mm or 90x16mm slat
Slats held in place with fixing screws
AW-5800-S65 / AWQS-5800-S90

6 Gate insert
Snaps into gate side frame to hide screw fixings
AWXP-4200-GI

7 Gate side frames
Machined drill holes
AWXP-4200-GSF09 or AWXP-4200-GSF20

8 Gate frame screws
12 gauge x 65mm long with flange hex head
Heavy duty screw fixing of side frames to top/bottom rail
XP-SCREWSGF-10PK

9 Gate frame cap
Presses into top of gate frames
XP-GFC-B

10 Non-punched gate infill
Replaces slotted infill from gate side frame
XP-XBAT-4200-INF

11 U channel
Affix to vertical inner face of gate side frames. Reduces potential light gap on both vertical edges of gate
AWQS-5000-HORIZ

12 Bottom Rail
Bottom rail features underside cavity for easy wheel recess fitting
Screw fixes to side frames
AWSG-5800-BR

13 Sliding gate wheel
80mm diameter wheel with 20mm diameter groove
XPSG-WHEEL

14 Wheel clamping set
Clamps gate wheel to bottom rail
XPSG-WHEEL-CS

15 Gate track
Bolt down track with 20mm diameter running surface – Steel or aluminium
Consider anchor pins to secure track
XPSG-3000/6000-TRACK-ST or XPSG-6000-TRACK-AL

When calculating even spacing between vertical slats, overall gate width should be carefully considered to ensure first and last gap (between gate side frames and first/last slat) are kept uniform with other slat spacing

GATE EXTRUSIONS

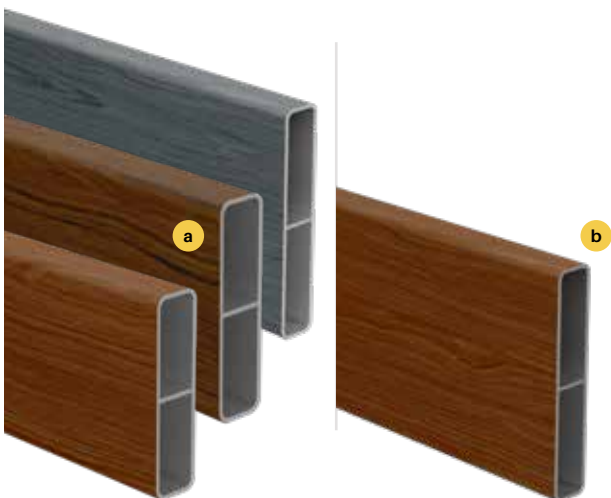

SLAT OPTIONS —

For full slat specification, see page 103

- a** 65x16.5mm slat with centre web
- b** 90x16.5mm slat with centre web



Sliding gate top rail

5800MM OR 6100MM LONG

Order Code: **AWSG-5800-TR**
XPSG-6100-TR-MN

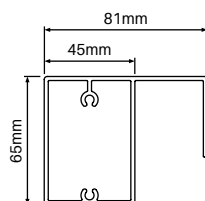

Finishes



KWILA
(KWI)



WESTERN
RED CEDAR
(WRC)



MONUMENT
(MN)
For Island Grey

TECH SPECS

- PP 293 / AP 367
- Alloy 6063 T5 / 5800mm long for WRC & Kwila finish
- Alloy 6063 T5 / 6100mm long for Monument finish
- 2.5mm wall thickness
- Top rail with innovative side channel for slide guide or roller guide integration
- Screw flutes incorporated for non-weld assembly
- lxx = 513.99 x 10E3 mmE4
- lyy = 404.97 x 10E3 mmE4

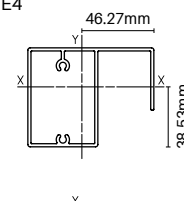

Sliding gate bottom rail

5800MM OR 6100MM LONG

Order Code: **AWSG-5800-BR**
XPSG-6100-BR-MN

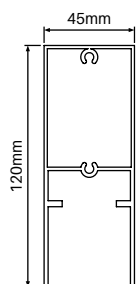

Finishes



KWILA
(KWI)



WESTERN
RED CEDAR
(WRC)



MONUMENT
(MN)
For Island Grey

TECH SPECS

- PP 332 / AP 476
- Alloy 6063 T5 / 5800mm long for WRC & Kwila finish
- Alloy 6063 T5 / 6100mm long for Monument finish
- 1.8mm wall top section with 2.5mm wall thickness bottom legs
- Bottom rail with underside cavity for wheel recess fitting
- Screw flutes incorporated for non-weld assembly
- lxx = 265.22 x 10E3 mmE4
- lyy = 994.41 x 10E3 mmE4

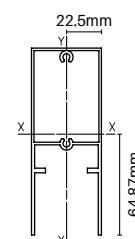

GATE EXTRUSIONS



9MM SPACING Slotted gate side frame

4200MM LONG

Order Code: **AWXP-4200-GSF09**
XP-4200-GSF09-MN

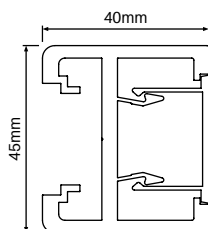

Finishes

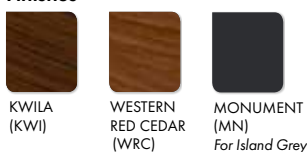

TECH SPECS

- PP 170
- Alloy 6063-T5 / 4200mm long
- 3mm wall thickness with 3.8mm centre crossmember
- Slotted insert to suit 65x16.5mm slat with 9mm spacing
- Patented frame for friction insertion of slats
- Crossmember machined with drill holes along entire length to suit screw fixing of top & bottom rail as well as centrally located 'gate' slat
- lxx = 6.294 x 10E3 mmE4
- lyy = 152.403 x 10E3 mmE4

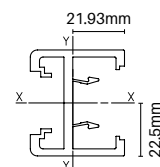

20MM SPACING Slotted gate side frame

4200MM LONG

Order Code: **AWXP-4200-GSF20**
XP-4200-GSF20-MN

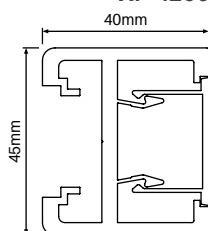

Finishes

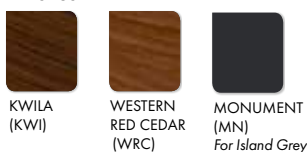

TECH SPECS

- PP 170
- Alloy 6063-T5 / 4200mm long
- 3mm wall thickness with 3.8mm centre crossmember
- Slotted insert to suit 65x16.5mm slat with 20mm spacing
- Patented frame for friction insertion of slats
- Crossmember machined with drill holes along entire length to suit screw fixing of top & bottom rail as well as centrally located 'gate' slat
- lxx = 6.294 x 10E3 mmE4
- lyy = 152.403 x 10E3 mmE4

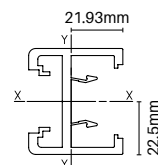

Snap-in gate insert

4200MM LONG

Order Code: **AWXP-4200-GI**
XP-4200-GI-MN

MATES WITH AWXP-4200-GSF09/20
XP-4200-GSF09/20

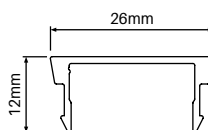

Finishes



TECH SPECS

- PP 100 / AP 100
- Alloy 6060-T5 / 4200mm long
- Snap-in gate insert mates with gate side frame
- Hides screws required for fixing of top & bottom rail and 'gate' slats
- lxx = 0.86 x 10E3 mmE4
- lyy = 5.93 x 10E3 mmE4

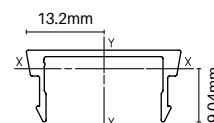

GATE EXTRUSIONS



NON-PUNCHED Gate infill

4200MM LONG

Order Code: **AWXP-XBAT-4200-INF**
XP-XBAT-4200-INF-MN

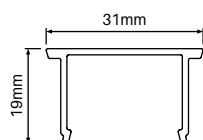

Finishes



KWILA
(KWI)



WESTERN
RED CEDAR
(WRC)



MONUMENT
(MN)
For Island Grey

TECH SPECS

- PP 100 / AP 133
- Alloy 6060-T5 / 4200mm long
- Non-punched snap-in infill for gate side frames
- Required when making vertical slat sliding gates, variable spaced horizontal slat gates or gates using 90mm x 16.5mm slats
- Replace existing slotted infill in gate side frame with non-punched gate infill if required
- $l_{xx} = 2.94 \times 10E3 \text{ mmE4}$
- $l_{yy} = 9.50 \times 10E3 \text{ mmE4}$

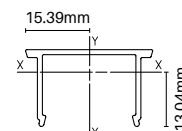

Side frame

5800MM LONG

Order Code: **AWQS-5800-SF**
QS-5800-SF-MN

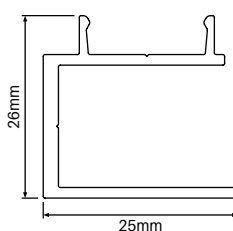

Finishes



KWILA
(KWI)



WESTERN
RED CEDAR
(WRC)



MONUMENT
(MN)
For Island Grey

TECH SPECS

- PP 104 / AP 156
- Alloy 6063-T6 / 5800mm long
- Used for sliding gates with horizontal variable slat spacing and also vertical slat sliding gates
- Each slat must be screw fixed to side frame
- Affix side frame to 45mm x 40mm gate frame
- $l_{xx} = 9.58 \times 10E3 \text{ mmE4}$
- $l_{yy} = 8.38 \times 10E3 \text{ mmE4}$

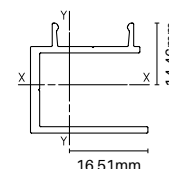

Concealed fixing cover

5800MM LONG

Order Code: **AWQS-5800-CFC**
QS-5800-CFC-MN

**MATES WITH AWQS-5800-SF
QS-5800-SF**

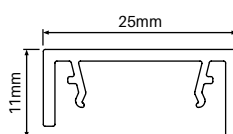

Finishes



KWILA
(KWI)



WESTERN
RED CEDAR
(WRC)



MONUMENT
(MN)
For Island Grey

TECH SPECS

- PP 100 / AP 116
- Alloy 6060-T5 / 5800mm long
- Snap-on cover for Alumawood side frame
- Hides screws used to affix slats to side frame
- $l_{xx} = 0.71 \times 10E3 \text{ mmE4}$
- $l_{yy} = 6.58 \times 10E3 \text{ mmE4}$

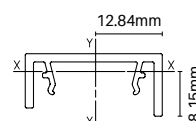

GATE EXTRUSIONS



Heavy duty U channel

5000MM LONG
Order Code: **AWQS-5000-HORIZ**
QS-5000-HORIZ-MN

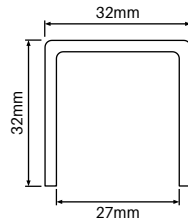

FOR VERTICAL SLAT

Finishes



KWILA
(KWI)



WESTERN
RED CEDAR
(WRC)



MONUMENT
(MN)
For Island Grey

TECH SPECS

- PP 184 / AP 184
- Alloy 6060-T5
- 5000mm long
- Required for vertical slat sliding gates only. Use on both internal vertical sides to reduce light gaps at gate edges
- 2.5mm wall thickness
- $l_{xx} = 23.97 \times 10E3 \text{ mmE4}$
- $l_{yy} = 38.92 \times 10E3 \text{ mmE4}$

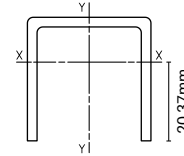

65mm x 16.5mm gate slat with centre web & 2x screw flutes

5800MM LONG
Order Code: **AW-5800-GB65**
XP-6100-GB65-MN

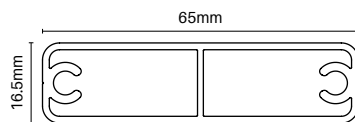

Finishes



KWILA
(KWI)



WESTERN
RED CEDAR
(WRC)



ISLAND GREY
(IG)

TECH SPECS

- PP 158 / AP 158
- Alloy 6063-T6
- 5800mm long
- 1.5mm wall thickness with 1.2mm wall centre web
- 2x screw flutes
- Interpon base coat: Italian image film
- Used in strategic positions for horizontal sliding gate assembly
- Non weld assembly using 12 gauge screws into screw flutes (Code: XP-SCREWSGF-10PK)
- $l_{xx} = 11.85 \times 10E3 \text{ mmE4}$
- $l_{yy} = 144.09 \times 10E3 \text{ mmE4}$

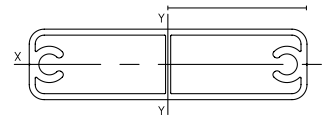

Centre support rail

5800MM LONG
Order Code: **AWXP-5800-CSR**
XP-5800-CSR-MN

OPTIONAL EXTRA

Snap-on cover hides fixings – provides slimline sturdy support rail with no visible fixings

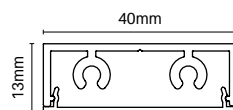

Finishes



KWILA
(KWI)



WESTERN
RED CEDAR
(WRC)



MONUMENT
(MN)
For Island Grey

TECH SPECS

- PP 126 / AP 188
- Alloy 6063-T5
- 5800mm long
- Screwing fix centre support rail provides support to slats used in horizontal sliding gates
- For extra rigidity, centre support rail is braced to the top & bottom rail
- $l_{xx} = 1.73 \times 10E3 \text{ mmE4}$
- $l_{yy} = 26.34 \times 10E3 \text{ mmE4}$

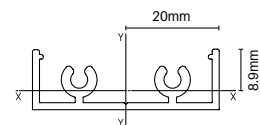

GATE EXTRUSIONS

65x65mm steel post

2700MM LONG

Order Code: XPSG-2700-ST65-B

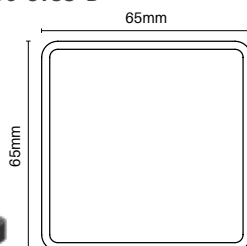

BLACK
(B)



MONUMENT
(MN)
For Island Grey

TECH SPECS

- 65x65mm galvanised steel post
- Includes press in black cap
- 2.5mm wall thickness
- Use at gate end to affix guide rollers or slide guide
- May also be used at gate front for affixing U or F catch
- Includes welded on 8mm thick base plate with 2 x 12.8mm diam fixing holes - use for base plated post fixing or bury into concrete for superior anchoring

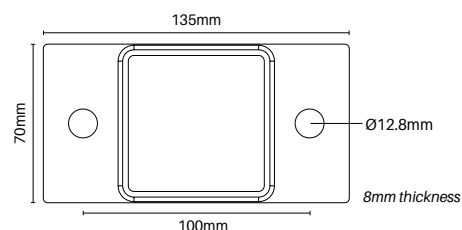

Sliding gate extension

400MM LONG

Order Code: AWSG-MXTN-KIT
XPSG-MXTN-KIT-MN

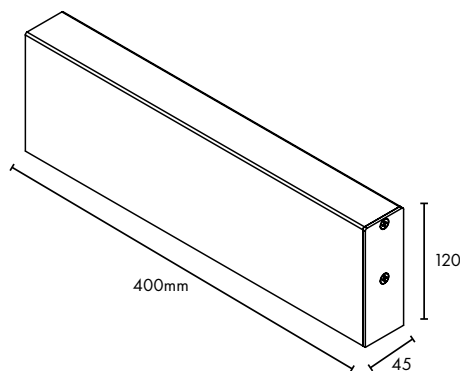

Finishes



KWILA
(KWI)



WESTERN
RED CEDAR
(WRC)



MONUMENT
(MN)
For Island Grey

TECH SPECS

- 400mm long bottom rail extension
- Optional extra - useful where extra length required for motor rack to be affixed to bottom rail.
- Not required for every slide gate install. Recommended only where install situation requires
- Extension piece fixes to gate side frame
- Fixing bolts and plates included in kit
- Bottom rail is timber imaged with terrain powder coat end plate

Simply bolt onto bottom of gate side frame during assembly process

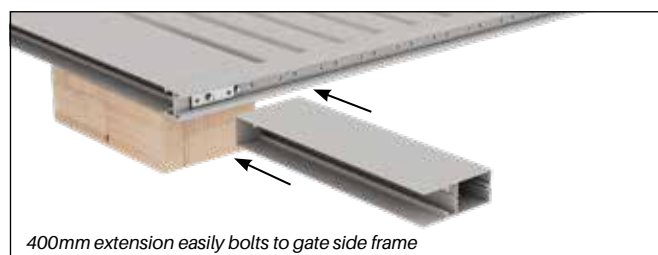

GATE ACCESSORIES

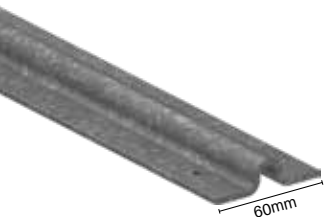

Steel sliding gate track

3000MM LONG OR
6000MM LONG

Order Codes:

XPSG-3000-TRACK-ST (3000mm)

XPSG-6000-TRACK-ST (6000mm)

- Available 3000mm or 6000mm long
- Made from 3mm galvanised steel for durability
- Bolt down sliding gate track with a $\varnothing 20$ mm running surface
- Easy to install with predrilled fixing holes (22 holes for 3000mm track and 42 holes for 6000mm track)

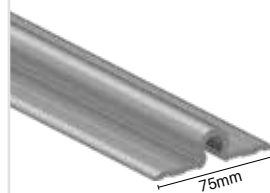

Aluminium sliding gate track

6000MM LONG

Order Code:

XPSG-6000-TRACK-AL (6000mm)

- Available 6000mm long
- Mill finish aluminium - 6063-T5
- Bolt down sliding gate track with a $\varnothing 20$ mm running surface
- No drill holes - drill fixing holes as needed



Sliding gate track pins

Order Code: **XPSG-ANCHOR**

- Mushroom head galvanised steel track anchor pins
- 6.5mm x 38mm
- Pre-expanded expansion anchor. Once hammered in, unique kinked shaft provides a spring action for vibration proof anchoring. Use 6.5mm masonry bit into concrete



Sliding gate wheel

Order Code: **XPSG-WHEEL**

- 80mm diameter with 20mm diameter groove
- Zinc plated steel
- Load rating 180kg
- Use with 1 x XPSG-WHEEL-CS clamping set to fix to sliding gate bottom rail
- Made in Italy



Sliding gate wheel clamping set

Order Code: **XPSG-WHEEL-CS**

- Use to clamp sliding gate wheel to bottom rail
- Aluminium M8 threaded block
- Includes 2 x zinc plated screws
- Sold as a pack of 2 (suits 1 x wheel)



Slide guide

Order Code: **XPSG-GUIDE**

- Self-adjusting slide guide attaches to sliding gate top rail
- Keeps gate in vertical position and travelling true while opening/closing
- As gate travels along track and shifts up or down, slide guide adjusts automatically. Up to 280mm vertical adjustment.
- Guide channel is anodised black with sturdy nylon block

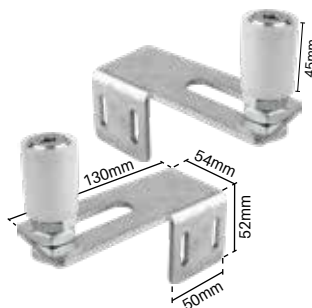

Sliding gate guide rollers

2 PACK

Order Code: **XPSG-TOPROLL-2PK**

- Alternative to SlideGuide
- Rollers guide top rail while gate opens and closes
- Can only be used if vertical deviation of gate while travelling is 15mm or less
- White nylon rollers - made in Italy
- Kit includes 1 x left and 1 x right zinc plated steel mounting bracket (fixings not included) - 30mm hole centers

2 installation methods —

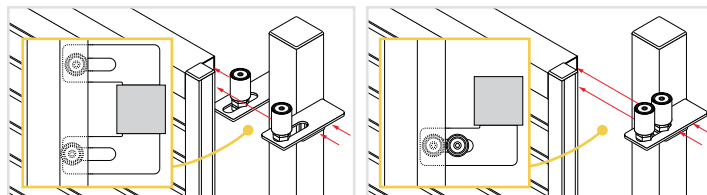

GATE ACCESSORIES



Gate U catch

Order Code: XPSG-CATCH-U

- Suits up to 50mm gate frames
- Gate catch supplied with 5 pre-drilled holes for easy installation and adjustment
- Rubber stop provided for noise reduction
- Steel zinc plated



Gate F catch

Order Code: XPSG-CATCH-F

- Suits up to 50mm gate frames
- Affix bracket to wall/post via "F" leg
- U catch attaches to F section – includes rubber stop for noise reduction
- U catch horizontally adjustable for ease of lining up to gate frame
- Steel zinc plated



Gate stop

Order Code: XPSG-STOP

- Stops the gate in the option position
- Forged steel zinc plated gate stop with nylon bumper
- Bolts to concrete at end of gate track. 4x Ø11mm fixing holes
- Made in Italy

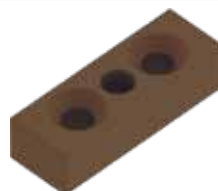

MATES WITH AWXP-5800-CSR
XP-5800-CSR



MONUMENT (MN)
For Island Grey

Centre support rail top/ bottom plate

Order Code: AW-BTP-TR
XP-BTP-MN

- Aluminium with countersunk hole machining
- Terrain finish suits WRC & Kwila. Monument suits Island Grey
- Use to brace off top and/or bottom of centre support rail to top and bottom rails
- Bracing centre support rail provides extra rigidity



Screw top/bottom plate to centre support rail



Screw through central hole to top & bottom rail



Gate frame cap

NYLON

Black / Monument

Order Code: XP-GFC-B

- UV stabilised nylon – 3mm thick cap
- Black screen heads suit WRC & Kwila. Monument suits Island Grey
- Suits gate side frame
- Press-in flat cap



BLACK (B)



MONUMENT (MN)
For Island Grey



PACK OF 10 Gate frame screws

12Gx65MM HEX FLANGE HEAD

Order Code: XP-SCREWSGF-10PK

- Hex flange head for easy assembly
- Use to screw horizontal top & bottom rails to vertical side frames
- Also use to screw fix 'gate' slat to side frames for horizontal slat gates with 9mm or 20mm spacing (65x16.5mm slats)



Self drilling wafer screws

10Gx16MM – BAG OF 100

Black / Monument

Order Code: XP-SCREWS-B/MN

- 10G x 16mm self drilling wafer head zinc plated
- Powder coated heads for neat finish
- Use to: (1) Screw fix centre support rail to slats
(2) Screw fix & brace off centre support rail top/bottom plate to top/bottom rail
(3) Screw fix slats to side frames if required
(4) Attach Alumawood side frame to outer gate frame for gate options 2 & 3
(see pages 141-142)

Sliding gate motors



LONG TERM RELIABILITY

NiceHome automation and accessories are tested every day in the Nice laboratories according to strict criteria. To ensure compliance with the strictest safety requirements on the market, NiceHome guarantees the highest possible technological and quality standards.

PROFESSIONAL QUALITY

Designed and manufactured in Italy, NiceHome automation benefits from unique Italian know-how combining top performance with an essential style to adapt perfectly to the needs of your home.

To complement horizontal slat and vertical slat sliding gates, GO can supply the highest quality Italian made gate automation and accessories. NiceHome automation is a new upgrade to the well-known Mhouse range.



Filo 400 Pro Kit

Order Code: XPSG-FILO-400

KIT INCLUDES:

- 1x Motor
- 2x Remotes
- 1x Pair of Photocells (safety device which prevents the gate from closing on pedestrians or vehicles)

- Sliding gate opener suits gates up to 6000mm wide and weighing up to 400kg
- Easy to install and simple programming steps
- Flexible short power cord pre-wired to motor
- Plugs into standard power point with 10 amp flat 3 pin plug
- Includes pinion (cog) that integrates with rack on gate

Low voltage cable option

FILO 400 Pro Kit with split pack

Features external transformer

Order Code: XPSG-FILO-400PRO-SP

- Same motor and accessories as FILO 400 except transformer is separated from motor
- External transformer converts 240V mains power to low voltage 24V
- Use 2 core x 2.5mm (double insulated) electrical cable to run from transformer to motor. CABLE SOLD SEPARATELY - can be purchased from electrical wholesaler or reputable hardware store
- Motor can be installed a maximum of 50 meters away from transformer
- 10 amp flat 3 pin plug
- Ideal where getting 240V mains power to gate motor is difficult. Simply run low voltage cable from transformer to gate motor.
- Refer www.easygate.com.au for technical assistance/manuals

KIT INCLUDES:

- 1x Motor
- 2x Remotes
- 1x Pair of Photocells (safety device which prevents the gate from closing on pedestrians or vehicles)
- 1x External transformer in weatherproof enclosure



External transformer

MOTOR ACCESSORIES



Remote control

Order Code: XPSG-FILO-REMOTE

- Optional extra remote control to replace remotes in kit if broken or more remotes required (2x remotes included as standard with each motor kit)
- 5 channel remote able to control various gate functions (eg open only, close only, partial open etc)



Wireless keypad

Order Code: XPSG-FILO-WKP

- Optional wireless keypad for gate motor opening/closing
- PIN number control access
- Easy to affix to wall or post
- Runs on 2 x CR2430 lithium batteries



Solar power kit

Order Code: XPSG-FILO-SOLAR

- Solar power system designed for use with NiceHome motors
- System uses exclusively solar power to run automation without use of electrical mains power
- Provides continuous electrical energy. Ideal for sites where mains power is unavailable
- Includes photovoltaic panel (converts solar energy into electrical energy) and electric battery (for stored power, able to operate gate night and day)
- Attention must be paid to ensure panel positioned to receive full sunshine



Backup battery

Order Code: XPSG-FILO-BATTERY

- Optional battery provides backup power in the event of mains power failure
- Gate can be cycled multiple times under battery power (no. of cycles may vary due to gate size and site conditions)
- Backup battery is recharged under mains power



Rack

Order Code: XPSG-FILO-RACK

- Tough & durable nylon rack (with steel core)
- Affix to bottom rail of sliding gate
- 1 meter long sections; 6 fixing points
- Quieter than steel racks
- Made in Italy

TECHNICAL ASSISTANCE/MANUALS AND SUPPORT VIDEOS

www.easygate.com.au

EQUIPMENT ENCLOSURE



A SOPHISTICATED & STYLISH EQUIPMENT CLOSURE!
 IDEAL FOR SCREENING OF POOL FILTERS,
 RUBBISH BINS & AIR CONDITIONERS

65mm aluminium horizontal slat available in 10 finishes. A complete solution including door, hardware & lid with gas struts. Custom cut to size & flat packed for easy assembly.
 Simple to assemble without the need of welding!

Available
 in 10
 finishes!



EQUIPMENT ENCLOSURE



CUSTOM CUT TO SIZE
– SIMPLY PROVIDE
REQUIRED SIZES



FLAT PACKED –
EASILY TRANSPORTED
READY FOR ASSEMBLY



AVAILABLE
IN 10 FINISHES



HUGE SAVINGS VS
TRADITIONALLY FULLY
WELDED SYSTEM



AUSTRALIA WIDE
DELIVERY – FREE DELIVERY
TO METRO CAPITALS*
*Excludes Darwin & Hobart

With lid



Available
with open or
closed back!

Available
with or without
lid! Perfect for
storing bins.

Without lid

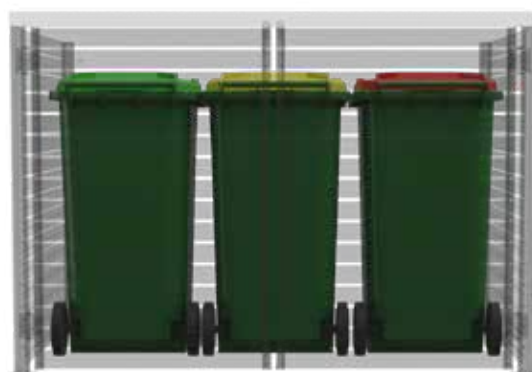

SYSTEM OVERVIEW

LID CAN BE OPENED AND CLOSED.
IN THE CLOSED POSITION, LID TILTS FORWARD FOR
RAIN/WATER TO DRAIN AWAY.
ALSO AVAILABLE WITHOUT LID.

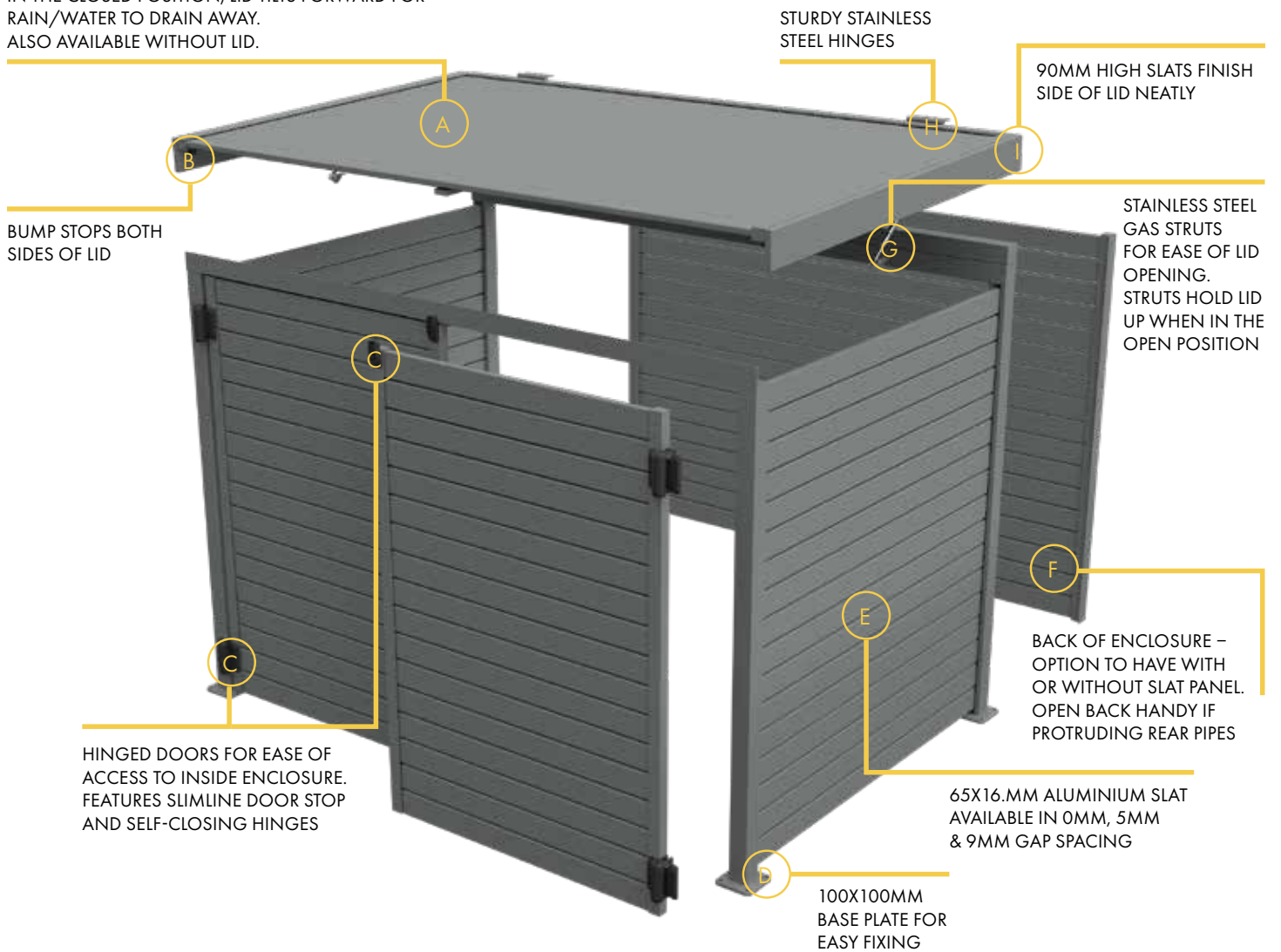

EQUIPMENT ENCLOSURE

Custom cut
to size with easy
onsite assembly!
No welding needed.





LETTERBOXES

Hamptons Letterbox

WHITE OR CHARCOAL
LETTERBOX

Order Code: HF-LETTERBOX-CH (Charcoal)
HF-LETTERBOX-W (White)

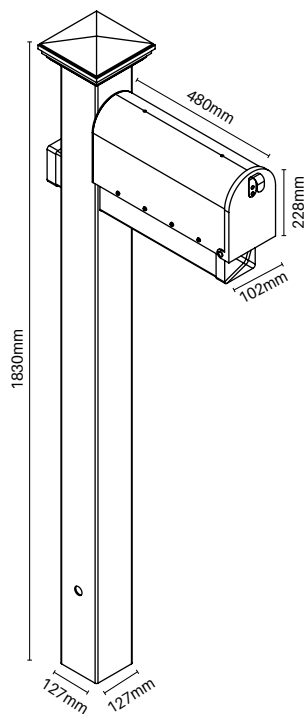

TECH SPECS

- Complete kit in 1 x box ready for easy assembly
- Kit includes post, horizontal arm, letterbox & assembly screws
- 1830mm high white PVC post for in-ground installation
- Internal base plate can be used if installing onto concrete. Use base plate (HF-FULLP-BP- refer pg 11)
- Letterbox made from durable powder coated steel
- Refer www.productinstall.com.au/hampsons (password: hampsons1) for guidance on assembly & installation

KIT INCLUSIONS

- 1 x Vertical Post (1830mm H x 127mm W x 127mm D)
- 1 x Horizontal Arm (610mm L x 102mm W x 102mm D)
- 1 x Powder Coated Steel Mailbox (480mm L x 164mm W x 228mm H)
- 1 x Mounting Plate (380mm L x 155mm W x 25mm H)
- 1 x Post Cap & 2 x Horizontal Arm Caps
- 12 x Assembly screws

POSTA

New!

POSTA fence mount letterbox

White, Black powder coat or SS316 finishes

410mm H x 230mm W

Order Code: **POSTA-FML-W**
POSTA-FML-B
POSTA-FML-SS316

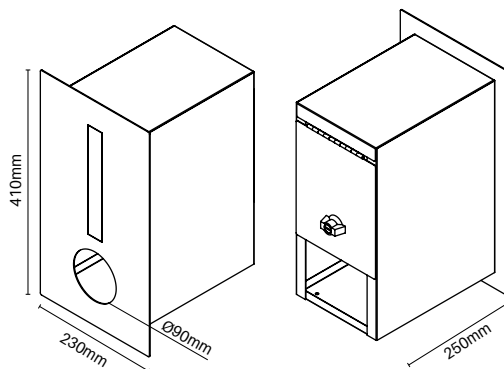
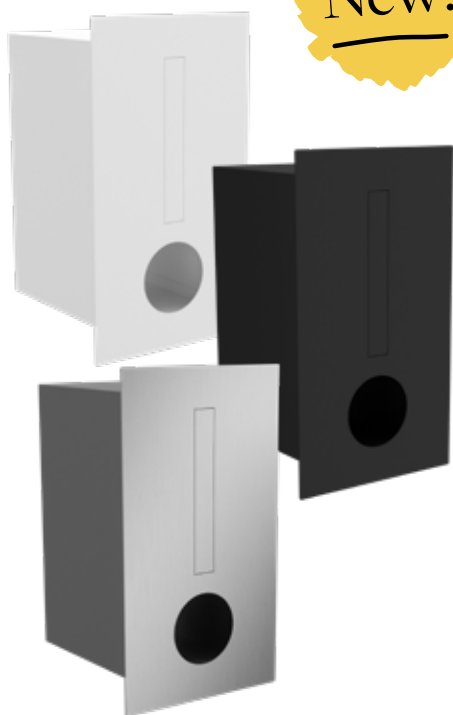

TECH SPECS

- Modern design
- Powder-coated galvanised steel letterbox in black or white finish. Also available in Stainless Steel satin finish 316 marine grade front panel with powder-coated grey galvanised box.
- Newspaper holder built in
- Rain resistant flap
- Includes key lock & keys
- Includes all mounting fittings & assembly instructions
- Posts, slat & sideframes sold separately



NOTE: Features a sleeve for easy fixing to fence.

Scan QR code for detailed install instructions
PWD - Posta 1



CONTACT US FOR EXCEL ORDER FORM

WE CAN CUSTOM CUT TO SIZE POST & SLATS TO MIX-&-MATCH WITH POSTA LETTERBOX



TYPICAL CONFIGURATION

POSTA SLAT LETTERBOX INSTALL GUIDE

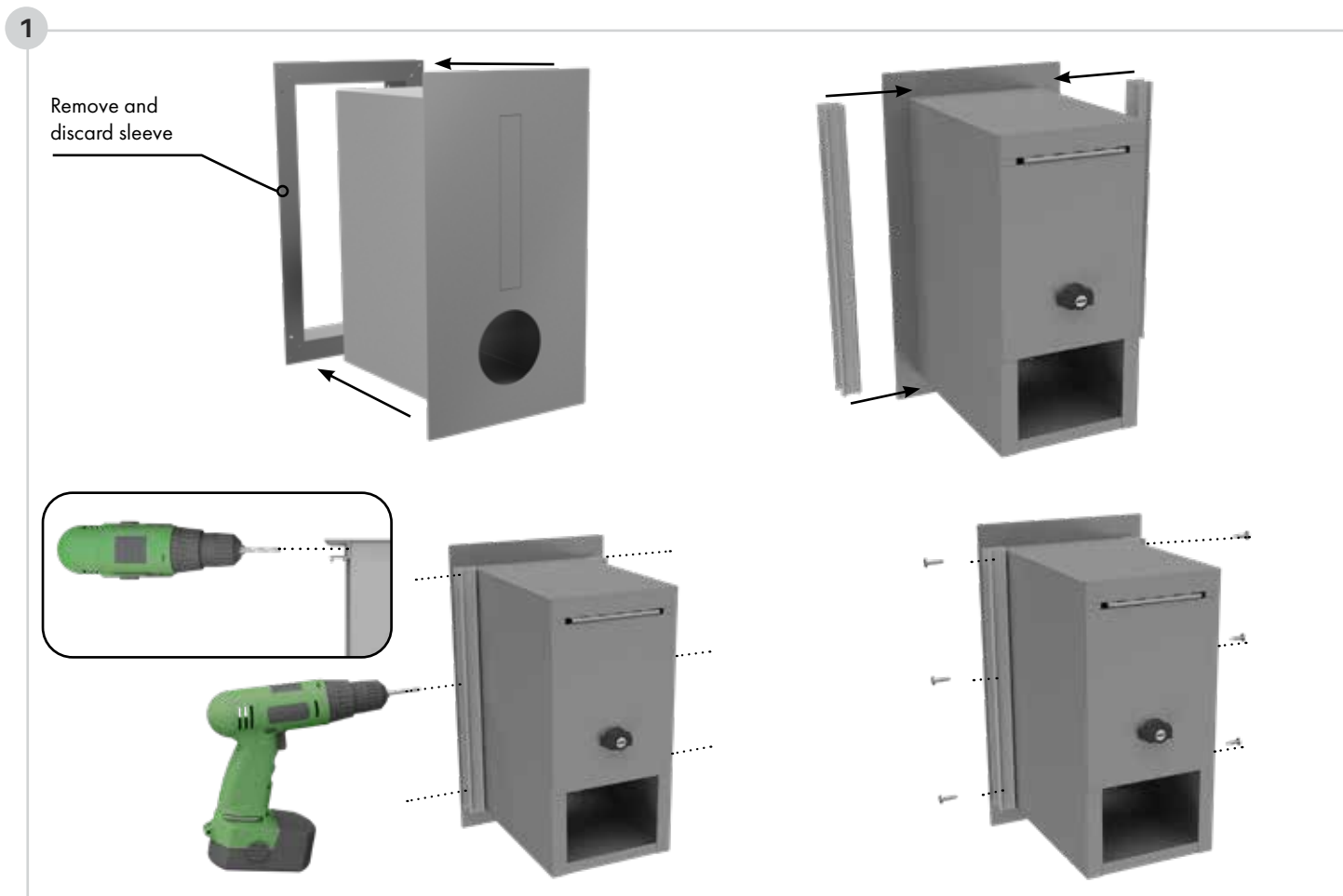

Remove and discard sleeve.

Attach Quickscreen Side Frame to either side of the Letterbox box, directly behind the face-plate using 3.5mm pilot holes and 6 x 10G x 18mm screws (from Quickscreen kit).

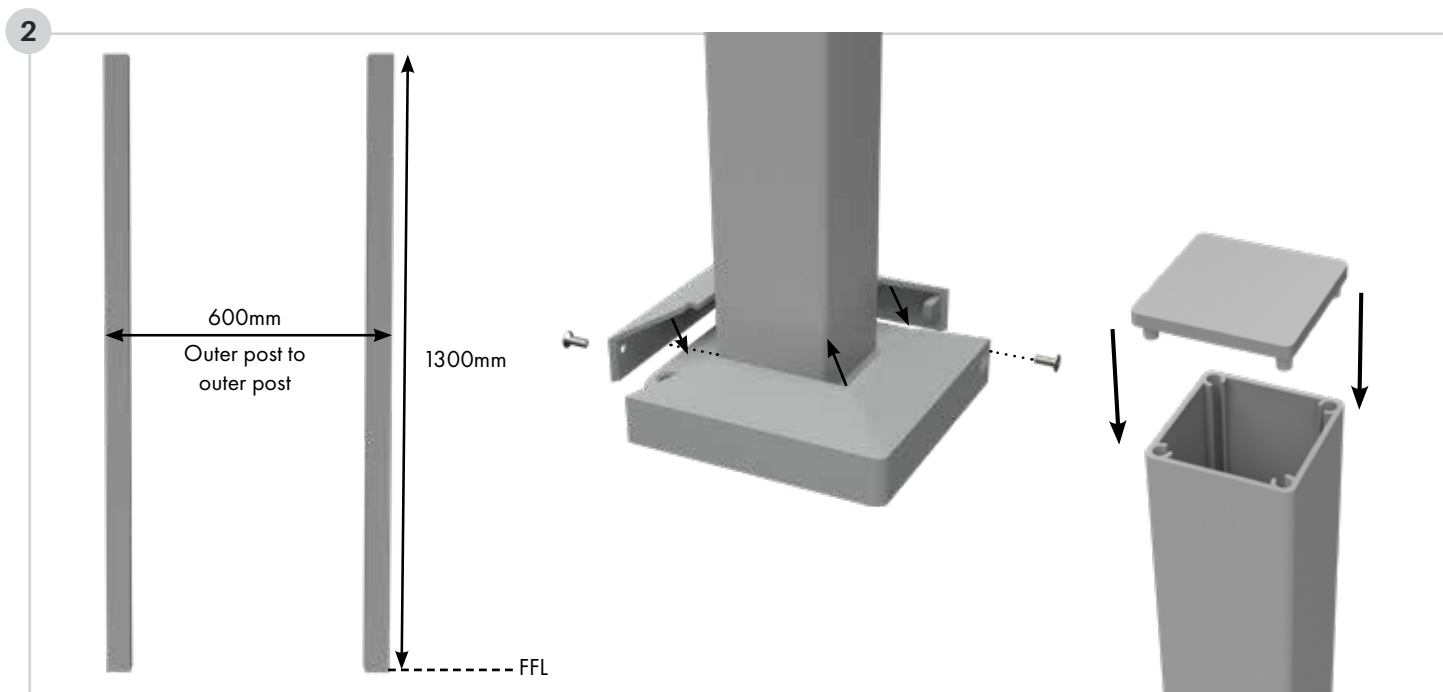

Install 50x50mm posts level at 600mm apart (post outer to post outer) at 1300mm high above finished floor level (FFL).

If posts are installed in-ground, ensure they are embedded appropriately. A minimum of 300mm wide x 300mm deep concrete footing for each post is recommended. Fit 2 x Domical Covers (if base-plate posts are used).

Insert caps into tops of posts.

TYPICAL CONFIGURATION

POSTA SLAT LETTERBOX INSTALL GUIDE

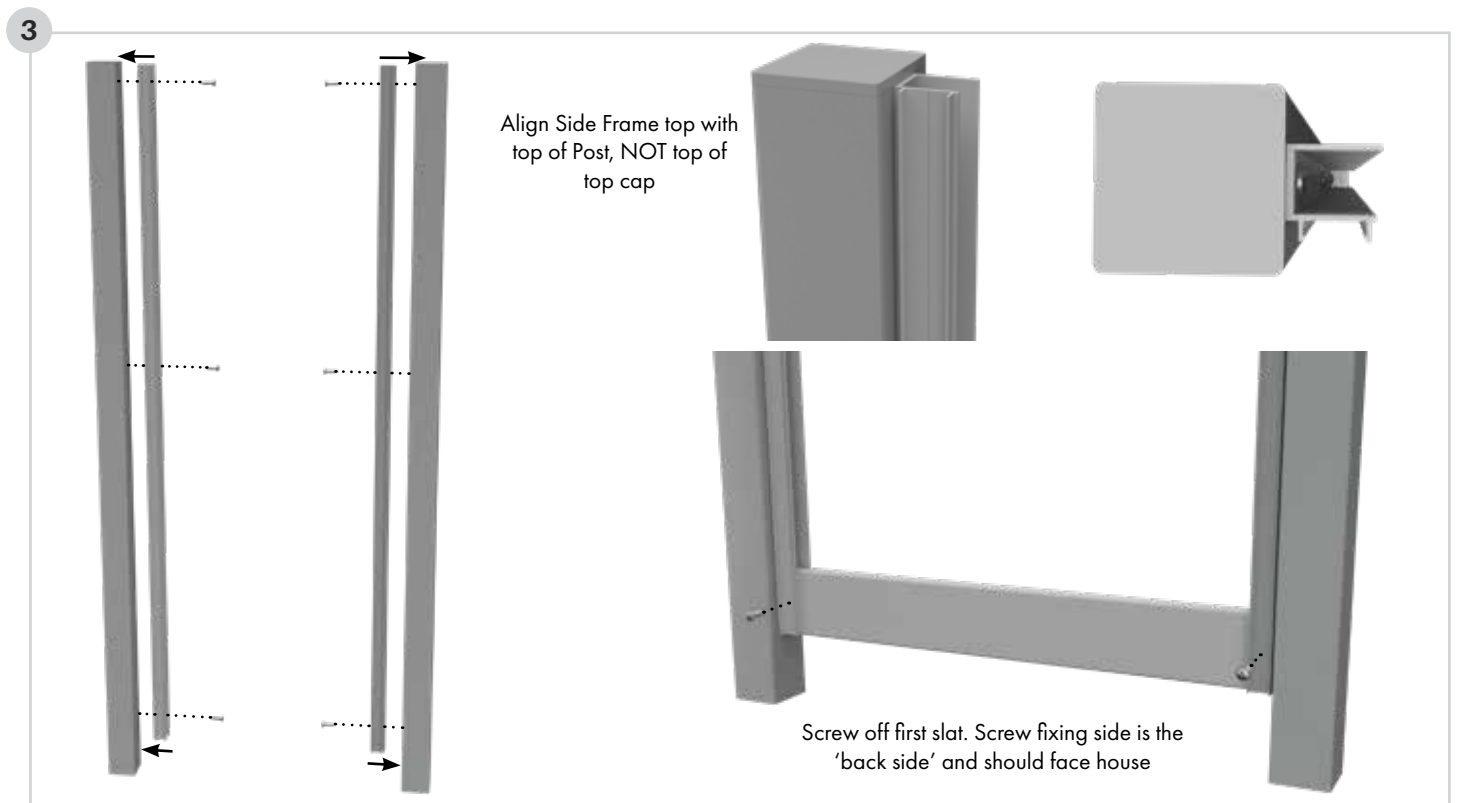

Attach side frame inline with the top of the post (not top of post cap). Fix off sideways through side frame into post at 3 places – top, middle and bottom of side frame. Install the bottom slat ensuring level and screw fix both sides using 10Gx18mm screws.

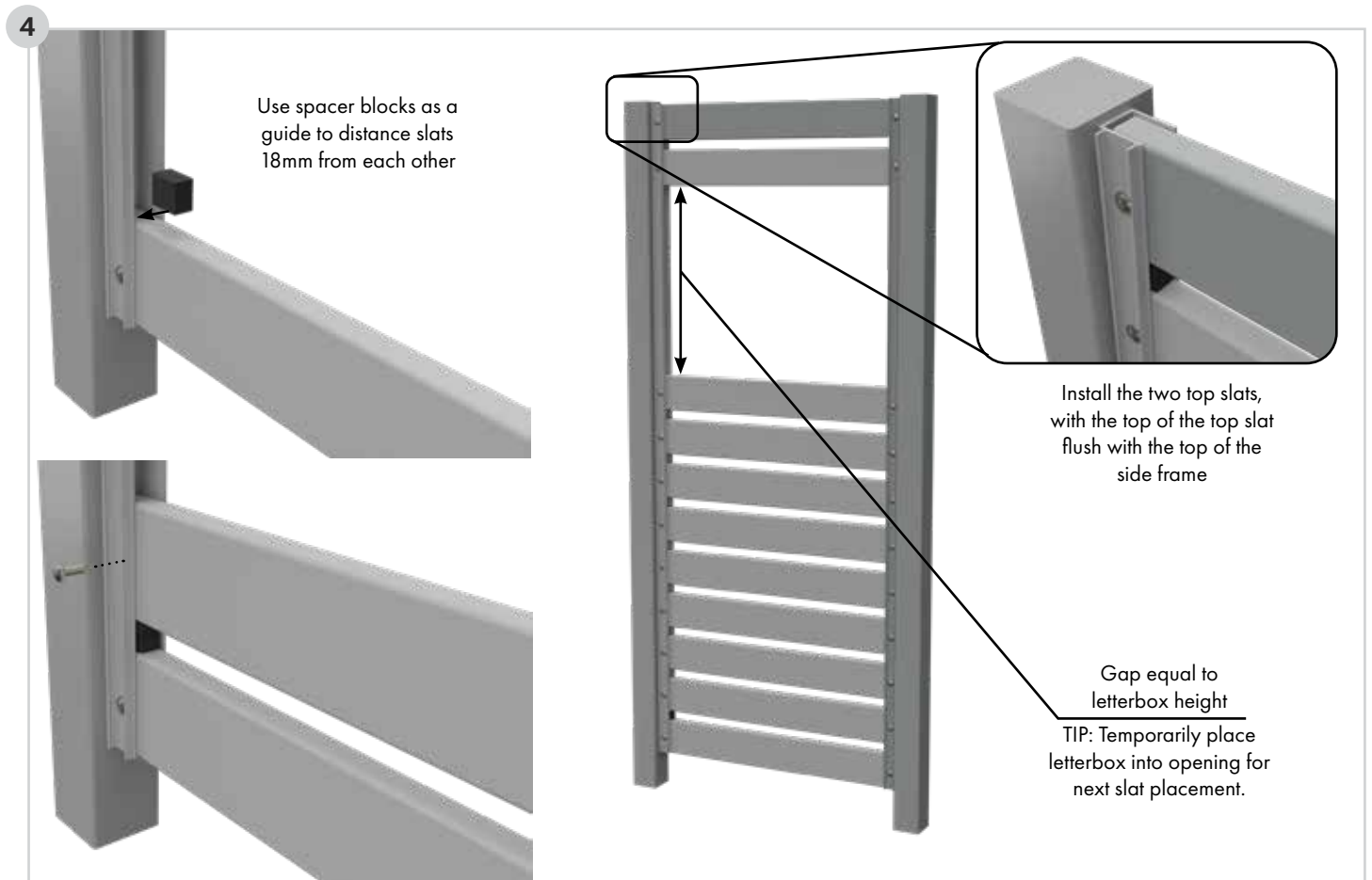

Using 18mm spacer (2x9mm spacers taped together from Quickscreen Kit), install each slat one at a time for the first 9 slats. Use 1 x 10Gx18mm screw each side of slat. Using the letterbox to temporarily set the void, install the two top slats with an 18mm space between them and the top slat flush against the top of the side frame. Spacer blocks may be removed once slats are screw-fixed to position.

POSTA SLAT LETTERBOX INSTALL GUIDE

5

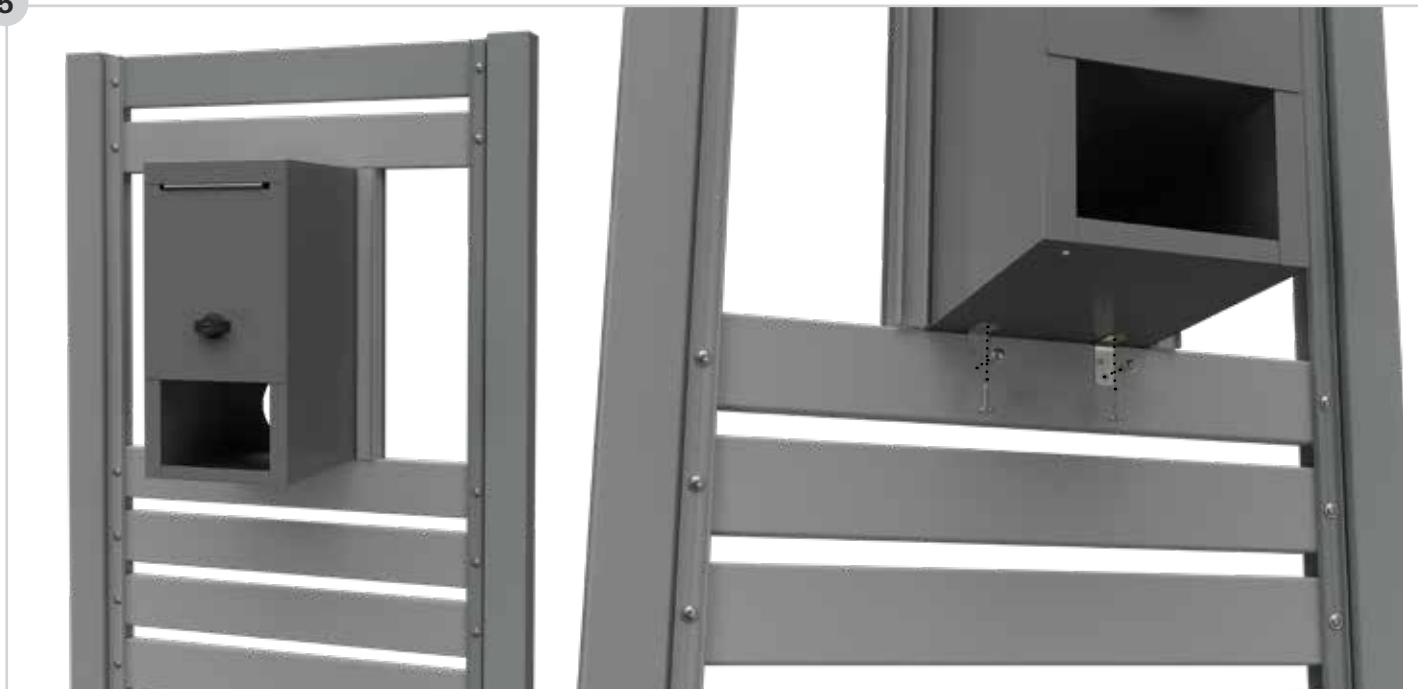

Resting the letterbox in the slat opening and centring the letterbox equally between the two posts, screw the two supplied angle brackets to the underneath of the letterbox body using the 10Gx18mm screws, ensuring the face of the letterbox is firm against the slat at the front.

NOTE: Do not cover drain holes in the letterbox body

6



Loosely fit the next 3 short slats each side of the letterbox, then screw-fix ensuring an 18mm gap between each.

TIP: to fit into void gap, tilt the slats at an angle and then straighten out to level.

TYPICAL CONFIGURATION

POSTA SLAT LETTERBOX INSTALL GUIDE

7

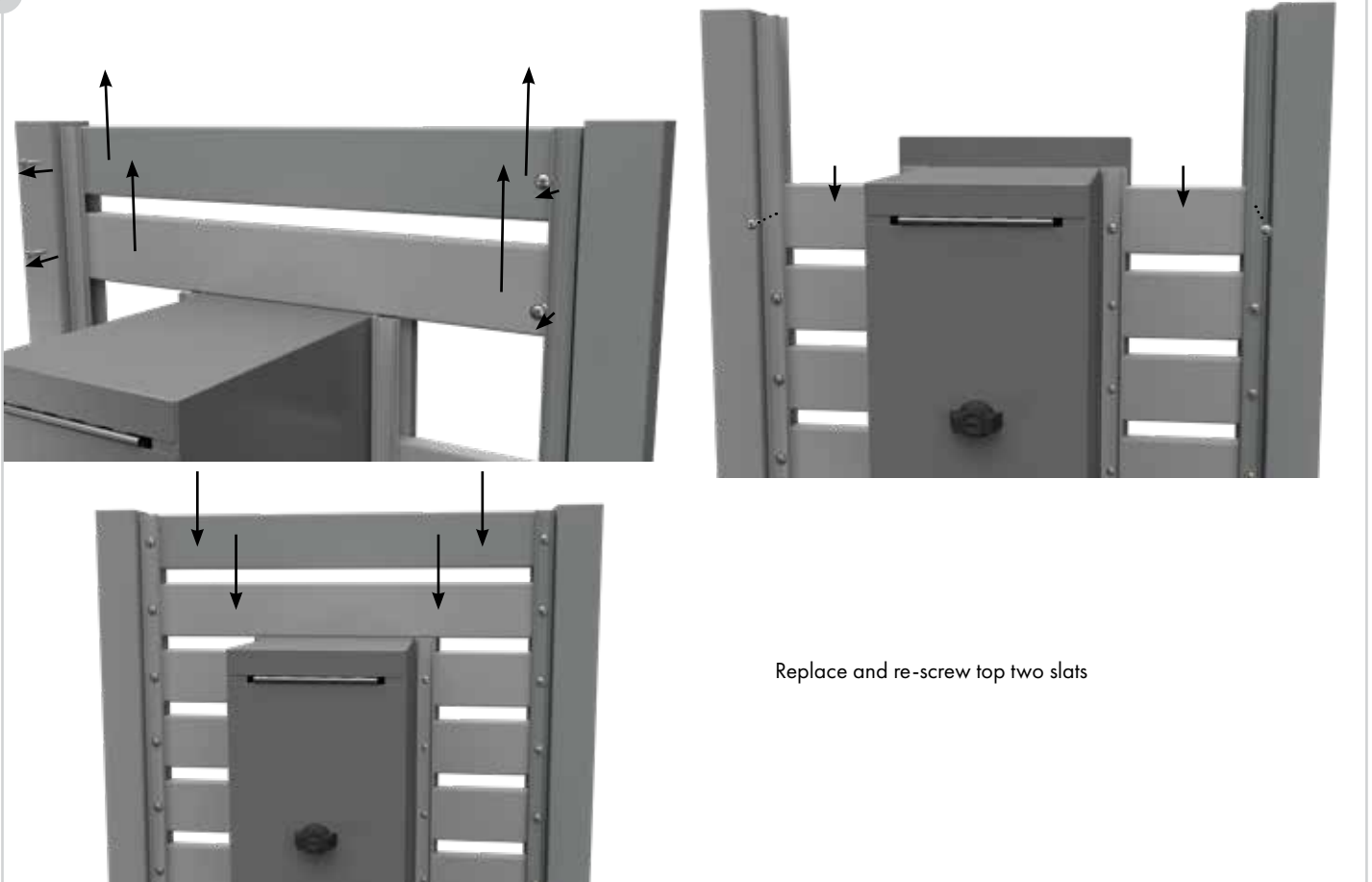

Replace and re-screw top two slats

Unscrew and remove the top two slats temporarily and position the final two short slats each side of the letterbox. Replace the top two full slats and re-screw. Screw-fix the final short slats with an 18mm space.

8

Snap on side frame covers

TIP: Engage shorter leg of snap-on cover first.

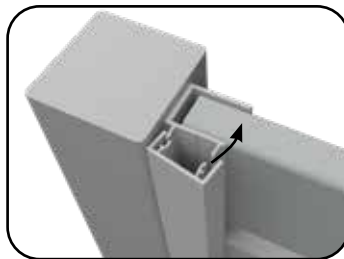

TIP: Use a mallet with a wood block to tap on side frames

Snap on side frame covers for side frames attached to letterbox

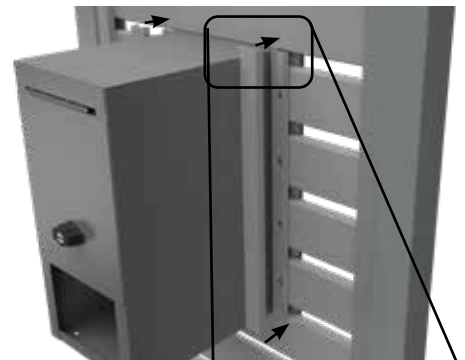

Ensure covers protrude 10mm higher than the top of the letterbox body



Fit concealing fixing covers to each post side frame to hide slat screws.

TIP: Engage shorter leg of snap-on cover first. At this point the snap-on cover will be sitting off the frame on an angle, the longer leg must be at open side of frame.

Starting from one side and working your way along, use a wood block and a hammer/mallet to tap the longer leg in place. A short, sharp tap may be required to engage the long leg.

Fit concealing fixing covers to each side frame attached to the letterbox body, ensuring the covers protrude 10mm higher than the top of the letterbox body.

TYPICAL CONFIGURATION
POSTA SLAT LETTERBOX INSTALL GUIDE

9

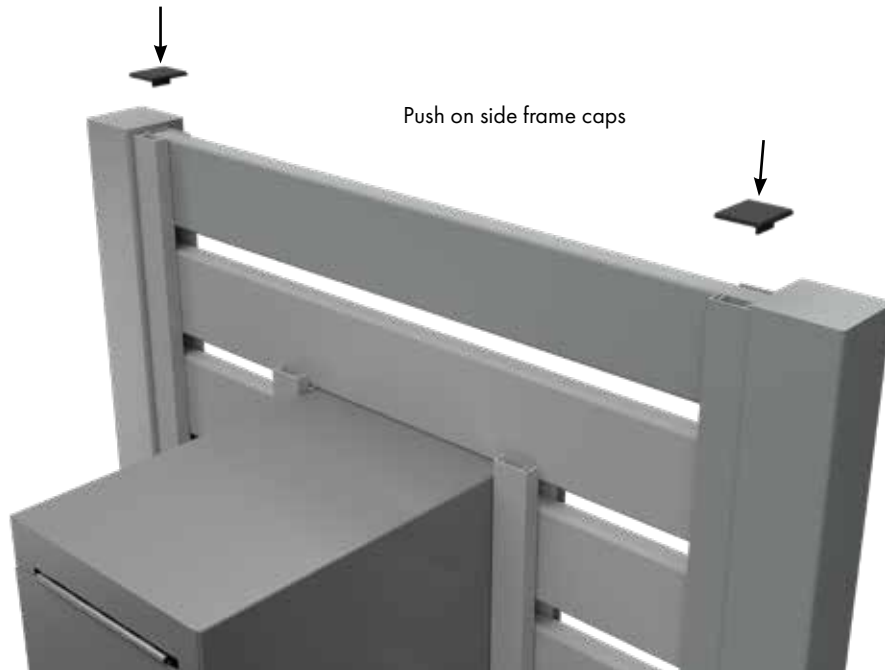

Fit 2x side frame caps.

COMPLETED







POSTA CHARACTERS

POSTA Letters & Characters

Order Code: See table on page 165
Each number/letter sold separately

Finishes –



1 2 3 4 5 6 7 8 9 0 / A B C
1 2 3 4 5 6 7 8 9 0 / A B C

5 FINISHES AVAILABLE

- 1 50mm – Black powder coat with stick on 3M adhesive
- 2 50mm – SS316 Satin with stick on 3M adhesive
- 3 120mm – Black powder coat with stick on 3M adhesive
- 4 120mm – SS316 Satin with stick on 3M adhesive
- 5 120mm – SS316 Satin with stud fixing**

TECH SPECS

- Numbers & letters available in 50mm or 120mm high
- Available in stainless steel 316 or black powder coated aluminium
- Simple solution – simply stick onto letterbox, post or wall with 3M adhesive or use 'stud' option (SS316 POSTA only) with rods
- Stylish modern font

**EASY STUD INSTALLATION (SS316 POSTA ONLY)

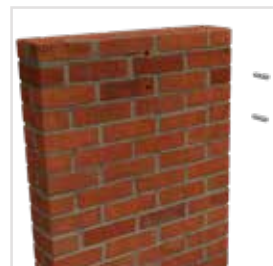

Timber frame

- 1 Mark holes using studs as a guide. Drill two 4mm holes. (Drill two 6mm holes for flush mount).
- 2 Attach character using threaded rods, washers and nuts provided.

Brick

- 1 Mark holes using studs as a guide.
- 2 Drill two 5.5mm holes, 40mm deep and insert wall plugs.
- 3 Screw threaded pins to character and push character into wall.

CHARACTER ORDER CODES

1
50mm
A

Order Code	Description
POSTA 50MM HIGH – ALUMINIUM BLACK Powder coat 3mm thick with 3M adhesive tape	
POSTA-BLK-H050-0	Number "0"
POSTA-BLK-H050-1	Number "1"
POSTA-BLK-H050-2	Number "2"
POSTA-BLK-H050-3	Number "3"
POSTA-BLK-H050-4	Number "4"
POSTA-BLK-H050-5	Number "5"
POSTA-BLK-H050-6	Number "6"
POSTA-BLK-H050-7	Number "7"
POSTA-BLK-H050-8	Number "8"
POSTA-BLK-H050-9	Number "9"
POSTA-BLK-H050-/ Character "/"	Character "/"
POSTA-BLK-H050-A	Letter "A"
POSTA-BLK-H050-B	Letter "B"
POSTA-BLK-H050-C	Letter "C"

2
50mm
A

Order Code	Description
POSTA 50MM HIGH – SS316 SATIN 1.5mm thick with 3M adhesive tape	
POSTA-SS-H050-0	Number "0"
POSTA-SS-H050-1	Number "1"
POSTA-SS-H050-2	Number "2"
POSTA-SS-H050-3	Number "3"
POSTA-SS-H050-4	Number "4"
POSTA-SS-H050-5	Number "5"
POSTA-SS-H050-6	Number "6"
POSTA-SS-H050-7	Number "7"
POSTA-SS-H050-8	Number "8"
POSTA-SS-H050-9	Number "9"
POSTA-SS-H050-/ Character "/"	Character "/"
POSTA-SS-H050-A	Letter "A"
POSTA-SS-H050-B	Letter "B"
POSTA-SS-H050-C	Letter "C"

3
120mm
A

Order Code	Description
POSTA 120MM HIGH – ALUMINIUM BLACK Powder coat 3mm thick with 3M adhesive tape	
POSTA-BLK-H120-0	Number "0"
POSTA-BLK-H120-1	Number "1"
POSTA-BLK-H120-2	Number "2"
POSTA-BLK-H120-3	Number "3"
POSTA-BLK-H120-4	Number "4"
POSTA-BLK-H120-5	Number "5"
POSTA-BLK-H120-6	Number "6"
POSTA-BLK-H120-7	Number "7"
POSTA-BLK-H120-8	Number "8"
POSTA-BLK-H120-9	Number "9"
POSTA-BLK-H120-/ Character "/"	Character "/"
POSTA-BLK-H120-A	Letter "A"
POSTA-BLK-H120-B	Letter "B"
POSTA-BLK-H120-C	Letter "C"

4
120mm
A

Order Code	Description
POSTA 120MM HIGH – SS316 SATIN 1.5mm thick with 3M adhesive tape	
POSTA-SS-H120-0	Number "0"
POSTA-SS-H120-1	Number "1"
POSTA-SS-H120-2	Number "2"
POSTA-SS-H120-3	Number "3"
POSTA-SS-H120-4	Number "4"
POSTA-SS-H120-5	Number "5"
POSTA-SS-H120-6	Number "6"
POSTA-SS-H120-7	Number "7"
POSTA-SS-H120-8	Number "8"
POSTA-SS-H120-9	Number "9"
POSTA-SS-H120-/ Character "/"	Character "/"
POSTA-SS-H120-A	Letter "A"
POSTA-SS-H120-B	Letter "B"
POSTA-SS-H120-C	Letter "C"

5



Floating/
3D effect sits
off 8mm

Scan QR code for
detailed install
instructions
PWD - Posta1



Order Code	Description
POSTA – 120MM High WITH STUD MOUNT – SS316 SATIN 1.5mm thick with 2 x M4 SS304 threaded rod + nuts/ washers and 2 x M4 pointed SS304 threaded rod	
POSTA-STUD-H120-0	Number "0"
POSTA-STUD-H120-1	Number "1"
POSTA-STUD-H120-2	Number "2"
POSTA-STUD-H120-3	Number "3"
POSTA-STUD-H120-4	Number "4"
POSTA-STUD-H120-5	Number "5"
POSTA-STUD-H120-6	Number "6"
POSTA-STUD-H120-7	Number "7"
POSTA-STUD-H120-8	Number "8"
POSTA-STUD-H120-9	Number "9"
POSTA-STUD-H120-/ Character "/"	Character "/"
POSTA-STUD-H120-A	Letter "A"
POSTA-STUD-H120-B	Letter "B"
POSTA-STUD-H120-C	Letter "C"



Errors and omissions excepted. Measurements and drawings are provided as a guide only and should not be relied upon solely for installation purposes.

Product codes, products and prices may change at GO/AO's discretion as systems are constantly reviewed and updated. Please contact GO/AO if you require clarification of product codes, pricing or product stocking.

Due to each installation situation being different, it is the installer's responsibility to seek engineering compliance and/or certification should it be required as part of a project, regulatory or statutory requirement.

As each installation site is different, it is the installer's responsibility to consider the impact of wind loads on the design of a fence. Please consult your engineer for site specific matters relating to wind loads.

Colours displayed in PDF's or printed documents are indicative only and should not be relied on as a true representation of actual powder coat colour. All products should adhere to a suitable care and maintenance schedule.

©Copyright 2022. This catalogue is the copyright of GO/AO and cannot be reproduced, copied or replicated without the prior written consent of GO/AO. Such consent applies to images as well as text.

GO/AO Xpress Plus & Alumawood Screening Systems V3